



## *Owner's Manual*

---

# **FLETCHER 1100 PROFESSIONAL OVAL AND CIRCLE CUTTING SYSTEM**

Set Up, Operation & Maintenance

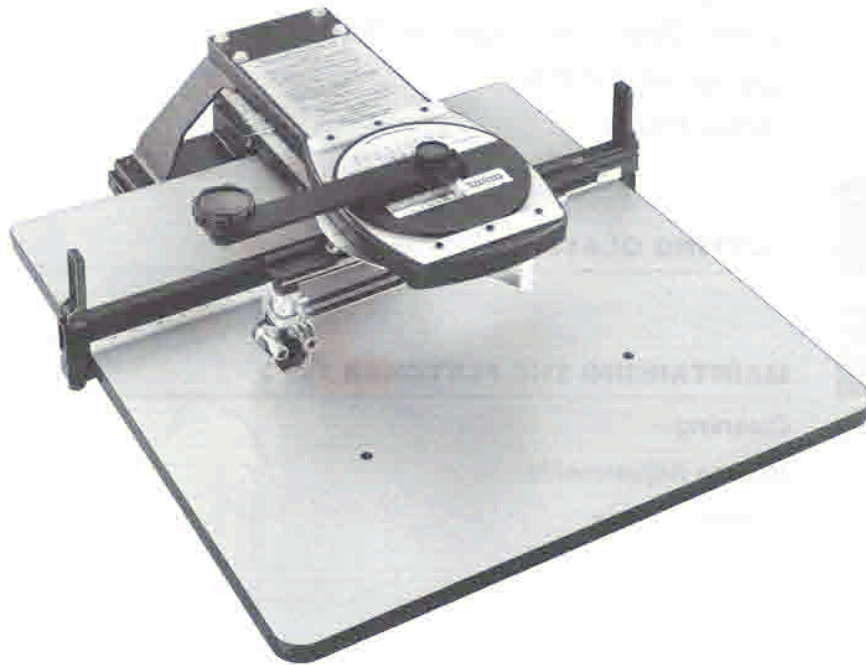

### ***THE FLETCHER-TERRY COMPANY***

65 Spring Lane • Farmington, Connecticut, USA 06032-3311  
(860) 677-7331 • (800) 843-3826 • Telex 966-479 • Fax (860) 676-8858

**1****ABOUT THE FLETCHER 1100** **3**

---

**2****SETTING UP** **6**

---

Unpacking Your Machine **6**Using Mat Blades **6****3****CUTTING MATS** **8**

---

Cutting Ovals **8****Cutting Circles** **11**

---

Cutting V-Grooves **12**Cutting Small Ovals and Circles **12**Cutting Close to the Top of the Mat **13**Cutting Multiple Mats **14**Special Effects **14****4****CUTTING GLASS** **16**

---

**5****MAINTAINING THE FLETCHER 1100** **17**

---

Cleaning **17**Making Adjustments **17**Assembly View **20**Parts List **21**Troubleshooting **22**

Congratulations! The Fletcher 1100™ Professional Oval and Circle Mat Cutting System uses the unique proven features of the Fletcher 1000 and adds many new features to make it the most versatile oval and circle cutter available. The result is perfect ovals that do not lean, are not misshapen at sharp curves, and show a smooth transition between the starting and stopping points.

With the Fletcher 1100, your profitability is limited only by your imagination.

The Fletcher 1100 allows you to cut:

- True, accurate ovals and circles
- Ovals and circles from 1" [25mm] to 24" [600mm] wide
- 1/2" [12mm] from the top of the mat
- Perfect V-grooves without attachments
- Ovals and circles from the front or back of the mat
- Ovals and circles in glass
- Accurate multiple mats, multiple openings and inlays that fit perfectly

The Fletcher 1100 is available with either inch or metric scales. Throughout this manual, when dimensions are used to describe an action or measurement, metric dimensions are given in brackets [mm]. The metric dimension may not be the exact equivalent, but it will be a suitable working dimension.

You should read through this Owner's Manual before you begin cutting mats with the Fletcher 1100.

**Note:** All instructions in this manual assume that you are facing the front of the machine and that the **Handle** is pointing to the left (at the 9 o'clock position).

If you have questions about using the Fletcher 1100, contact your Fletcher-Terry distributor or The Fletcher-Terry Company customer service department (toll-free 1-800-THE-FTCO (843-3826) in the U.S.; outside of the U.S. call 860-677-7331; TELEX 966-479; FAX 860-676-8858).

The Fletcher-Terry Company warrants the Fletcher 1100™ Professional Oval and Circle Cutting System (patents 5,033,346, 5,014,584 and 5,099,727) to be free from defects in parts and workmanship for two years. The Fletcher-Terry Company warrants that it will repair or replace any such defective machine or replace parts, providing the machine has been under normal use and service. Authorization for the return must come from The Fletcher-Terry Company in writing. Proof of purchase must be submitted to validate warranty coverage.

This warranty is in lieu of all other agreements and warranties expressed or implied. The Fletcher-Terry Company neither assumes nor authorizes any other person or representative to assume for it any other liability in connection with the Fletcher 1100™ Professional Oval and Circle Cutting System. The Fletcher-Terry Company shall not be liable for any damages or losses, incidental or consequential, direct or indirect, arising out of use of this product.

This Warranty is valid after you return the warranty card (in the parts bag) to The Fletcher-Terry Company.

# The Fletcher 1100 Professional Oval and Circle Cutting System

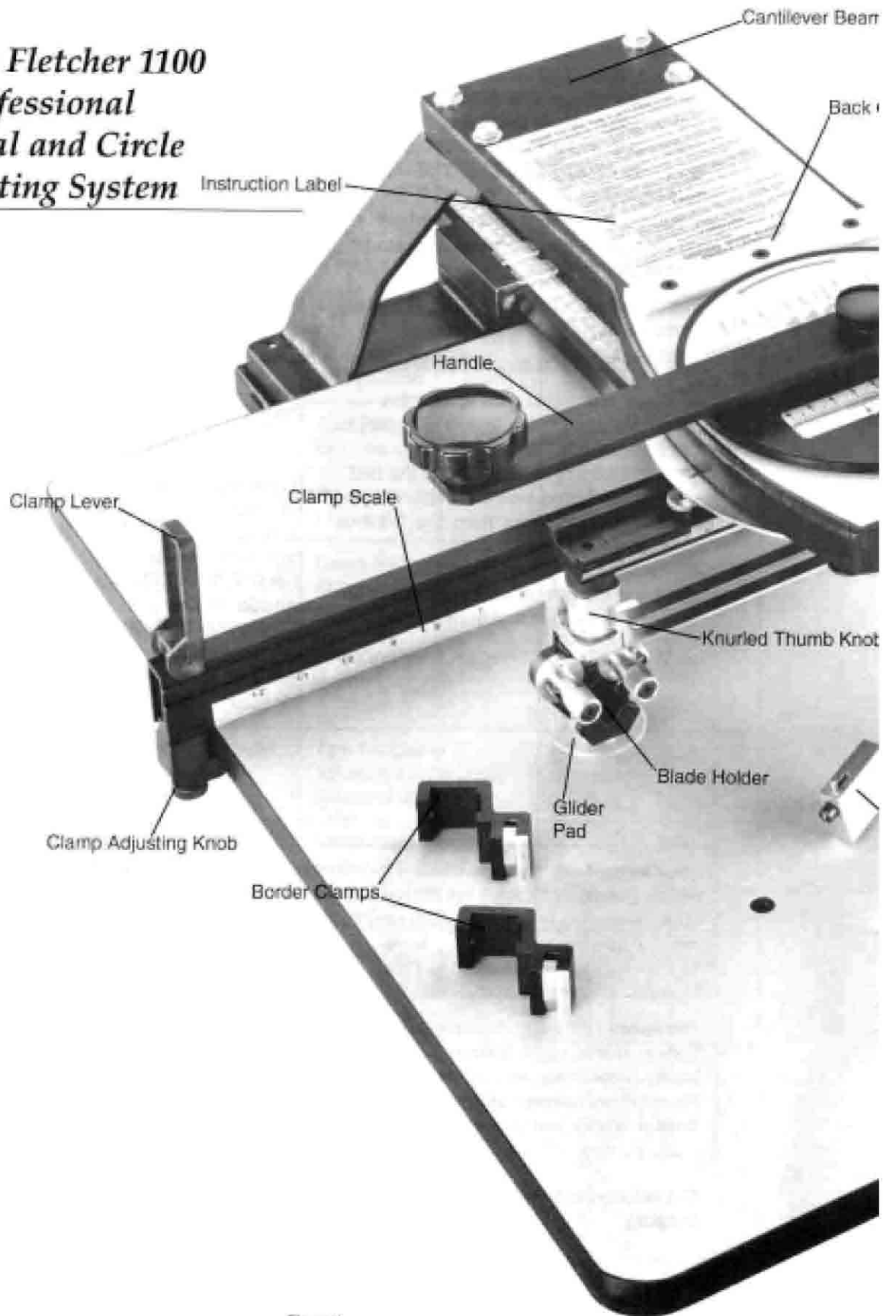
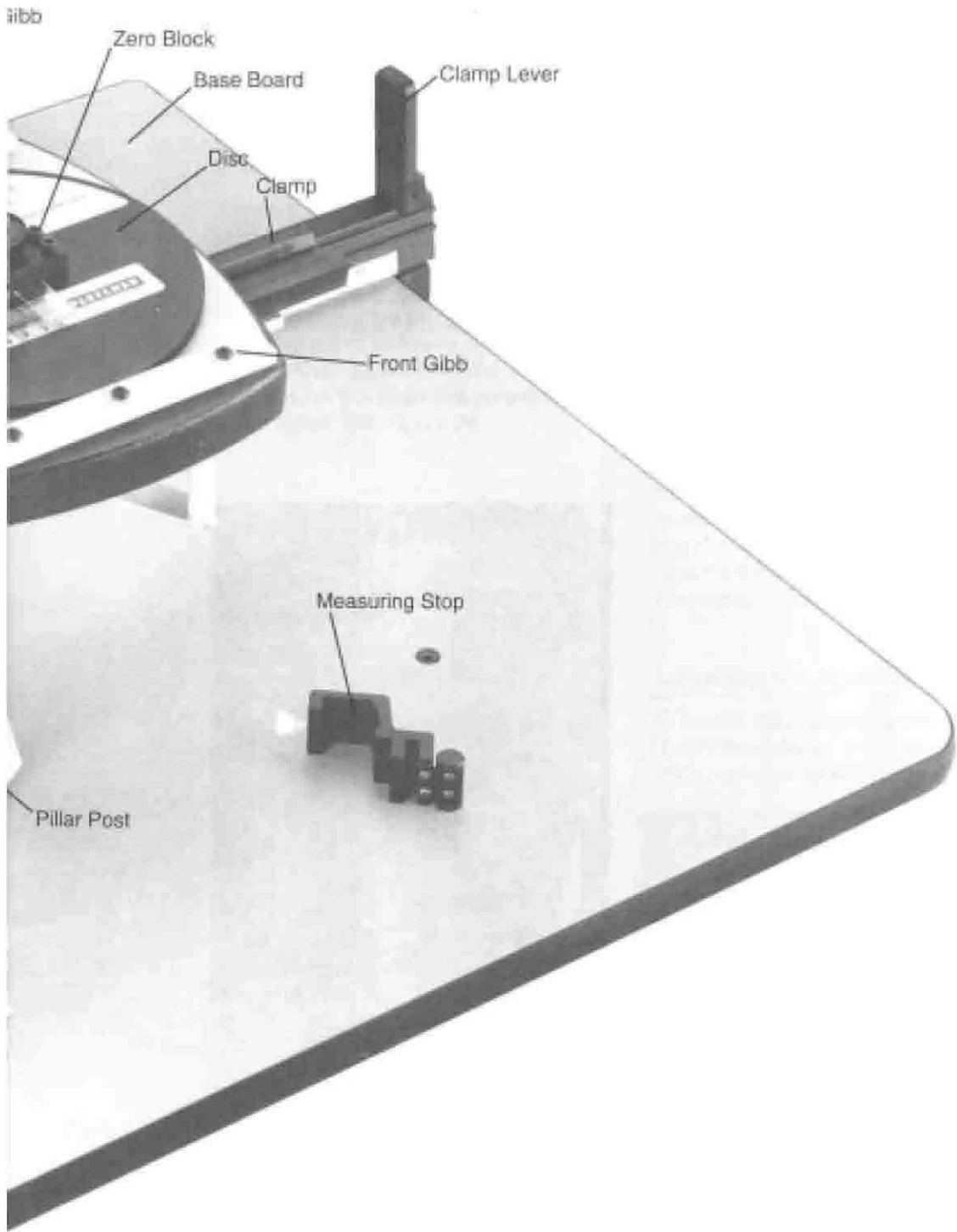

Figure 1



## Unpacking Your Machine

If the shipping carton is damaged when you receive your machine, please call your shipper and file a claim.

Remove the Fletcher 1100 from its shipping carton. The machine comes completely assembled. You should also have these items in the parts bag (see Figure 2):

- 10 cutting blades
- short **Lower Yellow Beam**
- **Pillar Post**
- carbide wheel unit (03-130)
- 2 **Border Clamps**
- **Measuring Stop**
- 4 hex wrenches
- warranty card
- Owner's Manual



Figure 2

Place the machine on a flat table surface with at least 11" (280mm) clearance behind the machine. The machine is easiest to work with if it is at least waist-high.

## Using Mat Blades

The Fletcher 1100 uses #3-type blades, which are available in bulk packs of 100 (05-007). A sharp blade is essential to producing quality mats, so change your blade as soon as you feel it is not cutting cleanly.

### Inserting Blades

1. Unscrew and remove the **Blade Holder Screw**. Pull the **Blade Holder** straight out and off the machine.

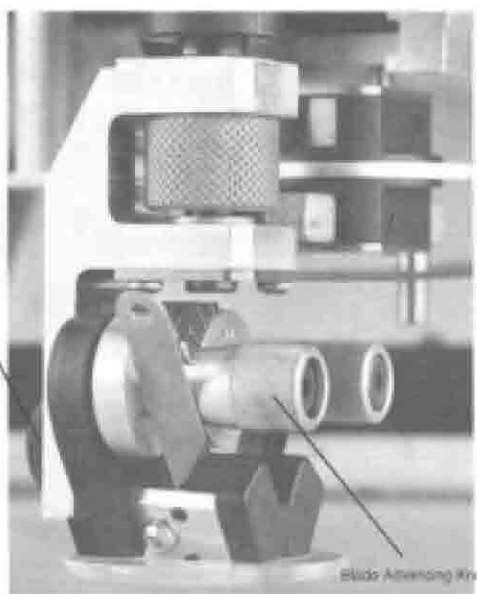

Figure 3

2. If there is a blade in the slot, remove it. Hold the **Blade Holder** in one hand, pull the left (or right) **Blade Advancing Knob** toward you and rotate it clockwise (or counterclockwise) to slip the blade pin out of the blade. Pull it out and discard it.
3. Slide a new blade in the slot, making sure that the sharp edge will face the front of the machine. See Figure 3.

4. Rotate the **Blade Advancing Knob** back into position; its pin will slip into the hole in the new blade. Rotate the **Blade Advancing Knob** to zero.
5. Repeat steps 2 through 4 to insert the other blade.
6. Replace the **Blade Holder** and tighten the **Blade Holder Screw**.

*Note:* Do not advance both blades at the same time. This will damage the blades.

**CAUTION**

Use extreme care when handling blades.  
They are Super Keen®.

This section describes basic techniques of cutting:

- ovals
- circles
- v-grooves
- small ovals and circles
- cut-outs near the top edge of the mat
- multiple mats
- special effects, such as multiple openings, inlays and overlays

Always use a slip sheet when you are cutting mats to guarantee that you get a crisp, sharp bevel on your mat. Make a slip sheet by cutting a piece of mat board about 24" [600mm] square. Lay it on the **Base Board**.

The Fletcher 1100 cuts through mat and foam boards up to 1/4" [6mm] thick.

*Note:* Make sure the **Handle** is in the 9 o'clock position, pointing to the left, when you are setting measurements for mat cutting.

## Cutting Ovals

To follow these instructions, prepare a mat board 16" wide by 20" high [400mm x 508mm]. You will be cutting a 5" x 8" [130mm x 200mm] oval in the center of the mat.

To cut ovals, you must know what your *off-set* is: The off-set is the difference between the length and width of the oval. In this example, the off-set is 3" [70mm]—the difference between 5" [130mm] and 8" [200mm]. (The maximum off-set is 6" [152mm].) See Figure 4.

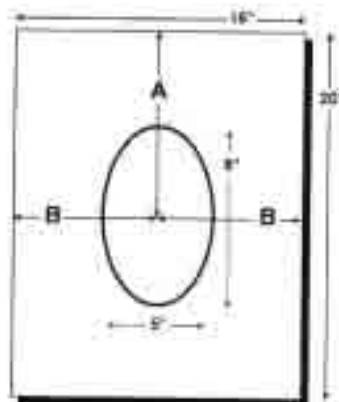

Figure 4

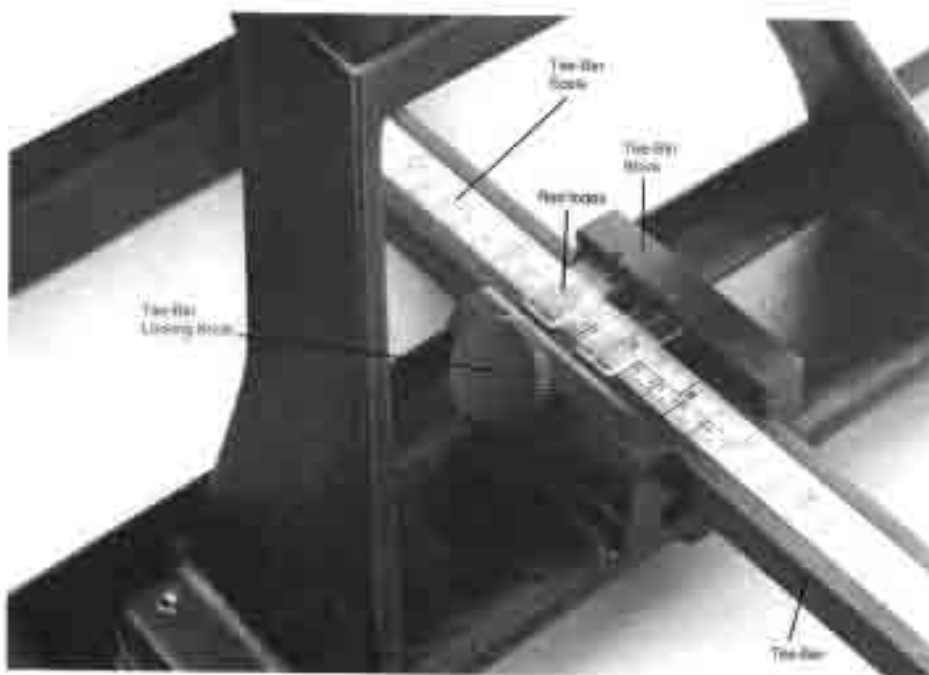

Figure 5



### Positioning the mat board

1. To cut a mat on the Fletcher 1100, you must know where the center of your cut-out will be from the top edge (A) and side edges (B) of the mat. See Figure 4. Locate the center of the cut-out from the top edge of the mat (A) by using the *red* index line on the **Tee-Bar Scale**. In this example, the cut-out will be in the center of the mat board (10" [254mm] from the top of the mat), so use 10" [254mm] as your measurement. Loosen the **Tee-Bar Locking Knob** on the **Tee-Bar Block** and slide the **Tee-Bar** so that the red index line is positioned at 10" [254mm] on the **Tee-Bar Scale**. Tighten the **Locking Knob**. See Figure 5.
2. Push the slip sheet and the top edge of the mat under the **Clamp Scale**. (It is easier to push the mat under the **Clamp** first, then the slip sheet.) Since the oval will be centered, set B on the left or right side of the **Clamp Scale**. (For the 16" [400mm]-wide mat, the reading (B) will be 8" [200mm].) Push the left and right **Clamp Levers** down to lock the mat and slip sheet securely under the **Clamp**. If the mat is not held tightly, turn the left and right **Clamp Adjusting Knobs** at each end of the **Clamp**. See Figure 6.

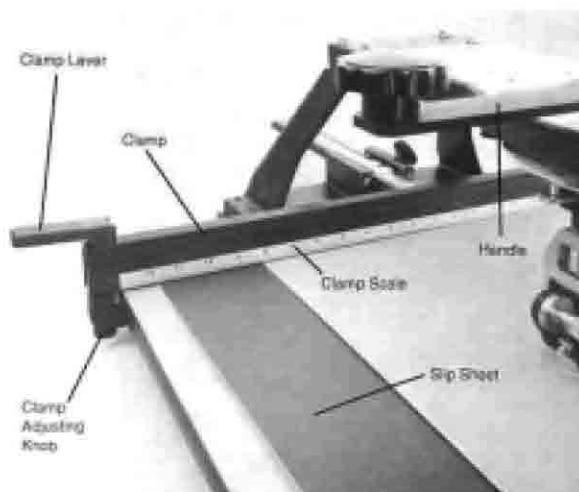

Figure 6

### Setting the cutting measurements

3. With the **Handle** in the 9 o'clock position, set the **Cutter Bar Scale** to the width of the oval you wish to cut (in this case, 5" [130mm]). Loosen the **Cutter Bar Locking Knob** (to the rear) and slide the **Cutter Bar** so that the oval's width (5" [130mm]) shows to the left of the **Cutter Bar Indicator**. Tighten the **Cutter Bar Locking Knob**. See Figure 7.



Figure 7

4. Set the off-set on the **Disc Scale** by slightly loosening the **Handle Locking Knob** on top of the **Disc** and sliding the **Disc** left or right until the **Disc Scale** reads 3" [70mm]. Tighten the **Handle Locking Knob**. See Figure 8.

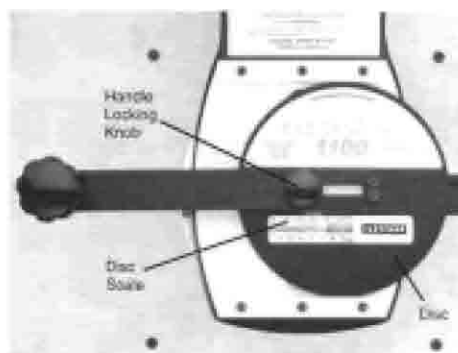

Figure 8

- Set the off-set on the **Upper Yellow Beam** by loosening the **Slide Knob** (to the front) and sliding the **Upper Yellow Beam** until it reads 3" [70mm] to the right of the hub. Tighten the **Slide Knob**. See Figure 9.
- Set the off-set on the **Lower Yellow Beam** by loosening its **Locking Knob** (to the rear, under the **Boomerang**) and sliding the **Lower Yellow Beam** until it reads 3" [70mm] to the right of the hub. Tighten the **Locking Knob**. See Figure 9.

**Important:** When the off-set is 2" [50mm] or less, set both **Yellow Beams** to read 6" [150mm].

- Make sure the **Handle** will rotate freely by turning it counterclockwise. If the off-sets are not set precisely, the **Handle** may bind. Check and adjust the settings before proceeding.

**Important:** When your off-set is less than 4", the **Lower Yellow Beam** extends beyond the left side of the hub and may touch the **Knurled Thumb Knob** during rotation. When this happens, use the short **Lower Yellow Beam** included in your parts bag. Loosen the **Lower Yellow Beam Locking Knob**, slide the **Lower Yellow Beam** to the right until you can lift it out.

Replace it with the short **Lower Yellow Beam** and tighten its **Locking Knob**.

### Cutting the mat

- Start with the **Handle** at the 9 o'clock position. Rotate the **Knurled Thumb Knob** to lower the **Blade Holder** so that the **Glider Pad** lightly touches the mat. The clear plastic disk contacts the mat and provides a smooth friction-free pad. See Figure 10.
- By turning the left **Blade Advancing Knob**, insert the left blade into the mat until it just starts to cut (about setting 2) while you slowly rotate the **Handle** counterclockwise. Rotate the **Handle** one complete rotation until the blade is 1" beyond its original insertion point. Again, while rotating the **Handle**, turn the left **Blade Advancing Knob** to insert the blade deeper into the mat (about setting 3). Make one complete rotation. (Two rotations will usually cut through the mat; the second cut should slightly cut into the slip sheet.) See Figure 10.
- Turn the **Blade Advancing Knob** back to zero to retract the blade. Raise the **Blade Holder**, raise the **Clamp Levers**, and remove the mat and cut-out.

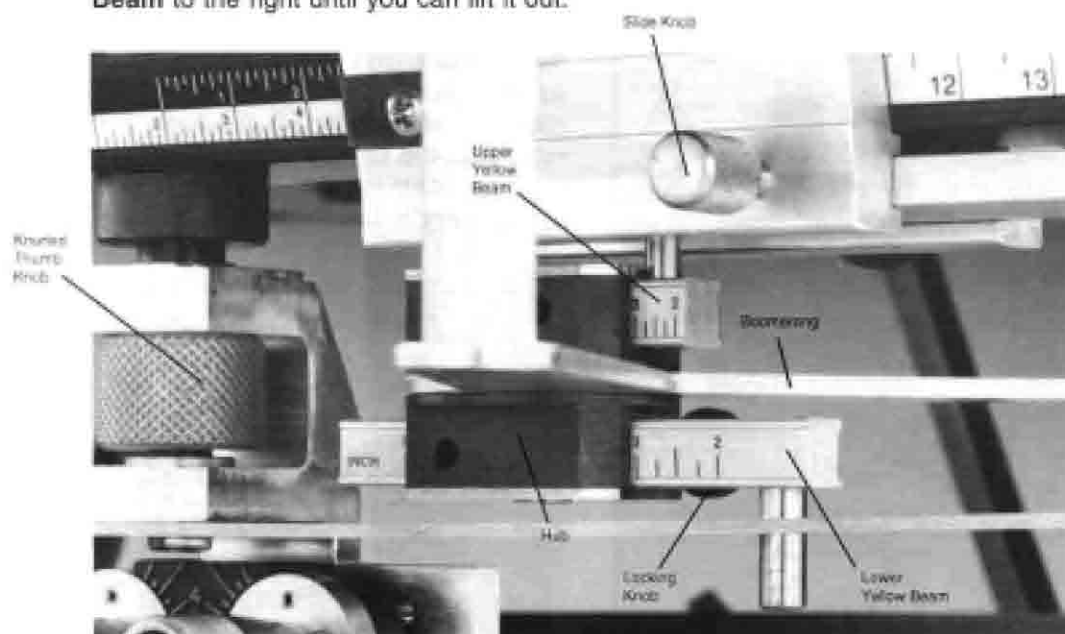

Figure 9

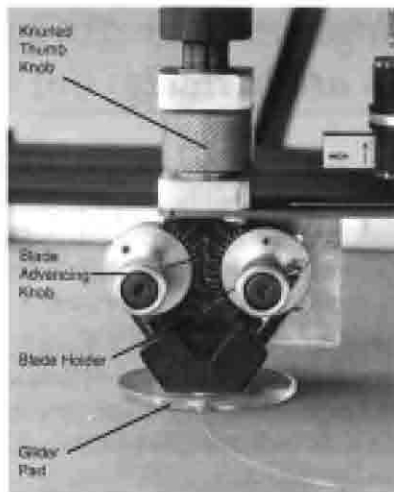

Figure 10

*Note:* If you lower the blade while you rotate the **Handle**, your mat will be free of any discernable “glitches” where you begin the cut.

*Note:* The numbers on the **Blade Holder** are simply guides. The thickness of the mat determines how far the blade should be extended to cut through. Cutting into the **Base Board** will ruin your blade.

*Note:* If the mat is fabric-coated, or you do not want to set the **Glider Pad** on the front of the mat, you can cut from the back of the mat. Cut the mat facing down with the *right* blade. All other steps and measurements are the same.

## Cutting Circles

When cutting a circle in a mat, the off-set (difference between length and width) is zero. The off-sets on the **Yellow Beam Scales** do not need to be adjusted.

1. Set the **Cutter Bar** to the desired diameter of the circle. Set the **Disc Scale** to zero (since your off-set is zero). (The **Handle** will be touching the **Zero Block**. See Figure 11.)
2. Repeat steps 8, 9 and 10 in “Cutting Ovals” to cut the mat.

*Note:* If you are cutting a small circle (less than 2-1/2" [64mm]), extend the **Lower Yellow Beam** to the right to make sure it does not touch the **Blade Holder**.

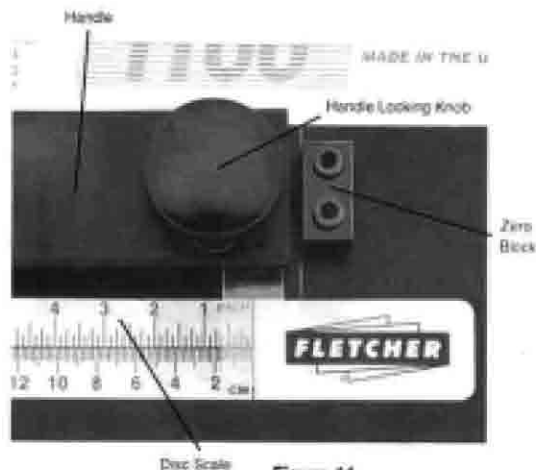

Figure 11

## Cutting V-Grooves

Leave the mat clamped in the same position to cut a v-groove. You will make a second cut outside the circle or oval you already cut in the mat.

1. Set the **Cutter Bar** to a larger width than the oval or circle cut. For example, if you want the v-groove to be 1/2" [12mm] outside the cut, set the **Cutter Bar** 1" [24mm] greater than the width of the oval or circle cut. (In our example, the 5" [154mm] oval measurement would be changed to 6" [160mm].) Do not change the off-set positions on the **Disc** or the **Yellow Beams**.
2. Start with the **Handle** at the 9 o'clock position. Rotate the **Knurled Thumb Knob** to lower the **Blade Holder** so that the **Glider Pad** lightly touches the mat. By turning the left **Blade Advancing Knob**, insert the left blade into the mat until it just starts to cut (about setting 2) while you slowly rotate the **Handle** counterclockwise. Rotate the **Handle** one complete rotation until the blade is 1" beyond its original insertion point. Retract the left blade.
3. Reposition the **Handle** at the 9 o'clock position. Repeat step 2, but lower the right blade instead of the left. After one revolution, retract the right blade.
4. Raise the **Blade Holder**, unclamp the mat, and remove the cut-out material. See Figure 12.

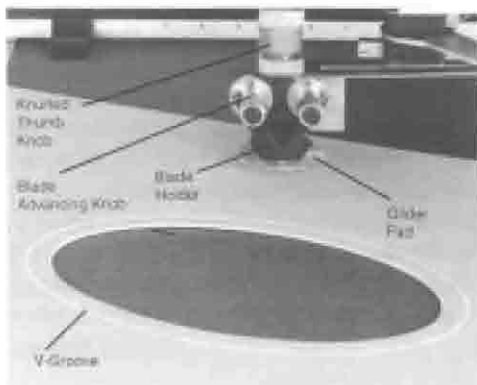

Figure 12

## Cutting Small Ovals and Circles

The Fletcher 1100 can cut ovals and circles as small as 1" [25mm] wide. For ovals and circles less than 2-1/2" [64mm] wide, you will have to make the following adjustments.

1. Unscrew the **Blade Holder Screw**, remove the **Blade Holder** and place it in the right mounting hole. Tighten the **Blade Holder Screw**. See Figure 13.

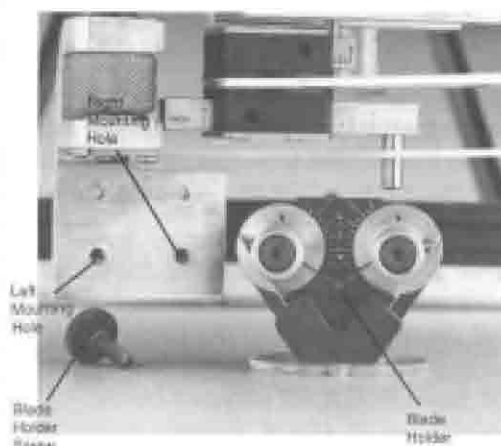

Figure 13

2. Set the **Cutter Bar** for the width of the oval or circle using the **black Cutter Bar Scale**. (This scale only reads up to 3" [76mm].) See Figure 14.
3. Set the off-sets as you would normally.
4. Follow steps 8, 9 and 10 in "Cutting Ovals" (page 10).

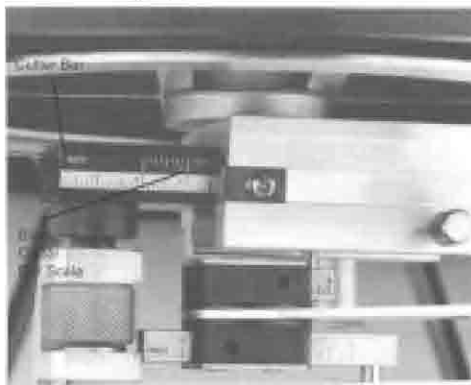

Figure 14

## Cutting Close to the Top of the Mat

Normally, if the top of a cut is closer than 1-1/2" [38mm] to the top of the mat, the **Blade Holder** will touch the **Clamp Scale** during rotation. Use the two **Border Clamps**, included in your parts bag, to cut an opening as close as 1/2" [12mm] from the edge of the mat.

1. Indicate the center of the cut-out by setting the **Tee-Bar Scale** using the *black index line* (instead of the red index line). See Figure 15.

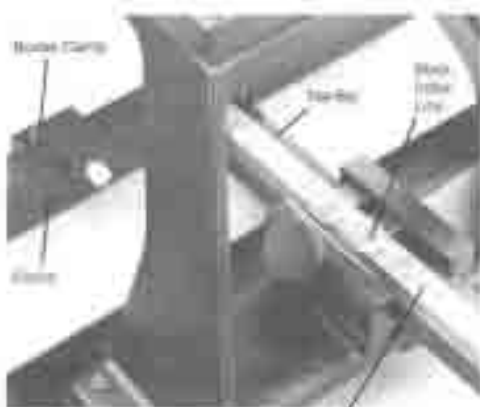

Figure 15

2. Attach the **Border Clamps** to the **Clamp**, so that they will be just inside the top corners of the mat. Position the mat board and slip sheet under the **Border Clamps**. Locate the edge of the mat against the **Measuring Stop**, which is set for the B dimension. (See Figure 4.) Push the **Clamp Levers** down. The mat is now positioned 1" [25mm] from the **Clamp Scale**. See Figure 16.
3. Set the **Cutter Bar**, the **Disc Scale** and the **Yellow Beam Scales** as you would normally.
4. Follow steps 8, 9 and 10 in "Cutting Ovals" (page 10).



Figure 16

## Cutting Multiple Mats

With the Fletcher 1100, you can accurately cut multiple mats.

1. Cut a mat as you would normally. This will be the outer mat. Leave the **Measuring Stop** in place and remove the mat.
2. Position the second mat on the cutter, using the **Measuring Stop**. Reposition the **Cutter Bar** to the width of the inner mat oval. In our example, you might want  $1/4"$  [6mm] of the inner mat to be exposed, so you would set the width at  $4-1/2"$  [118mm], or  $1/2"$  [12mm] less than the width of the outer oval ( $5"$  [130mm]). Do not adjust the off-set on the **Disc** or the **Yellow Beams**. Cut the mat as you would normally.
3. Glue the two mats together, making sure that the top and left edges are even. See Figure 17.

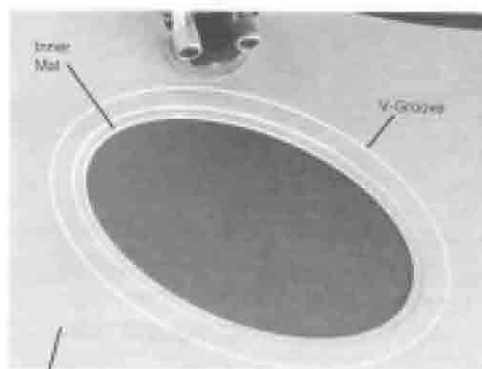

Figure 17

*Note:* You can also cut multiple mats by gluing them together before cutting. Cut the top mat first, being careful not to fully penetrate the inner mat. To cut the inner mat, remove the cut-out, reset the **Cutter Bar**, and cut the inner mat opening. This method guarantees that the openings will be perfectly concentric. (The dimension of the inner oval will be slightly smaller than shown on the **Cutter Bar Scale** because of the double mat. Adjust the **Cutter Bar** if desired.)

## Special Effects

You can create a variety of special effects with the Fletcher 1100. A few are explained below, but don't limit yourself to these examples. You can experiment by combining straight cutting (with the Fletcher 2100) with oval and circle cutting (with the Fletcher 1100); the bevel angle of both machines is the same. And remember, you can combine cuts and effects in many ways; for instance, you can cut v-grooves and multiple openings in multiple mats.

### Cutting Multiple Openings

Plan out your openings before you begin cutting. Know where the center of each oval is and the distance from the top and side edges.

1. Set the **Tee-Bar Scale** and position the mat under the **Clamp** for the first opening.
2. Set the **Cutter Bar**, **Disc** and **Yellow Beam Scales** as you would normally.
3. Follow steps 8, 9 and 10 in "Cutting Ovals" (page 10) to cut the first opening.
4. Repeat steps 1, 2 and 3 above for subsequent openings in the mat. See Figure 18.

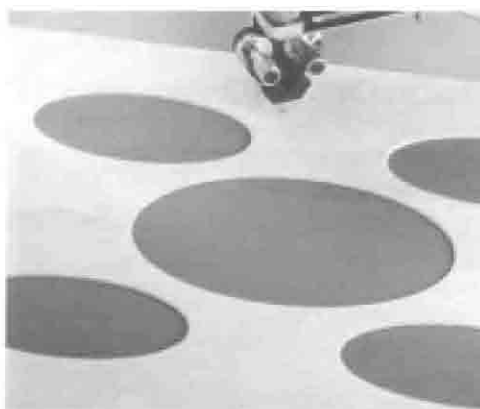

Figure 18

### Cutting Inlays

Select two or more mats of different colors. Plan the size of the openings and the width of the inlays before you begin cutting.

1. Cut the first mat as you would normally. Leave the **Measuring Stop** in place and remove the mat.
2. Cut the same size oval in the other mats.
3. Increase the setting on the **Cutter Bar**. Recut each mat and save the oval rings. Repeat this step if you wish.
4. Reassemble the mats by taping together alternate-color oval rings from the back. See Figure 19.

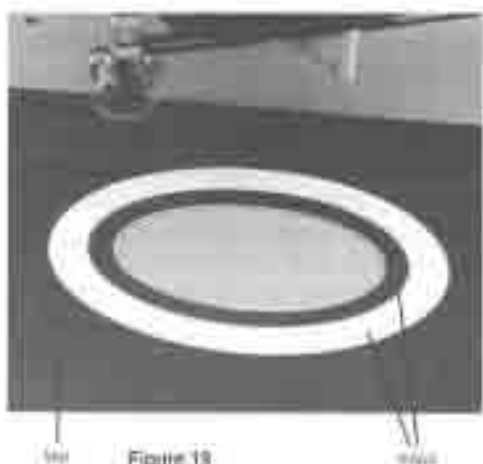

Figure 19

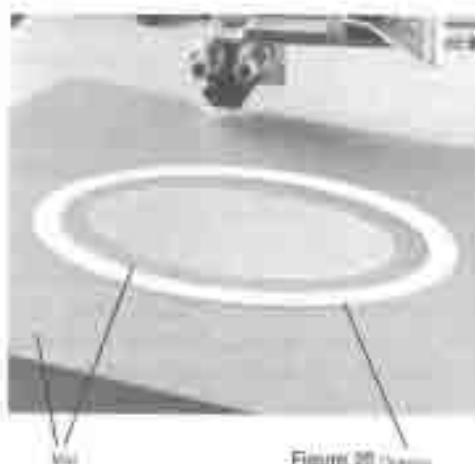

Figure 20

### Cutting overlays

1. Cut a mat as you would normally.
2. Cut a separate oval ring, larger than the opening you just cut, from another mat board. Reverse-bevel the outer edge of this ring by cutting with the right blade instead of the left blade.
3. Glue the oval ring to the top of the mat, evenly spaced around the opening. See Figure 20.

## CAUTION

Handle glass carefully. Wear protective gloves and safety glasses.

The Fletcher 1100 is equipped with a **Pillar Post** for cutting glass.

## Installing the Pillar Post

1. Insert the wheel unit in the slot in the **Pillar Post**. Seat it fully. Remove the **Blade Holder** by unscrewing the **Blade Holder Screw**. Replace it with the **Pillar Post** and tighten the **Blade Holder Screw**.

## Scoring the glass

2. Set the **Tee-Bar Scale** to the desired dimension. Position the glass directly on the **Base Board** without a slip sheet, align the glass to the **Clamp Scale**, and press down on the **Clamp Levers**. Turn the **Clamp Adjusting Knobs** if necessary.
3. Set the **Cutter Bar, Disc and Yellow Beam Scales** to cut the oval or circle.
4. Start with the **Handle** in the 9 o'clock position. Turn the **Knurled Thumb Knob** to lower the **Pillar Post** until the wheel touches the glass. Then, turn the **Thumb Knob** a bit more to be sure that the wheel is being pushed down by its spring. You can judge this by watching the alignment pin move up in its slot ( $1/16"$  [2mm] or more). See Figure 21.

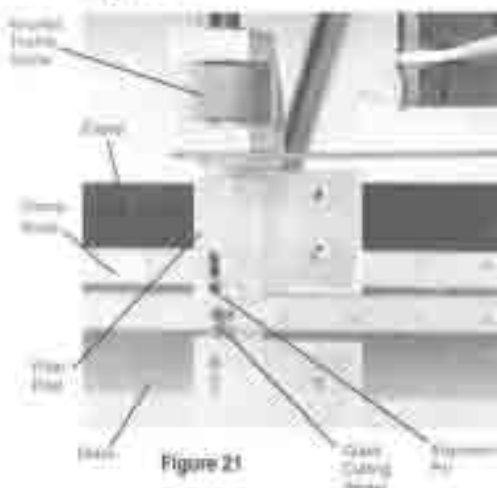

Figure 21

5. Rotate the **Handle** one full revolution counterclockwise. Stop when the wheel barely reaches its starting point. Do not score a second time. Raise the **Pillar Post**, unclamp the glass and remove it carefully.

## Breaking the glass out

6. Turn the glass upside-down on a flat but pliable surface, such as foam board. Place your thumb directly over the score line and gently press down. You will hear a slight snap and see the break run a short distance along the score line. Move your thumb over to the end of the break and gently press down again. Repeat until the break has traveled all the way around the cut-out.
7. Carefully turn the glass over so that the score is on top. Use a Fletcher hand glass cutter to score a few radial lines from near the cut-out to the edge of the glass. Do not score closer than  $1/8"$  [3 mm] to the cut-out; make sure you run the cutter completely off the edge of the glass. See Figure 22.

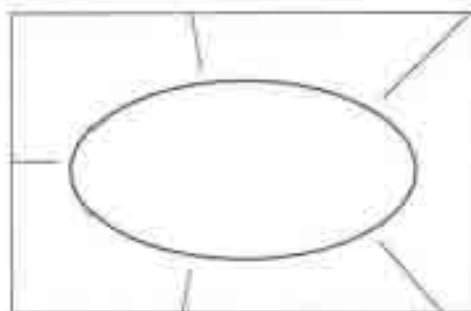

Figure 22

8. Separate the glass along each radial line with Fletcher Lightweight Cut-Running Pliers (06-111). Do this on a table surface so that the cut-out does not fall.
9. Discard the scrap pieces of glass in a proper container, and brush away any glass chips.



There is no need to lubricate the Fletcher 1100.

## Cleaning

The easiest way to keep your cutter in good condition is to keep it clean and free of dust and paper debris.

1. Occasionally, wipe the **Base Board** and other components with a clean, dry cloth.
2. Periodically, remove the **Disc** by unscrewing the **Handle Locking Knob**. Wipe the underside of the **Disc** and the plastic washer on which it rotates with a clean, dry cloth. Do not use abrasive materials to clean the **Disc**, because you may damage its surface. See Figure 23.

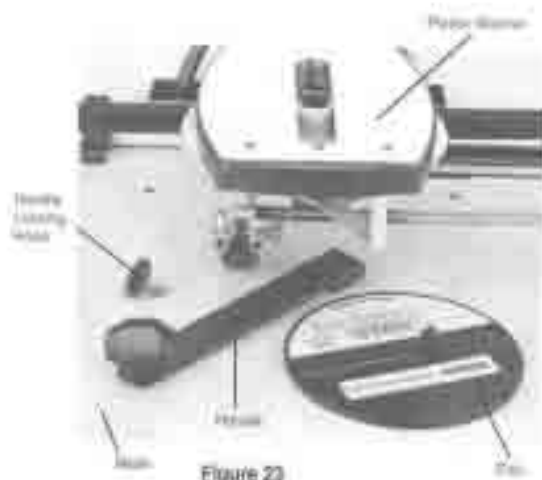

## Making Adjustments

You can solve most problems you encounter with the cutter by making the following adjustments. If you cannot, contact your Fletcher distributor or the Fletcher-Terry customer service department (1-800-THE-FTCO or 860-677-7331) for assistance.

Periodically, check the following parts for accuracy and adjust if necessary.

### Adjusting the Tee-Bar

Check the accuracy of the **Tee-Bar Scale**, which locates the center of a cut from the top edge of the mat, by setting it to 4-1/2" [120mm] and cutting a circle 3" [80mm] in diameter. The distance from the top of the circle to the top edge of the mat should be 3" [80mm]. If it is not, adjust the plastic indicator on the **Tee-Bar Block**.

Loosen the set screw on the **Tee-Bar Block** with a hex wrench from the parts bag. Slide the plastic indicator to a new position and tighten the set screw. Check and readjust if necessary. See Figure 24.

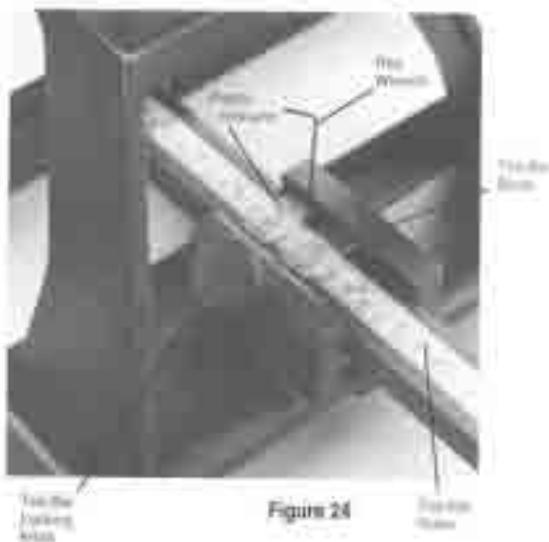

### Adjusting the Cutter Bar

Check the accuracy of the **Cutter Bar Scale**, which sets the width of a cut, by cutting a circle 3" [80mm] in diameter (as above). Measure the opening from the reverse side of the cut. If the opening is more or less than 3" [80mm] wide, adjust the **Cutter Bar Indicator**.

Loosen the phillips head screw on the **Cutter Bar Indicator** and slide it to the left or right. Tighten the screw. Check and readjust if necessary. See Figure 25.



Figure 25

### Adjusting the Disc Scale

Check the accuracy of the **Disc Scale**, which sets the off-set for an oval, by cutting an oval and measuring its length from the reverse side of the cut. If it is not correct, reposition the **Off-Set Indicator**.

Use the small hex wrench in the parts bag to loosen the set screw. Slide the plastic **Off-Set Indicator** to a new position and tighten the set screw. Check and readjust if necessary. See Figure 26.

### Adjusting the Zero Block

To be sure that circles are true, set the **Disc Scale** to zero and slowly rotate the **Handle**. While rotating, watch the right edge of the **Disc** in relation to the edge of the **Cantilever Beam**. The distance should not vary during rotation. If it does, adjust the **Zero Block**.

Use a hex wrench from the parts bag to adjust the set screw. Check and readjust if necessary. See Figure 27.

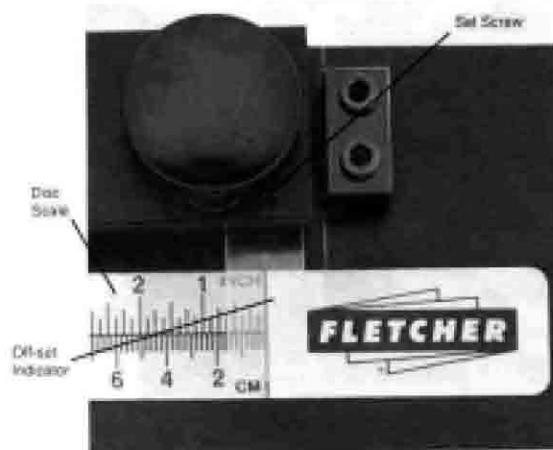

Figure 26

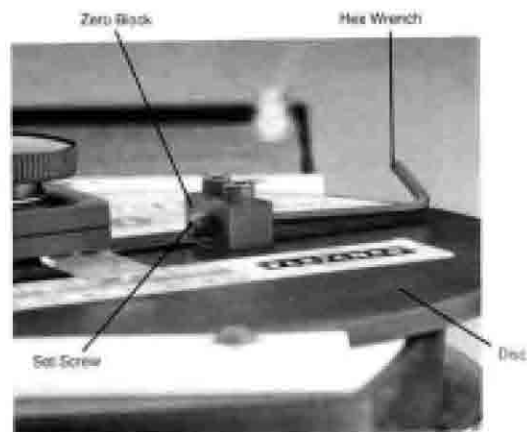

Figure 27

### Adjusting the Front Gibb

There should be minimum, even clearance between the **Disc** and the **Gibbs** that guide it back and forth. If there is not enough clearance, the **Handle** will be difficult to turn; if there is too much, the ovals will not be perfect. Do not try to reposition the **Back Gibb**.

Adjust for proper positioning by slightly loosening the three button head screws in the **Front Gibb**. Set the off-sets to 6" and rotate the **Handle** so that the **Disc** is positioned at one of the screws. Place a piece of writing paper between the **Front Gibb** and the **Disc** and tighten the screw. Repeat this for the other two screws on the **Front Gibb**. See Figure 28.

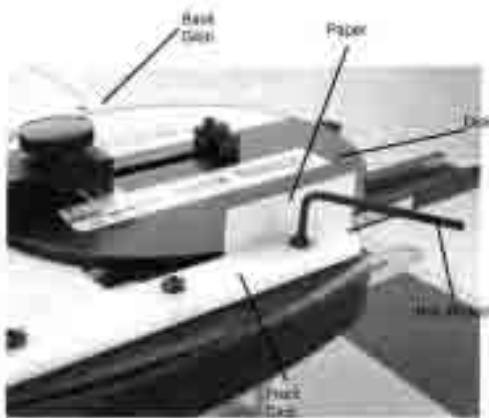

Figure 28

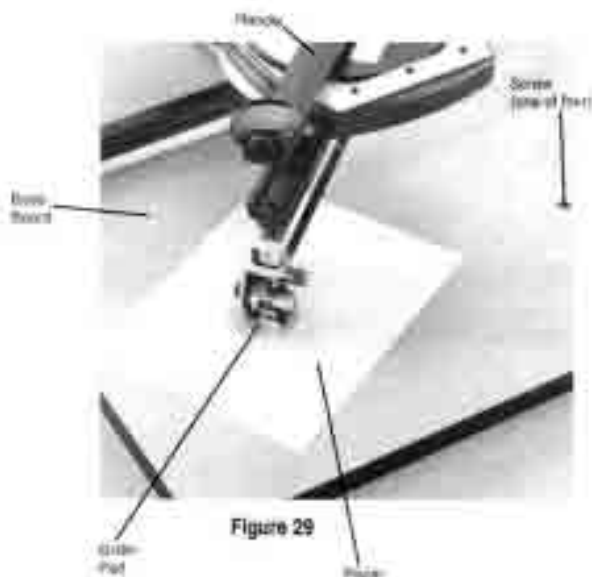

Figure 29

### Adjusting the Base Board

The **Base Board** is mounted on four springs and held in place by four flat head hex screws. The **Base Board** must be the same distance from the **Glider Pad** throughout its rotation to ensure an accurate cut.

To check the position of the **Base Board**, remove the slip sheet. Rotate the **Handle** so that the **Glider Pad** is near one of the hex screws. Place a sheet of writing paper on the **Base Board** and lower the **Glider Pad** so that it creates a slight drag when you pull the paper. With the **Glider Pad** still lowered, rotate it near another hex screw and pull on the paper to determine if the drag is the same. Repeat at the other two hex screws.

If you feel a difference in the drag at any location, use a hex wrench from the parts bag to turn the screw in or out to lower or raise the **Base Board**. Check and readjust if necessary. See Figure 29.

### Adjusting the Blade Holder

To ensure crisp, accurate cuts, the blades should move freely in the **Blade Holder**, without any looseness or wobbling.

Adjust the set screws to permit the blades to barely slide in the **Holder** without binding. See Figure 30.

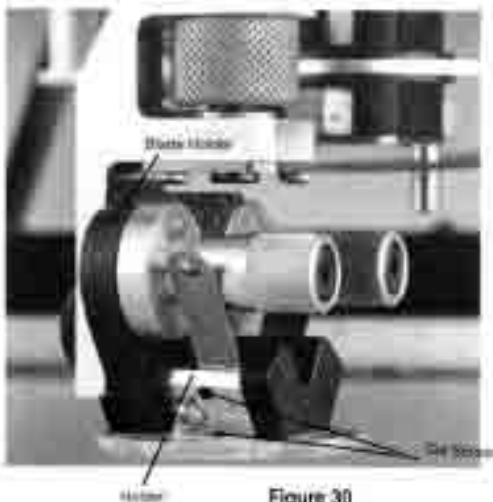
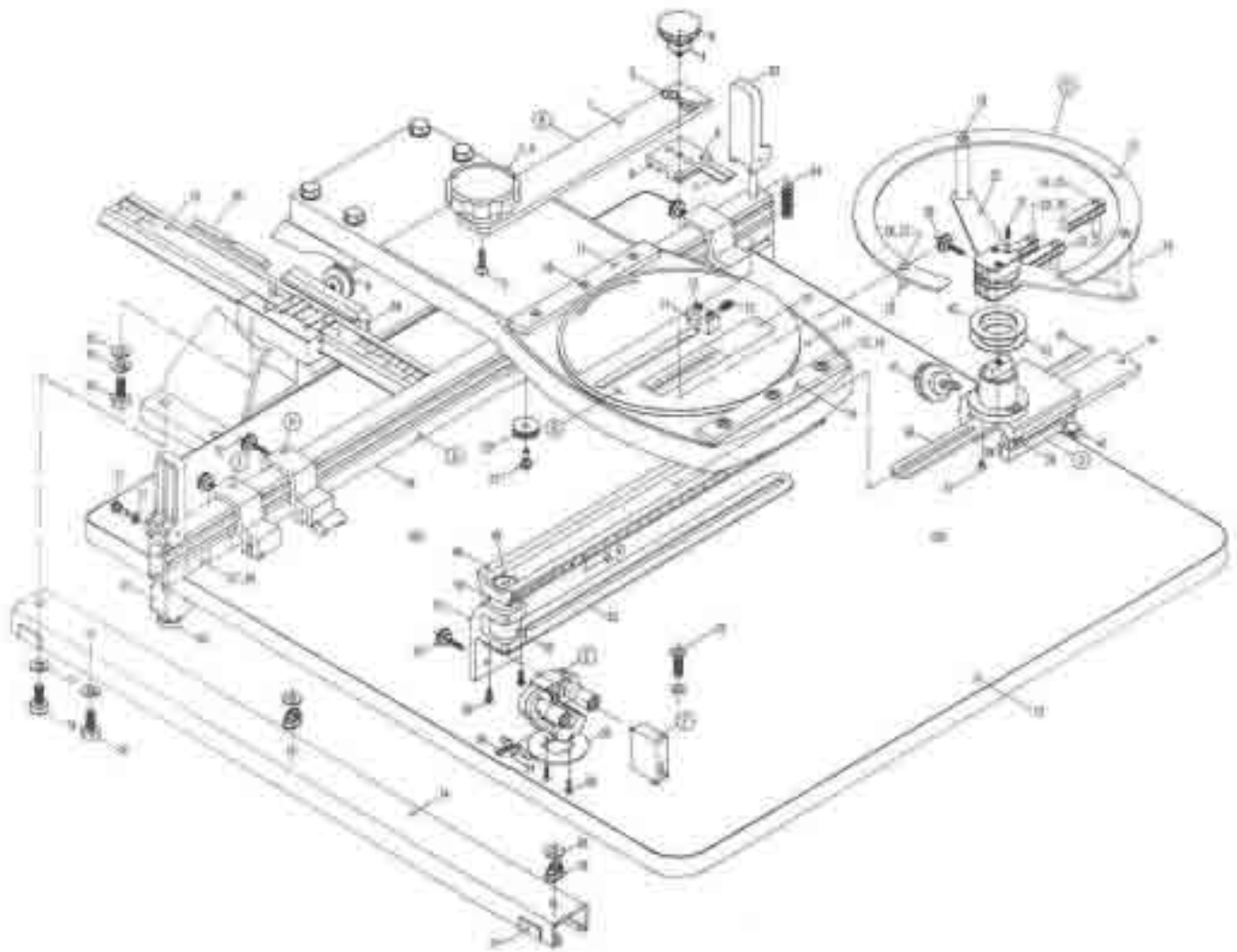

Figure 30

*Assembly View*



## Parts List

REF	ORDER NO.	DESCRIPTION	QTY	REF	ORDER NO.	DESCRIPTION	QTY
A	12-390	<b>HANDLE ASSEMBLY</b>	1	39	12-040	PAN HEAD MACHINE SCREW	5
1	12-391	HANDLE	1	40	12-338	SLIDE KNOB	1
2	12-317	HANDLE KNOB	1	41	12-350	CUTTER BAR LOCKING KNOB	1
3	12-320	FLAT HEAD CAP SCREW	1	42	12-334	WASHER	1
4	12-318	WASHER	2	43	12-335	SHIM WASHER	1
5	12-321	FLAT HEAD CAP SCREW	2	44	12-357	SLIDE BAR ASSEMBLY	1
6	12-065	SET SCREW	3	45	12-349	SHOE	2
7	12-324	OFF-SET INDICATOR (RED)	2	46	12-404	CUTTER BAR	1
8	12-392	OFF-SET LOCK CAP	1	47	12-405	CUTTER BAR SCALE (INCH)	1
9	12-322	HANDLE & TEE-BAR LOCKING KNOB	2	48	12-406	CUTTER BAR SCALE (MM)	1
B	12-393	<b>DISC ASSEMBLY</b>	1	49	12-342	FLAT HEAD CAP SCREW	1
10	12-326	DISC SCALE	1	50	12-343	CUTTER SHAFT	1
11	12-394	ZERO BLOCK	1	51	12-407	MOUNTING PIVOT ASSEMBLY	1
12	12-395	SOCKET HEAD CAP SCREW	2	52	12-344	KNURLED THUMB KNOB	1
13	12-396	SET SCREW	1	53	12-408	GUIDE BAR	1
14	12-315	FRONT GIBB	1	E	12-409	<b>BLADE HOLDER ASSEMBLY</b>	1
15	12-314	BUTTON HEAD CAP SCREW	3	54	12-114	BLADE SET SCREW	4
16	24-130	WASHER	3	55	12-410	GLIDER PAD	1
17	12-313	BACK GIBB	1	56	12-411	FLAT HEAD CAP SCREW	2
18	12-312	FLAT HEAD CAP SCREW	7	57	12-365	BLADE HOLDER SCREW	1
19	12-316	DISC WASHER	1	F	12-412	<b>PILLAR POST ASSEMBLY</b>	1
20	12-328	ROLLER	4	58	12-413	TEE-BAR BLOCK	1
21	12-329	SHOULDER SCREW	6	59	12-414	OFF-SET INDICATOR (BLACK)	1
C	12-397	<b>BOOMERANG ASSEMBLY</b>	1	60	12-380	HEX HEAD BOLT	3
22	12-398	BOOMERANG SUB ASSEMBLY	1	61	24-153	LOCK WASHER	3
23	12-331	CENTER RING	1	62	36-023	WASHER	7
24	12-356	POST	2	G	12-415	<b>TEE-BAR ASSEMBLY</b>	1
25	12-330	GUIDE PIN	1	63	12-372	CLAMP LEVER ASSEMBLY	2
26	12-332	RETAINING RING	1	64	12-416	COMPRESSION SPRING	2
27	12-399	SHIM WASHER	1	65	12-374	BASE CLAMP	2
28	12-354	LOWER YELLOW BEAM LOCKING KNOB	1	66	12-375	CLAMP ADJUSTING KNOB	2
29	12-358	UPPER YELLOW BEAM ASSEMBLY (INCH)	1	67	12-370	CLAMP SCALE (INCH)	1
30	12-400	UPPER YELLOW BEAM ASSEMBLY (MM)	1	68	12-371	CLAMP SCALE (MM)	1
31	12-381	SET SCREW	1	69	12-417	CLAMP TAPE	1
32	12-362	LONG LOWER YELLOW BEAM ASSY. (INCH)	1	70	12-418	TEE-BAR SCALE	1
33	12-401	LONG LOWER YELLOW BEAM ASSY. (MM)	1	71	12-376	NYLON WASHER	2
34	12-385	SHORT LOWER YELLOW BEAM ASSY. (INCH)	1	H	12-419	<b>MEASURING STOP ASSEMBLY</b>	1
35	12-402	SHORT LOWER YELLOW BEAM ASSY. (MM)	1	I	12-420	<b>BORDER CLAMP ASSEMBLY</b>	2
D	12-403	<b>CUTTER HOUSING ASSEMBLY</b>	1	72	12-387	PLASTIC KNOB	3
36	12-347	GUIDE BRACKET	1	73	12-421	BASE BOARD	1
37	12-346	FLAT HEAD UNDERCUT SCREW	2	74	12-422	BASE RUNNER ASSEMBLY	2
38	12-039	CUTTER BAR INDICATOR	1	75	12-305	FLAT HEAD CAP SCREW	4
				76	12-304	CONICAL SPRING	4
				77	36-020	LOCK WASHER	4
				78	12-306	HEX HEAD BOLT	4
				79	12-307	ANTI-SLIP PAD	4

## Troubleshooting

PROBLEM	POSSIBLE CAUSE	ACTION	REFERENCE
Regged out in the mat.	Dull blade. Slip sheet worn.	Replace the blade. Replace slip sheet. Move slip sheet to new position.	SET UP Cutting Mats Cutting Mats
Circle diameter and oval width not correct.	Cutter Bar Indicator out of adjustment.	Reposition the Cutter Bar Indicator.	Maintaining the Fletcher 1100
Oval length not correct.	Disc scale out of adjustment.	Reposition the Off-Set Indicator.	Maintaining the Fletcher 1100
Rotating mechanism does not turn freely.	Yellow Beams not set correctly. Using long yellow beam with width set to less than 4" (100mm).	Check Yellow Beam Scales and set properly. Use short lower Yellow Beam.	Cutting Mats Cutting Mats
Mat not securely clamped.	Clamp set too high.	Turn the Clamp Adjusting Knobs under each end of Clamp.	Cutting Mats
Surface of mat "gazed" along cutting path.	Glider Pad touching mat with too much pressure.	Lower Blade Holder so that Glider Pad barely touches the mat.	Cutting Mats
V-groove width is uneven.	Base Board not same distance from blade at all points of rotation.	Readjust the Base Board flat head.	Maintaining the Fletcher 1100