

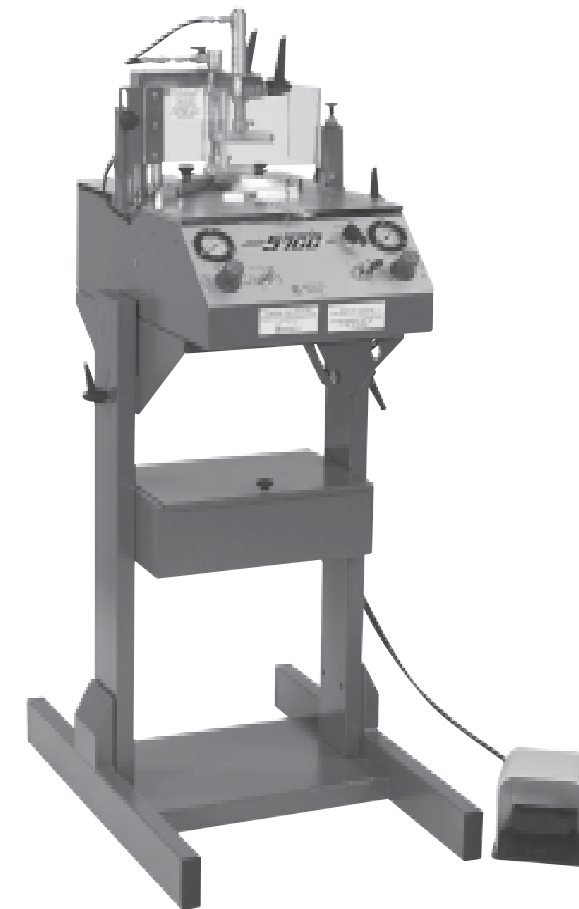

OWNER'S MANUAL

FLETCHER 5700 CORNERPRO™



*All 5700 Photos in Manual show machine
with accessories (stand & double-presser foot)*

The Fletcher-Terry Company
65 Spring Lane • Farmington, CT 06032-3311
Tel 860.677.7331 • 800.843.3826 • Fax 860.676.8858 • www.fletcher-terry.com
customerservice@fletcher-terry.com

TABLE OF CONTENTS

INTRODUCTION	3
Components	3
Optional Accessories	3
Specifications / Capacity	3
PRODUCT WARRANTY	4
SAFETY	4
GENERAL DESCRIPTION	5
SET UP	6
HOW TO SELECT NAILS	6
HOW TO LOAD NAILS	7
HOW TO JOIN FRAMES	7
HOW TO DRIVE NAILS	8
FENCE ADJUSTMENT	8
MAINTENANCE	9
TROUBLESHOOTING	10
SPARE PARTS	11

SPARE PARTS

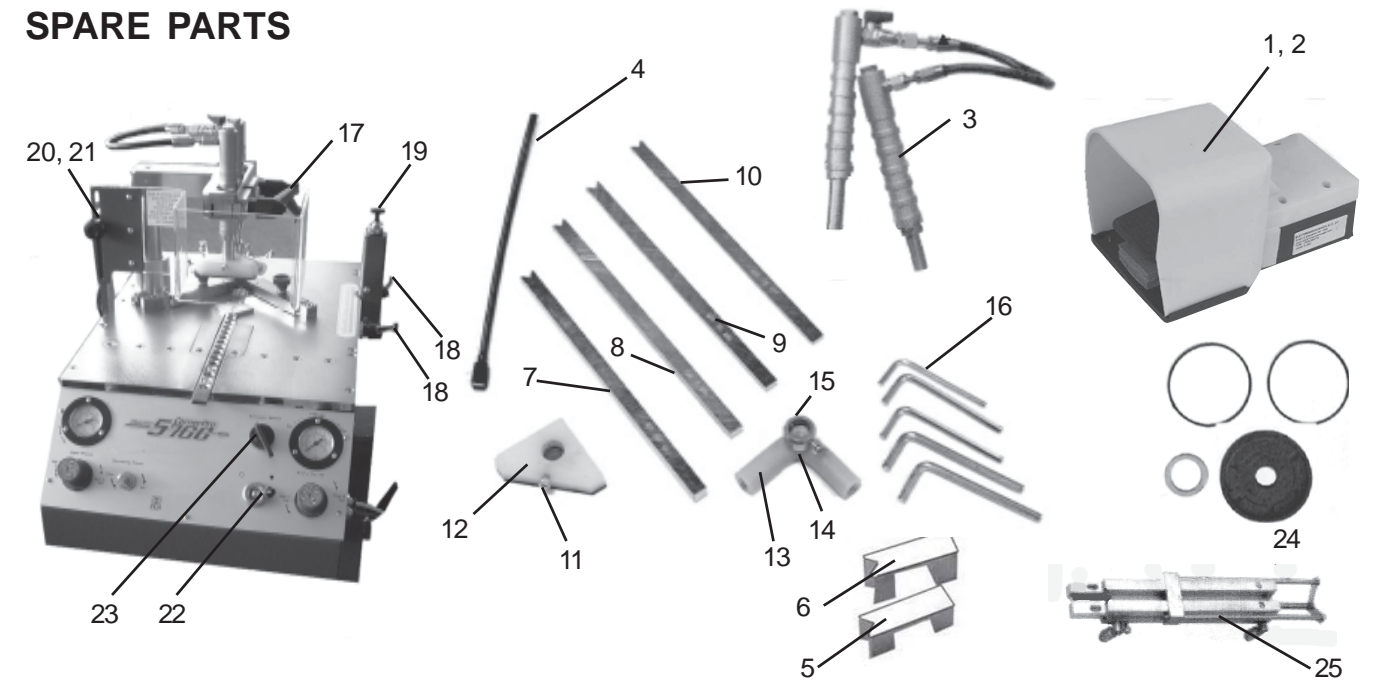

<u>Ref. No.</u>	<u>Part No.</u>	<u>Description</u>	<u>Quantity</u>
1	16-064	Complete Foot Pedal	1
2	16-065	3 Way Foot Pedal Valve	1
3	16-055	Self Leveling Double Clamp	1
4	16-013	Magnet	1
5	16-043	Pusher (4mm, 7mm)	1
6	16-044	Pusher (10mm, 12mm, 15mm)	1
7	04-344	4mm Compensator	1
8	16-041	7mm Compensator	1
9	16-042	10mm Compensator	1
10	04-347	12mm Compensator	1
11	16-039	Flat Angular Pad	1
12	16-040	Flat Angular Pad Screw	1
13	16-037	Round Angular Pad	1
14	16-036	Round Angular Pad Screw	1
15	16-038	Round Angular Pad Bushing	1
16	16-074	Hex Wrench Set (5)	1
17	16-061	Locking Knob	2
18	16-063	Stop Locking Knob	2
19	16-075	Push Button and Valve	1
20	16-006	Guard Knob	1
21	16-005	Guard Valve	1
22	16-066	Loader Toggle Switch and Valve	1
23	16-067	Automatic/Manual Switch and Valve	1
24	16-054	Cylinder Gasket Set	1
25	16-051	Nail Loader	1
26*	16-062	1-1/2" (40mm) Round Pad	1

* Not shown

TROUBLESHOOTING

PROBLEM	POSSIBLE CAUSE	CORRECTION
Sound of leaking air	Leaking at the air source nipple	Remove the air hose and reattach it
	Leak at one of the hose connections to a valve	Feel for air leak, cut off 1/2" of hose and insert it again
	Pressure regulator set at more than 115 PSI (8 BAR)	Set the regulator at less than 115 PSI (8 BAR)
	Leakage in a valve or a cylinder	Contact Customer Service (see below)
Leak disappears when foot pedal is depressed	Hose connections between foot pedal and machine leaking	Reattach hoses at the foot pedal and the machine
Nail is not driven	Regulator set too low	Set regulator above 37 PSI (2.5 BAR)
	Nails jammed at hammer block	Remove nails and clean nail path
	Nails placed backwards in nail path	Remove and reload strip of nails
	Foot pedal operated too fast	Try again more slowly
	Follower not pushing strip of nails into position	Remove obstruction in nail path
	Wrong thickness compensator or not installed correctly	Replace thickness compensator and insert it properly
	Nails placed backwards in nail path	Remove and reload strip of nails
	Edge of hammer is worn or damaged	Contact Customer Service (see below)
	The last 1/4 of the strip of nails will not feed	Add more nails
	Edge of hammer is worn or damaged	Contact Customer Service (see below)
Nail only partially driven into moulding	No nails in the nail path	Load nails
	Air pressure set too low	Set regulator above 2.5 BAR (37 PSI)
	Upper clamps set too high above the frame	Position upper clamps 3/4" to 1" above moulding
	Edge of hammer is worn or damaged	Contact Customer Service (see below)
Push button does not insert nail	Upper clamp pad out of position	Re-position the upper clamp
	Automatic/Manual switch set to Automatic	Set switch to Manual
	Push button valve clogged	Clean push button valve
Foot pedal does not activate cycle	Push button worn or damaged	Replace push button and valve (16-075)
	Foot pedal return spring broken	Contact Customer Service (see below)
	Air line not connected	Check line connection
	Valve is clogged or air line is blocked	Remove air line, clear obstruction, reattach
	Valve faulty	Contact Customer Service (see below)
	Air pressure set too low	Set regulator above 2.5 BAR (37 PSI)
	Automatic/Manual switch set to manual	Set switch to automatic

FOR ASSISTANCE, CONTACT THE FLETCHER-TERRY COMPANY CUSTOMER SERVICE DEPARTMENT AT 800.843.3826 (U.S./CANADA) OR 860.677.7331, customerservice@fletcher-terry.com.

INTRODUCTION

The Fletcher 5700 CornerPro™ is a pneumatically powered underpinner which is designed to be operated on a work table or a tilting **Stand**. A Plexiglas® shield is provided to safeguard against pinching your fingers with the pneumatic clamping of the moulding and insertion of nails. It is interlocked with the underpinning operation to prevent the use of the machine unless the guard is in place. Respect the importance of this safety feature for your protection.

•The 5700 CornerPro™ includes the following:

- Front Clamp (adjustable)
- Two Upper independently adjustable equal force Clamps
- Interchangeable Upper Clamp Pads:
 - Flat Right Angle Pad
 - Round Right Angle Pad
 - 1-1/2" (40mm) Round Pad
- Two Nail Pushers:
 - One for 3/16" and 1/4" (4mm and 7mm) Nails
 - One for 3/8", 1/2" and 5/8" (10mm, 12mm and 15mm) Nails
- Four Thickness Compensators:
 - One for 3/16" (4mm) Nails
 - One for 1/4" (7mm) Nails
 - One for 3/8" (10mm) Nails
 - One for 1/2" (12mm) Nails
- Tool Box Containing:
 - Metric Hex Wrench Set (5)
 - Magnet
 - Owner's Manual
 - Instructional Video
 - Pneumatic Nail Loading System

•Optional Accessories:

	<u>Part No.</u>
Tilting Stand.....	04-356
Closet Stand.....	04-325
Extension Wings.....	04-341
Fence Risers.....	04-342
Work Table.....	04-343
Air Filter/Lubricator.....	04-348
Automatic Gluing System.....	04-352
Hexagonal and Octagonal Fences.....	04-353
Counterweight Balancer (for use with tilting stand)....	04-354

•Specifications:

Width	15-3/4" (400mm)
Depth	21-5/8" (550mm)
Height (without stand)	15-3/4" (400mm)
Weight (without stand)	100-3/4 lbs. (45.7kg)
Minimum Air Pressure required	37 PSI (2.5 BAR)
Maximum Air Pressure	115 PSI (8 BAR)

•Moulding Capacity:

Height*	1/4" to 4-1/8" (5mm to 105mm)
Width	5/16" to 5-1/8" (8mm to 130mm)
Maximum Variation in Height using both Upper Clamps	2-3/8" (60mm)

*Use 3/16" (4mm) Nail only for 1/4" moulding height.

PRODUCT WARRANTY

The Fletcher-Terry Company warrants the Fletcher 5700 CornerPro™ to be free from defects in parts and workmanship for (2) two years from the date of purchase, *with the exception of those parts and accessories listed below. The Fletcher-Terry Company warrants that it will repair or replace any such defective machine or replace parts, providing the machine has been under normal use and service and the defective part or machine is returned to The Fletcher-Terry Company at the purchaser's expense. The Fletcher-Terry Company must authorize the return in writing. Proof of purchase must be submitted to validate warranty coverage.

The warranty is in lieu of all other agreements and warranties expressed or implied. THE FLETCHER-TERRY COMPANY DOES HEREBY EXPRESSLY DISCLAIM ANY WARRANTIES OF MERCHANTABILITY OR FITNESS FOR A PARTICULAR PURPOSE. The Fletcher-Terry Company does not authorize any company employee or representative to assume for it any other liability than that set forth in this Product Warranty. The Fletcher-Terry Company shall not be liable for any damages or losses, whether incidental or consequential or direct or indirect, arising out of the use or abuse of this machine; in any event, THE PURCHASER'S SOLE AND EXCLUSIVE REMEDY UNDER THIS OR ANY OTHER WARRANTY IS LIMITED TO RETURN OF THE PURCHASE PRICE PAID FOR THIS MACHINE.

**Parts and accessories not included in the (2) two year warranty:*

<u>Description</u>	<u>Description</u>
Complete Foot Pedal	Thickness Compensator - 4mm
Plexiglas® Guard	Thickness Compensator - 7mm
All Locking Levers	Thickness Compensator - 10mm
All Adjusting Knobs	Thickness Compensator - 12mm
Complete Tool Box	Nail Pusher - 4-7mm
Hex Wrenches	Nail Pusher - 10-15mm
Magnet Rod	Fence Risers
Round Right Angle Pad	Extension Wings
Flat Right Angle Pad	40mm Round Felt Pad
Millimeter Scale	

•Hammer is warranted for (1) one year.

Damage resulting from the use of joining nails other than CornerPro nails or unauthorized modifications to the machine will void the warranty.

SAFETY

- Follow the operating instructions in this manual.
- Keep your fingers away from clamping areas both front and upper.
- Wear safety glasses during operation, maintenance assembly and disassembly activities.
- Do not rest your foot on the foot pedal until you are ready to operate the clamps and drive a nail.
- Do not operate this machine without the Plexiglas® Guard in place.
- Disconnect air source during maintenance.

MAINTENANCE

Caution: Disconnect air source and wear safety glasses during maintenance.

Recommended frequency of the following maintenance activity:

- Item 1 Daily
- Item 2 As required
- Item 3 Weekly
- Item 4 Monthly
- Item 6..... Weekly

Modify these frequencies as environment and usage dictate. This machine will provide years of quality performance if well cared for.

1. The most important maintenance requirement is cleanliness. Use a brush or clean cloth to wipe the table surface, Shafts and Pads.
2. If glue accumulates on the **Hammer Block (H)**, (Figure 13), wipe it off before it dries, otherwise, it will have to be scraped off or removed with the solvent recommended by the glue manufacturer. Be sure glue does not dry on the **Upper Clamp Pads** because it will damage the top of a frame.
3. Use light oil on a cloth to wipe the vertical shaft (**L**) in Figure 10 which operates the **Upper Clamps**. Clean out the **Foot Pedal** and all of the porous silencers on the pneumatic valves using commercially available air pressure cans.

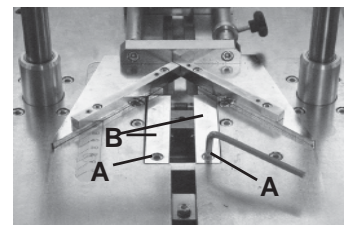

Figure 12

4. Remove the **Pusher**, all **Nails**, and the **Compensator** and disassemble the **Hammer Block** and clean as follows:

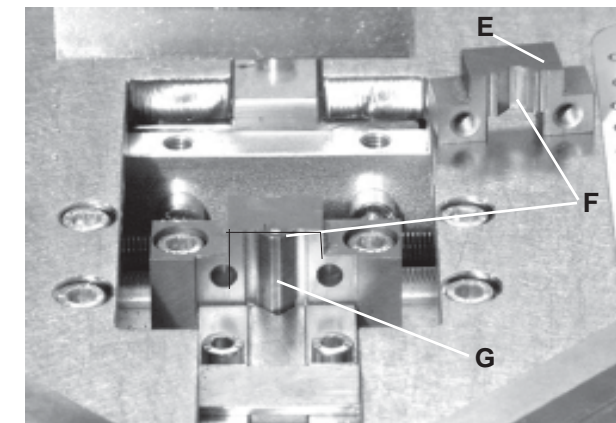

Figure 14

- a. Remove screws (**A**) and set the **Cover Plates (B)** aside. (Figure 12)
- b. Remove two screws (**C**). **DO NOT LOOSEN SCREWS (D)**. (Figure13)

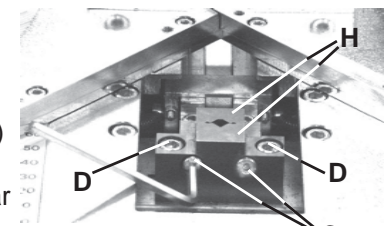

Figure 13

- c. Figure 14 is viewed from the rear. Remove the rear half of the **Hammer Block (E)** and wipe the hammer path (**F**) clean.
- d. Depress the **Foot Pedal** to expose the **Hammer (G)** and wipe it clean.

5. Re-assemble the **Hammer Block** components in the reverse order of steps a. through d.

Caution: Be sure the tops of the two halves of the **Hammer Block (H)** in Figure 13, are perfectly flush before tightening screws (**C**).

6. Check the lubricant and drain the filter. The lubricator should produce one drop for every 30 - 40 foot pedal cycles.

HOW TO DRIVE NAILS

1. Set the **Automatic/Manual** switch on the front panel to **MANUAL**.
2. Slide the **Operating Handle (F)** to the **Rear Stop (G)** for the position of the first **Nail**. Place both frame pieces against the **Fence** with their top surfaces flush and the corner even. Set the **Front Clamp** in place with the **Clamp 3/8"** (10mm) to 5/8" (15mm) from the rabbet of the frame. Make sure your hands are clear of the clamping areas. Depress the **Foot Pedal** and the **Front Clamp** will operate immediately followed by the **Upper Clamps**. Continue to hold the **Foot Pedal** down and press the **Push Button (K)** on top of the **Operating Handle (F)** and the first **Nail** will be inserted. Move the **Front Clamp** out of the way and slide the **Operating Handle (F)** to the front against its stop **(H)**. Position the **Front Clamp 3/8"** (10mm) to 5/8" (15mm) from the rabbet of the frame and depress the **Push Button** again to insert the second **Nail**. Since the frame is higher near the corner, you can drive another **Nail** at this same location which stacks two **Nails**, one on top of the other. If the frame is wide, you can move the **Operating Handle (F)** to one or more intermediate positions, re-positioning the **Front Clamp** each time, and insert additional **Nails**. Now, release the **Foot Pedal** and remove the moulding.
3. A general rule is the height of the **Nail** should be at least 3/16" shorter than the height of the frame and more than half the frame height. To achieve this may require stacking two or more **Nails**, one above the other, in soft to medium wood. In harder wood, it is better to stack the 3/16", 1/4" or 3/8" (4mm, 7mm, or 10mm) **Nails** than the 1/2" or 5/8" (12mm or 15mm) **Nails**.

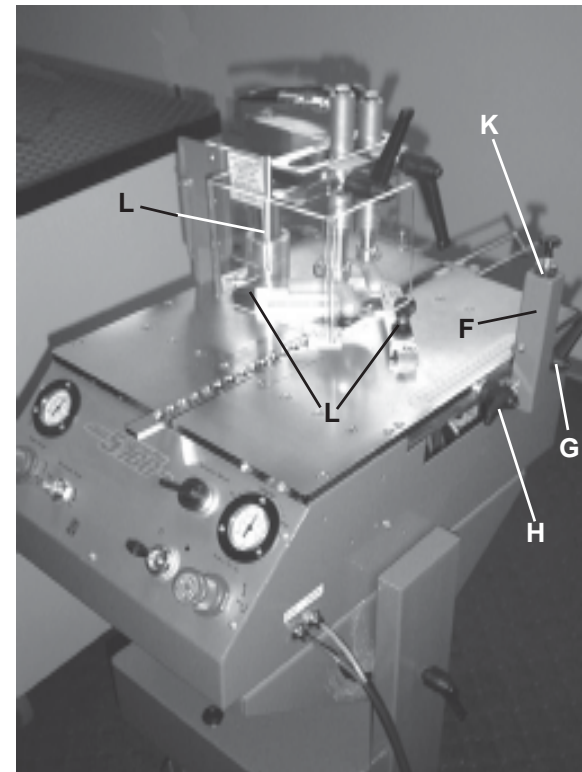

Figure 10

FENCE ADJUSTMENT

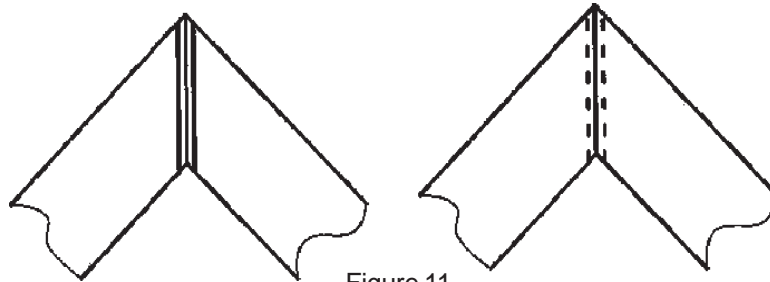

Figure 11

The **Fence** sides can be tilted +/- 3° by turning **Knobs (L)** to accommodate the incline of the rear of the frame or twist in the mouldings. Figure 11 shows exaggerated views of two common problems. The moulding on the left is open at the top. Rotate the **Knobs (L)** counterclockwise to tilt the **Fence** legs to close the gap. The moulding on the right is open at the bottom. Turning the **Knobs (L)** clockwise will help close this joint. In both cases, more pressure may be required on the **Front Clamp**. Correcting such

misalignment is limited and the error accumulates until the fourth corner becomes very difficult to join. Good corner joining is dependent on accurate mitering and quality wood mouldings.

GENERAL DESCRIPTION

1. The Fletcher 5700 CornerPro™ is versatile. It has two **Upper Clamp** assemblies allowing you to provide proper support for wide frames with complex profiles. The downward pressure is applied equally to both. Or one **Upper Clamp** can be hydraulically isolated and retracted out of the way permitting the other **Upper Clamp** to be used for small narrow frames.
2. The **Hammer Block** is moved from one nail position to the next while the moulding and **Fence** remain clamped and locked in one position.
3. The machine can operate in either **Automatic** or **Manual** mode under the control of a switch on the front panel. In **Automatic** mode, the **Foot Pedal** not only actuates the **Upper** and **Front Clamps**, but also drives the **Hammer** to insert a **Nail**. In the **Manual** mode, the **Foot Pedal** only operates the **Clamps** while the **Push Button** activates the **Hammer** to insert a **Nail**.
4. A pneumatically powered mechanism retracts the **Nail Loader** to load or change **Nails**.
5. Both the **Front Clamp** and **Upper Clamps** have independent air pressure regulators while the **Nail** Insertion cylinder operates at line pressure.
6. The speed of descent of the **Upper Clamps** is controllable and important when working with fragile or delicate frame surfaces.

IMPORTANT: A Plexiglas® Guard encloses the moving components on top of the machine to prevent injury to the operator. The pneumatic system will not function if this guard is not in place. Respect this feature for your own protection.

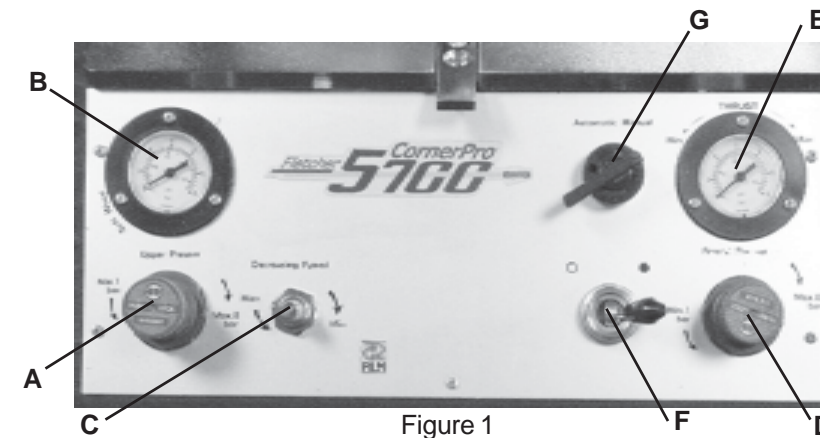
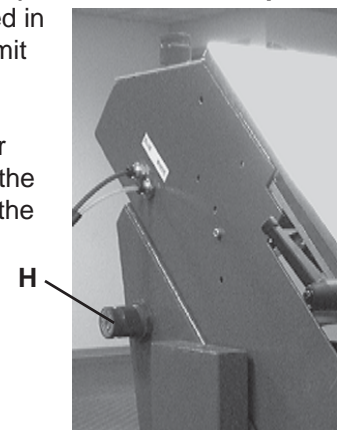

Figure 1

7. The control valves are shown on the front panel in Figure 1. **(A)** is the regulator for air pressure to operate the **Upper Clamp** assembly. The air pressure gauge **(B)** displays the resultant pressure. The Valve **(C)** controls the speed of travel of the **Upper Clamps**. Clockwise decreases the speed while counterclockwise increases speed of descent. The Regulator **(D)** sets the air pressure, (displayed in the pressure gauge) **(E)**, for the **Front Clamp**.

The Valve **(G)** sets the mode of operation to be **Automatic** or **Manual** as described in item 3 above. The **Toggle valve (F)** retracts or advances the **Nail Loader** to permit loading and unloading **Nails, Compensators** and **Pushers**.

The panel around both pressure gauges is marked with recommended settings for different wood. The **Counterweight Balancer** option provides a regulator **(H)** on the left side of the **Stand** to off set the weight of the **Hammer Block** assembly when the machine is tilted. See the illustration on the right, viewed from the rear.



SET UP

Unpack the machine and examine all components for shipping damage which should be reported to the carrier for claims.

- Two people are required to lift the machine to a work table of comfortable height or to the top of the **Tilting Stand** if this option was obtained. Mount it securely with the fastening bolts and nuts provided. Set the **Foot Pedal** on the floor near the work table or the **Stand**.
- Remove the **Plexiglas® Guard** for the following three steps.
- Remove the **Front Clamp** and move the **Upper Clamp** assembly up and away from the **Hammer Block**.
- Two color-coded **Foot Pedal** air hoses should be connected to the matching color coded receivers on the machine. The connection is made by firmly pushing the hose into the receiver. When properly done, the hose will slide into the receiver about 3/8".
- Attach the compressed air source to the machine with the appropriate "quick disconnect" fitting. The source should be filtered and lubricated and not exceed 115 PSI (8 BAR).
- REINSTALL THE PLEXIGLAS® GUARD.**

HOW TO SELECT NAILS

	3/16" (4mm)	1/4" (7mm)	3/8" (10mm)	1/2" (12mm)	5/8" (15mm)
Hardwood Order No.	08-320	08-321	08-322	08-323	08-324
Softwood Order No.	08-320	08-326	08-327	08-328	08-329

Figure 2

The patented joining **Nails** are designed to apply forces which hold the frame pieces firmly together creating a tight joint. There are 5 different lengths as shown in Figure 2. Each size is available for either hardwood or softwood with the order number shown for each. Select the nail length which comes no closer to the top of the frame than 3/16" to 1/4". See Figure 3. For maximum strength, place two or more nails (**A**) and (**B**) in parallel as shown.

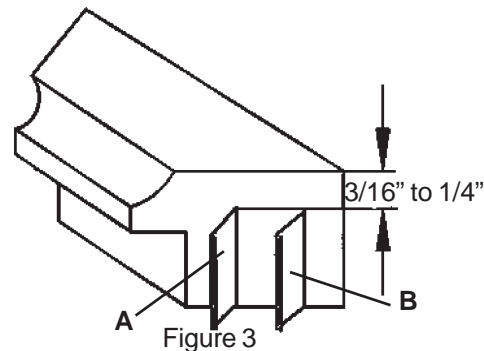

NOTE: Use only the nails shown above provided by Fletcher-Terry or the machine may be damaged and the Warranty voided.

HOW TO LOAD NAILS

- Operate the **Toggle Switch (F)** on the front panel, Page 5, to retract the **Loader**, Figure 9. Slide the **Compensator** labelled 10mm (**K**) into the **Nail** path with the pin in the **Compensator** facing downward and the notch forward. Press down on the rear of the **Compensator** after it is fully inserted and it will lock in

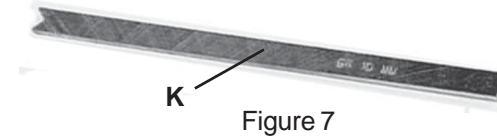

Figure 7

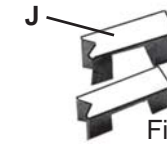

Figure 8

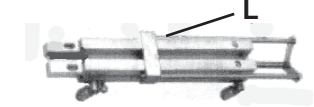

Figure 9

place. Slide a strip of 3/8" (10mm) **Nails** in the **Nail** path on top of the **Compensator** with the glue side up and the bend in the **Nails** matching the angle of the **Fence** and moulding corner. Place the larger of the two **Pushers (J)** across the **Nail Block (L)** with the notched end of the **Pusher** against the **Nails**. Operate the **Toggle Switch** again and the **Nail** loader will push the **Nails** into the **Hammer Block** and you are now ready to insert **Nails**.

- Set the **Automatic/Manual** switch to **Automatic**. Make sure your hands are clear of the clamp areas. Depress the **Foot Pedal** and a **Nail** will be pushed up out of the **Hammer Block** to verify the **Nails** are properly loaded and the **Hammer Block** is free of obstructions. Drive several **Nails** when the machine is new or has not been used for a week or more.
- Re-install the **Front Clamp**.

HOW TO JOIN FRAMES

- Loosen **Locking Levers (D and E)** and slide the two cylinders so they are positioned over the frame corner as suggested in Figure 4. The intent is to provide backing support for the insertion of **Nails** along the joint in the frame. The 5700 can accommodate a difference in height of the two pads up to 2-3/8" (60mm). Raise or lower them so each is 3/4" to 1" (20mm to 25mm) above the frame and tighten **Locking Levers (D and E)** in Figure 6. Be sure the square pins are located in notches to prevent slippage. After tightening, be sure the **Locking Levers (D and E)** are not pointing downward because they may hit the table when the **Upper Clamps** descend. You can pull the handle free and rotate it. If a small frame is being joined, slide the rear **Clamp** out of position and close the **Valve (C)** in Figures 5 and 6 on top of the rear **Clamp**. Position the other **Clamp Pad** over the corner of the frame.

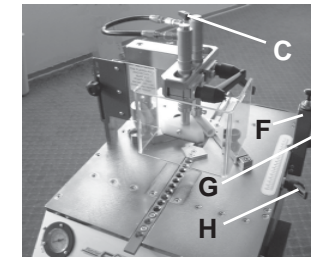

Figure 5

- Adjust the height of the **Plexiglas® Guard** about 1" (25mm) above the frame.
- Place one of the two moulding legs in position against the **Fence** and position the **Operating Handle (F)** so the first **Nail** will be inserted about 3/16" (5mm) from the rabbet. Loosen **Locking Lever (G)**, slide it against the **Operating Handle (F)** and tighten the **Locking Lever (G)**. This becomes the rear stop. Slide the **Operating Handle (F)** toward the front to locate the second **Nail** about 3/16" from the frame corner. Loosen and slide the **Locking Lever (H)** against the **Operating Handle (F)** and tighten the **Locking Lever (H)**. This becomes the front stop.

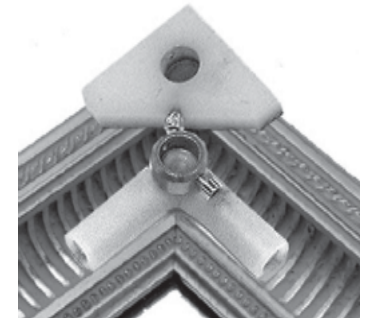

Figure 4

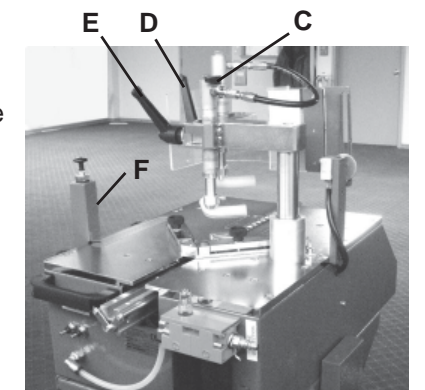

Figure 6