

Big Bench

- ⓐ ASSEMBLY INSTRUCTIONS
- ⓓ MONTAGEANLEITUNG
- ⓕ INSTRUCCIONES DE MONTAJE
- ⓔ INSTRUCTIONS DE MONTAGE
- ⓓ ISTRUZIONI PER L'ASSEMBLAGGIO

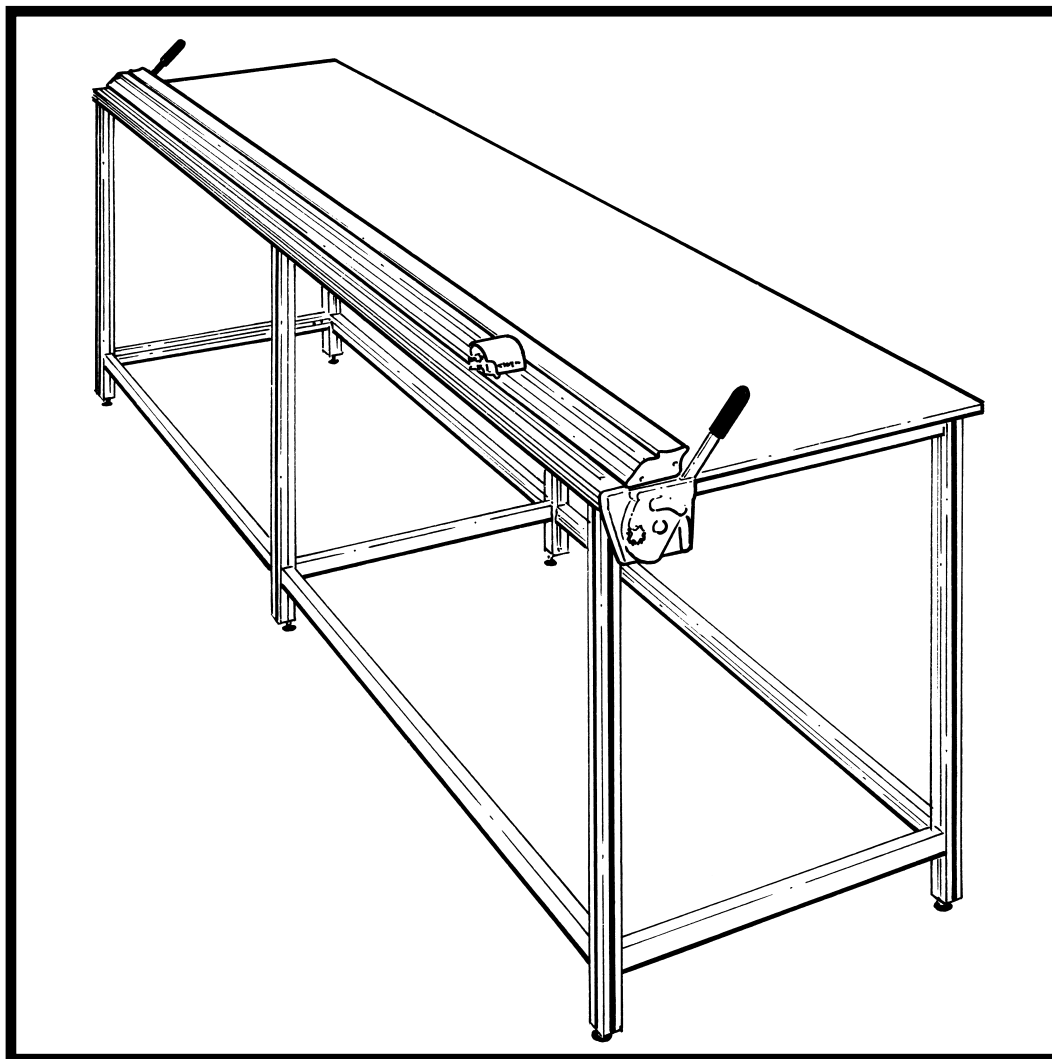

Thank you for choosing the Keencut Big Bench.
Every effort has been made to bring you a superbly
built product with the promise of many years of
good service.



Keencut - the world's finest cutting machines



Big Bench

GB ASSEMBLY INSTRUCTIONS

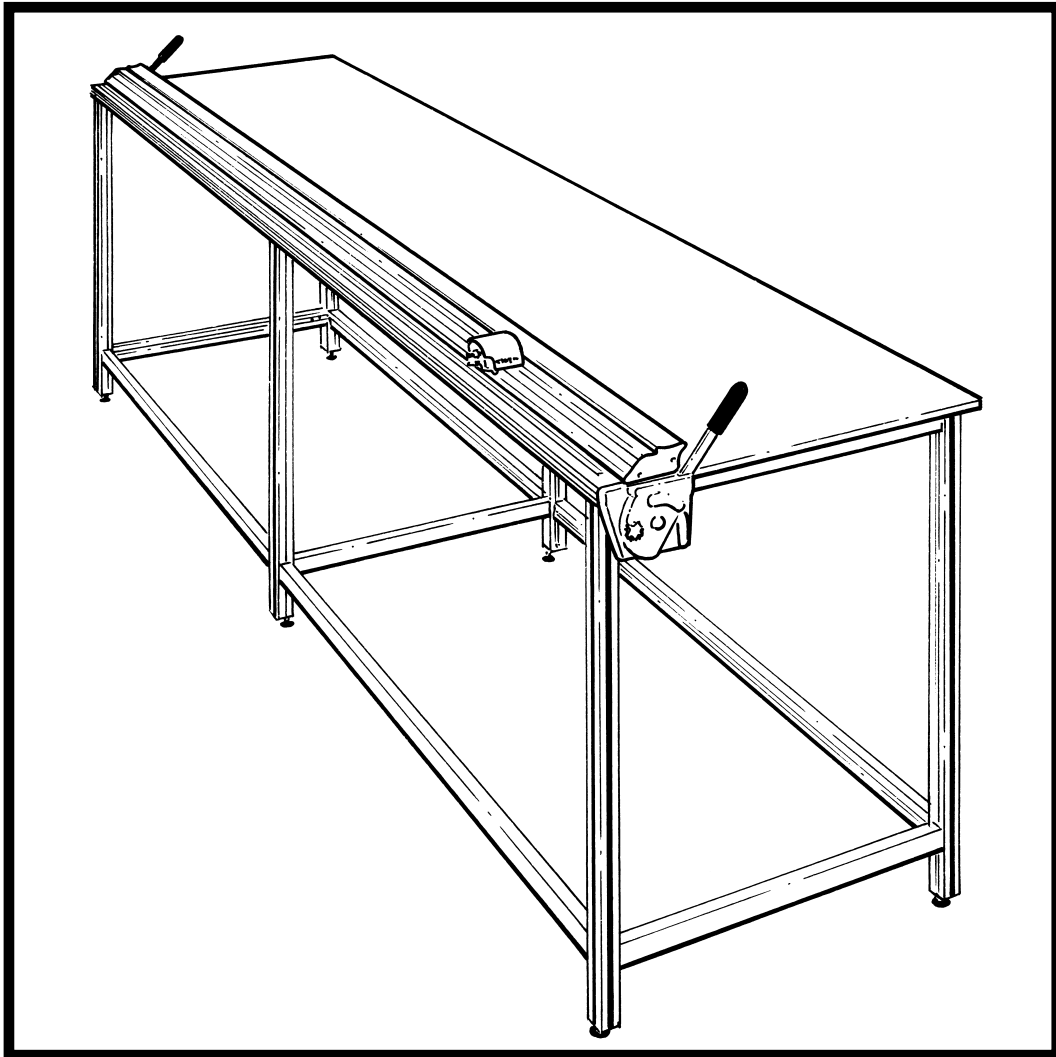

Thank you for choosing the Keencut Big Bench.
Every effort has been made to bring you a superbly
built product with the promise of many years of
good service.

Keencut - the world's finest cutting machines



You should have;

Packed in the Rectangular Boxes:

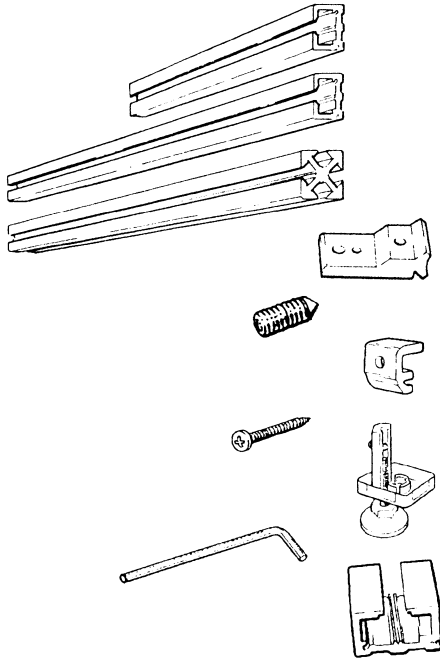

ITEM	QUANTITY FOR BIG BENCH			
	1.0,1.5	2.0,2.5,3.0	3.5,4.0,4.5	5.0
Short beam	4	6	8	10
Long beam	4	8	12	16
Leg	4	6	8	10
Joining Bracket	16	28	40	52
Grub Screw	48	84	120	156
Worktop Fixing	4	6	8	10
Long Screw	4	6	8	10
Height Adjuster	4	6	8	10
4mm Hexagon Wrench	1	1	1	1
Spacer	1	1	1	1

Packed in the TUBE:

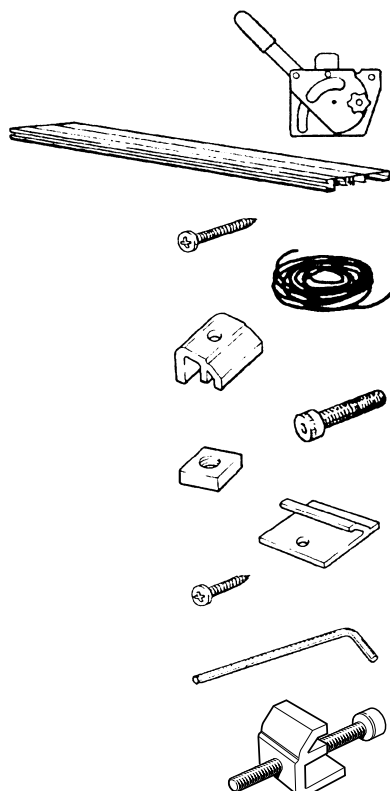

ITEM	QUANTITY FOR BIG BENCH			
	1.0,1.5	2.0,2.5,3.0	3.5,4.0,4.5	5.0
Lift & Hold (Left & Right)	(1,1)	(1,1)	(1,1)	(1,1)
Base Extrusion	1	1	1	1
Large Screw	6	6	6	6
Silicon Cord	1	1	1	1
Base Clamp	2	3	4	5
Cap Screw	2	3	4	5
Square Nut	2	3	4	5
Worktop Connector	2	4	6	8
Small Screw	2	4	6	8
5mm Hexagon Wrench	1	1	1	1
Levelling Bracket & Screw	2	4	6	8

The Order of assembly is important – the following diagrams are for quick reference only and are to enable the reader to familiarise themselves with the general assembly of the Big bench, the detailed assembly is described in 4 stages.

Stage 1

Fix the brackets to the legs.

The 1.0m & 1.5m Big bench have only 4 legs, please disregard the middle pair of legs.

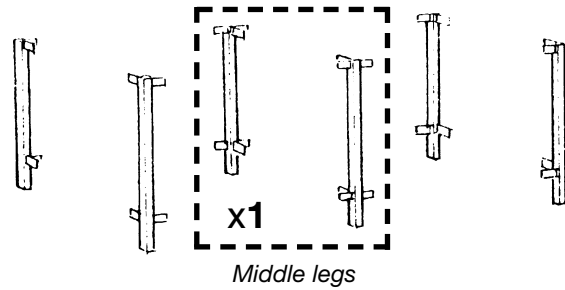
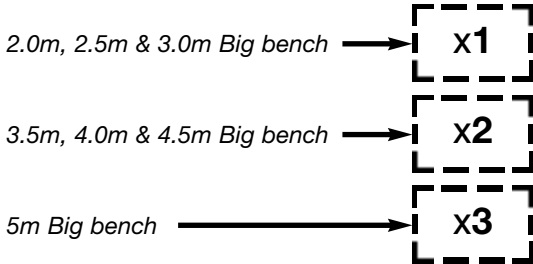

Stage 2

Construct the end frames.

Disregard the middle frame if you are building a 1.0m or 1.5m Big bench.

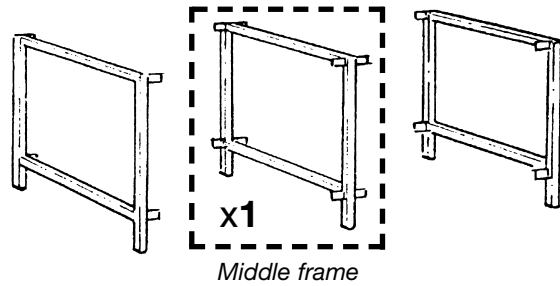
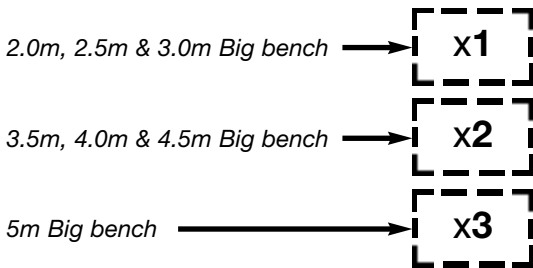

Stage 3

Join the end frames and cross beams to produce the bench.

1.0 & 1.5 Big bench

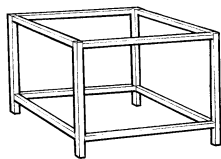

2.0, 2.5 & 3.0m Big bench

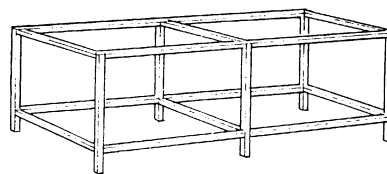

3.5, 4.0 & 4.5m Big bench

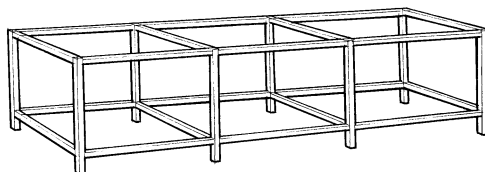

5m Big bench

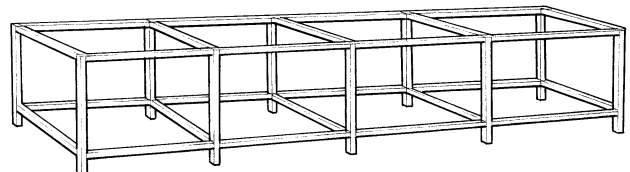

Stage 4

Attach the Javelin lift & hold mechanisms and base extrusion.

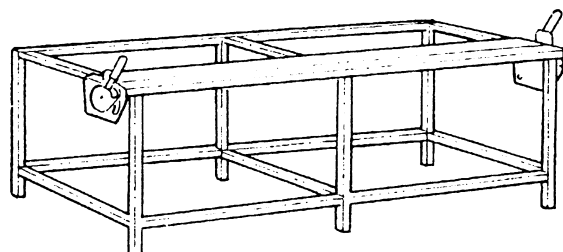

NOTE:
The following instructions will assume the Big bench has six legs (2.0, 2.5 or 3.0). If you are constructing a (1.0 or 1.5) Big bench please omit the **middle** frame.

Stage 1

- Put a grub screw backwards into each of the joining brackets – **do not** place screws in the other holes.

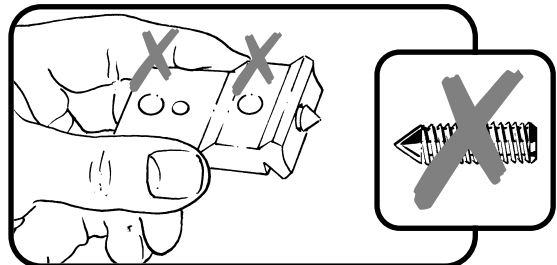
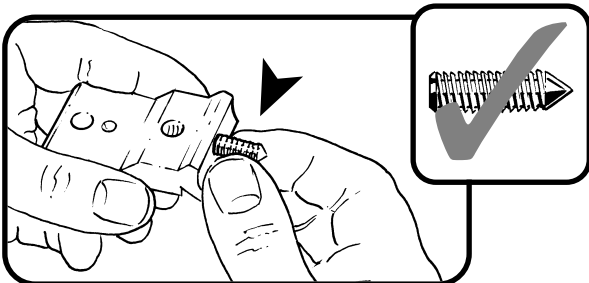

- Using the spacer, fit the brackets to the top of each leg as shown – ensure:

- The brackets are fitted the correct way round.
- The spacer is slightly above the top level of the leg, so when constructed the top level of the leg is not above the beam.
- The grub screws are tightened fully.

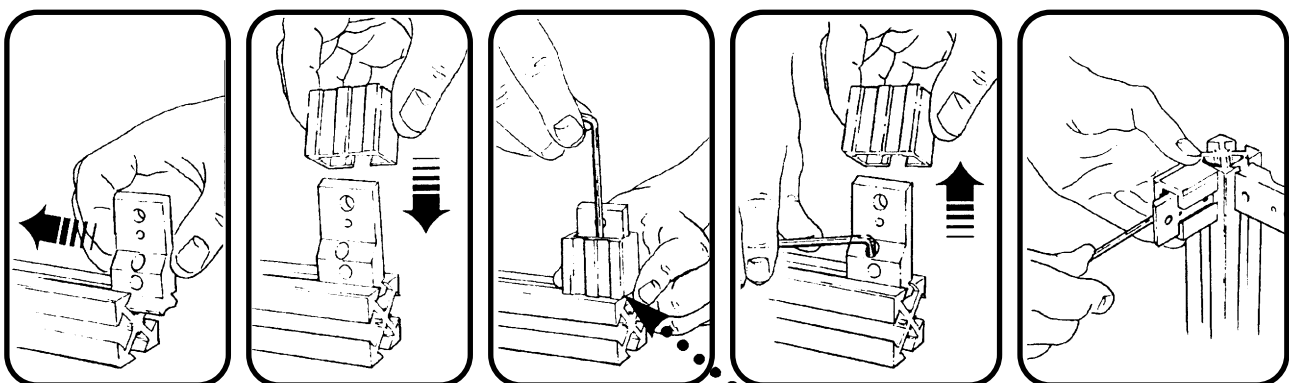
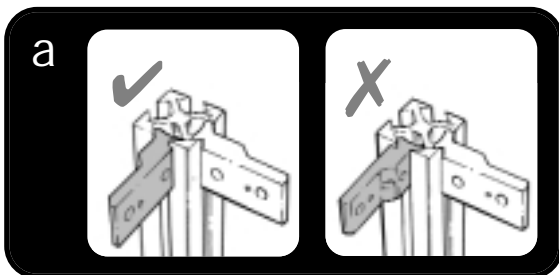
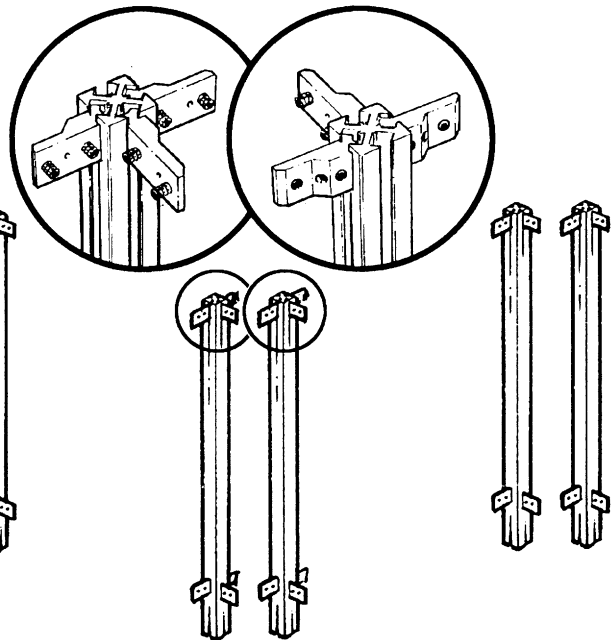

- Attach brackets to the bottom of the legs (and the same way round as shown above), using a tape measure or spacer to position them to suit your requirements.



- Put grub screws in each of the two large holes of the bracket, only screw them in 2 or 3 turns.

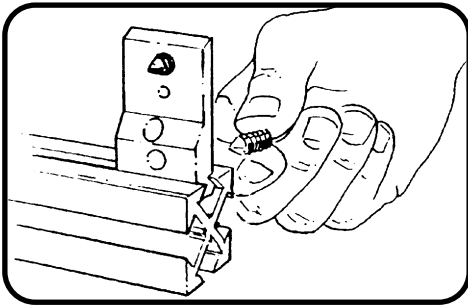

- Fix the height adjusters into the bottom of each leg. Position the adjuster in one of the internal grooves of the leg (ie. the same groove the brackets are fitted).

Position the bottom of the aluminium bracket level with the bottom of the leg and tighten the grub screw fully.

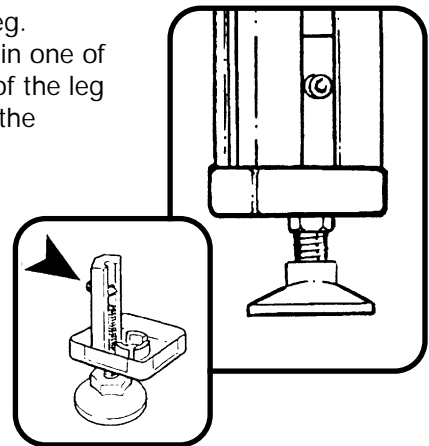

Stage 2

- Fit the two short beams between each pair of leg assemblies ensuring the small groove in the beam is uppermost.
- Pulling the two legs together (to close any gaps between the end of the beam and the legs) tighten all the grub screws.

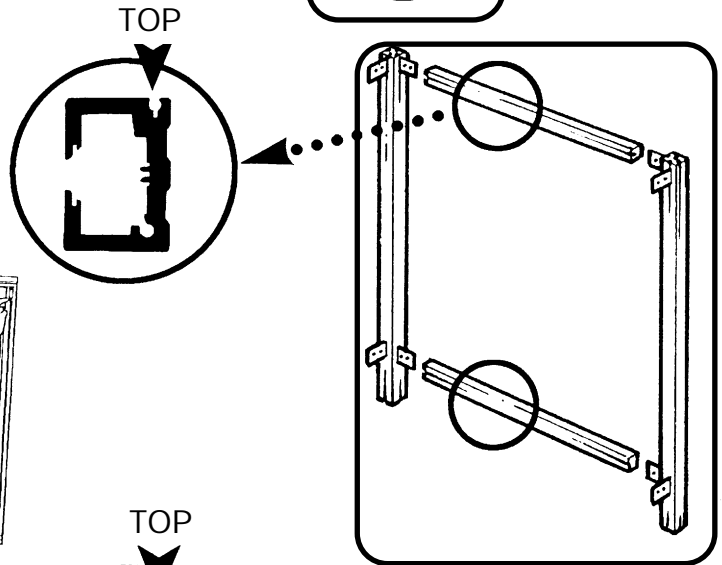
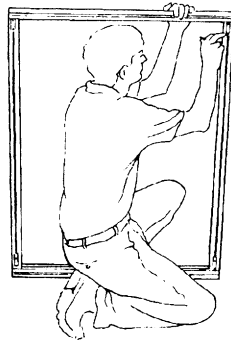

Stage 3

- Place one end frame on the floor with the brackets pointing upwards and position a long beam over each bracket (again ensure the small groove in the beam will be uppermost).
- Place either:
the other end frame (if you are constructing a 1.0m or 1.5m big bench)
or
The centre frame (if you are constructing a 2.0m, 2.5m or 3.0m Big bench)

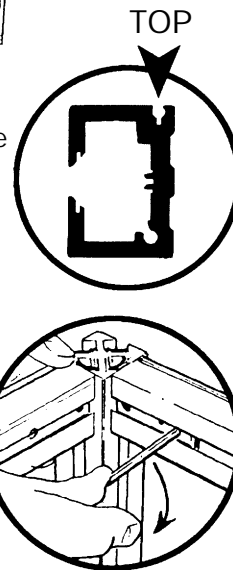

over the beams and tighten the grub screws ensuring there are no gaps between the beam ends and the legs.

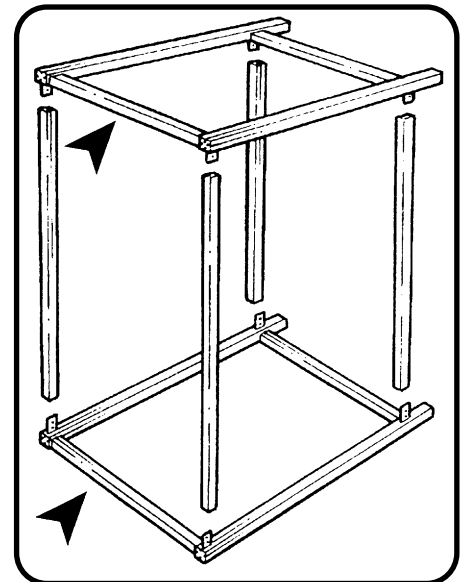

- 2.0m, 2.5m or 3.0m Big bench only**

Stand the frame onto its feet and position the remaining long beams between the frame and the remaining end frame, tighten all the grub screws again ensuring there are no gaps between the beam ends and the legs.

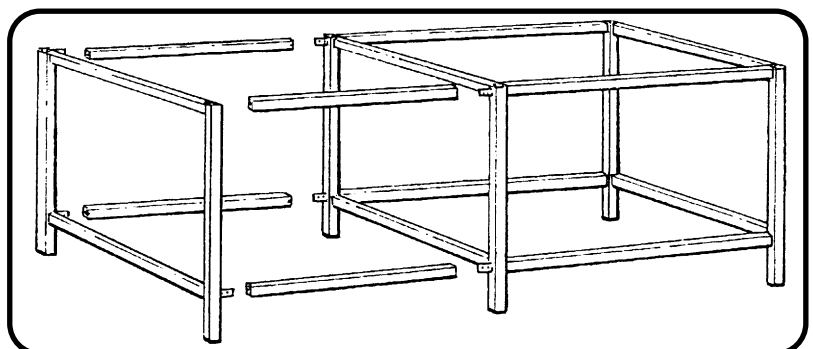

Stage 4

1. Place the base extrusion on the edge of the bench so the lip hangs over the front edge of the legs. Slide the square nuts into the recess as shown and place one near to each leg. Slide the workshop fixing plates into their groove and position them at approximately equal spaces along the base extrusion.

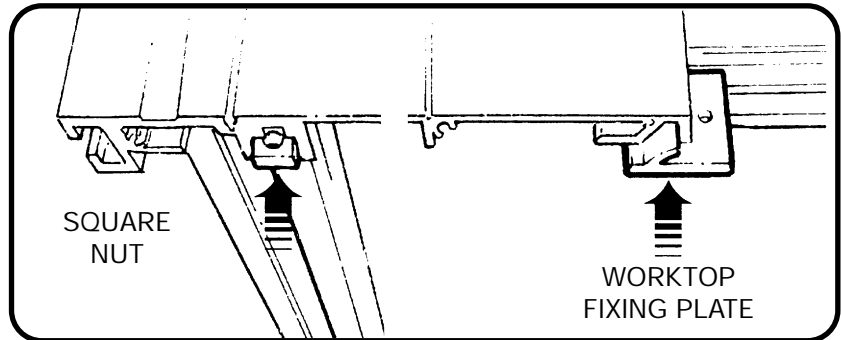
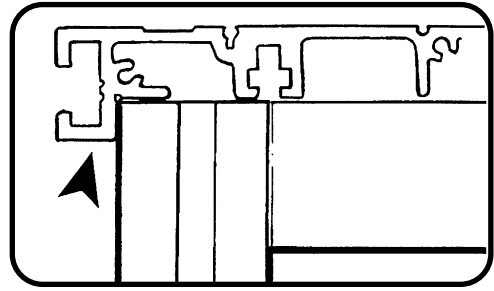

2. Using the 5mm hexagon wrench fix the base extrusion in place on the bench with the base clamps and cap screws.

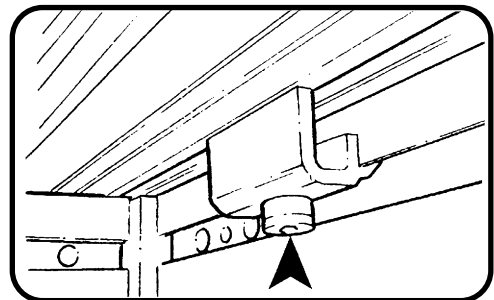

View from underneath

3. Fix the lift & hold mechanisms to each end of the base extrusion with three self tapping large screws on each end, **do not** at this stage tighten the screws fully.

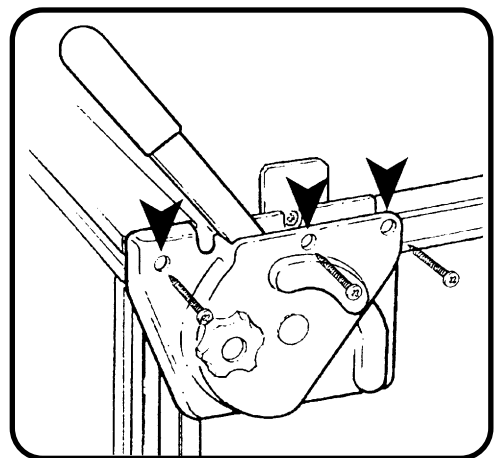

Stage 4 – cont'd

4. Fix the Worktop in place using
 - a) The large workshop fixing and large screws as shown.
 - b) the small screws to fix the worktop fixing plates.

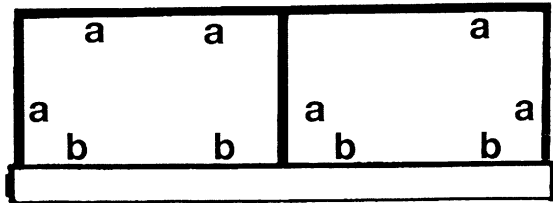
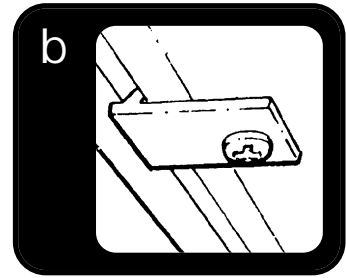
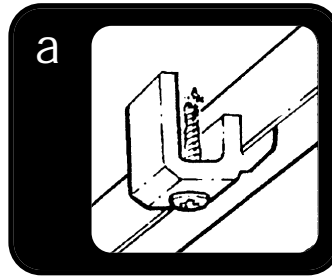

Plan View

Position brackets approximately as shown

5. Position the Javelin cutter onto the two lift & hold mechanisms by sliding the tongue into the slot inside the end caps of the Javelin.

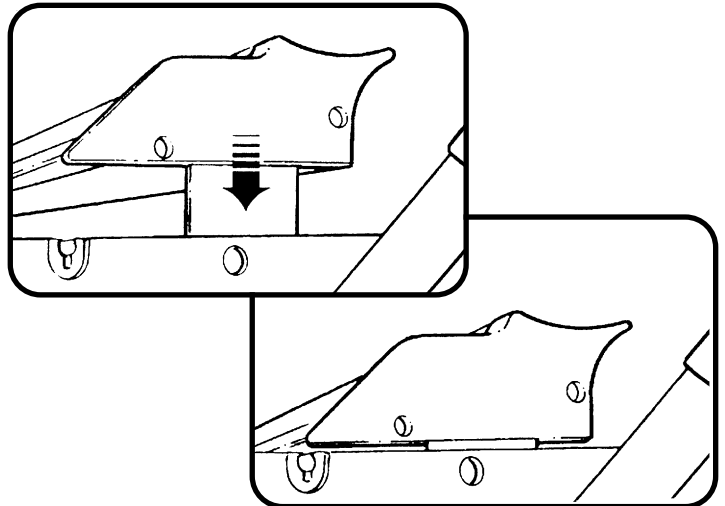

NOTE:

The friction knob on each mechanisms can be adjusted to hold the Javelin at any height which makes accurate lining up easier when in use.

6. Move the cutting head to one end of the Javelin and depress the blade, adjust the position of the lift & hold mechanism so the blade runs centrally in the slot on the base extrusion, tighten the three screws to fasten the lift & hold.

Repeat for the other end.

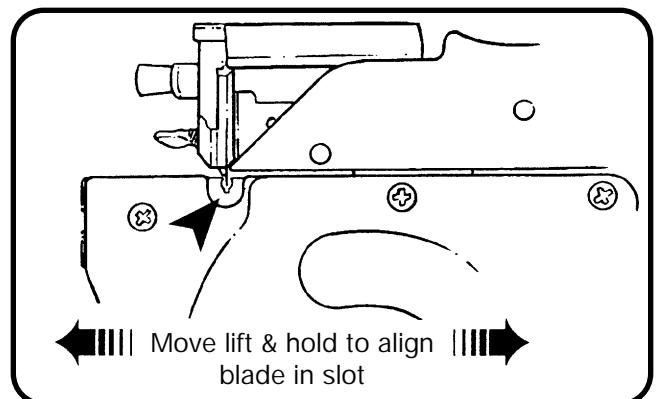

7. Position the bench in place and using an accurate spirit level adjust the feet to ensure the top surface of the table is flat. If the table is not flat, particularly along it's length, there may be difficulty in holding the workpiece in place along the full cut length.

8. If a thin film or paper is being cut check that the material can be gripped along the full length of the bench. Pass a small piece of the material about 25cm (10") wide under the cutter and ensure it is held in place, carry this out along its full length.

Should the cutter not grip adjacent to a bench leg, adjust the foot to slightly raise that part of the bench and test again.

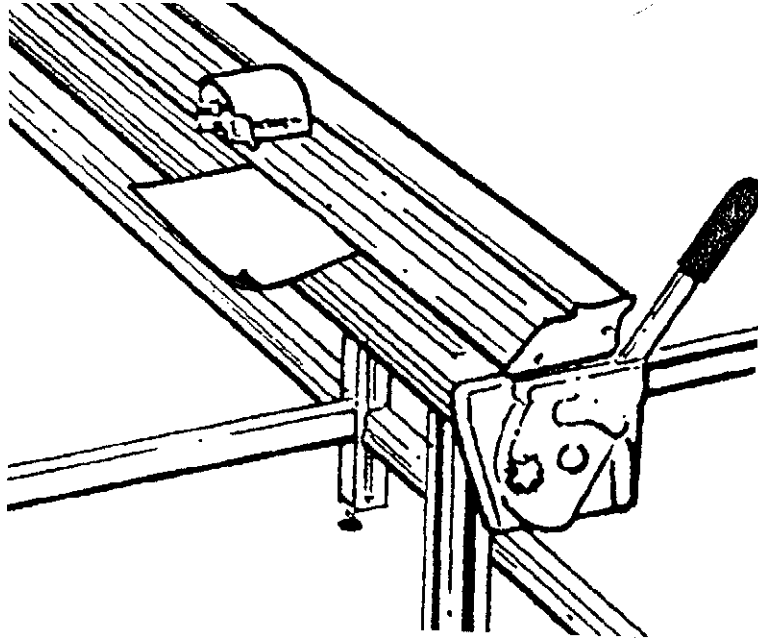

Should the paper not be gripped by the cutter bar between the legs, place a levelling bracket and screw in the beam on the underside of the base extrusion. Position it in the middle of the area that is not clamping and tighten the screw until the paper is clamped efficiently. Check the whole cutter bar is clamping, add more levelling brackets and adjust if necessary.

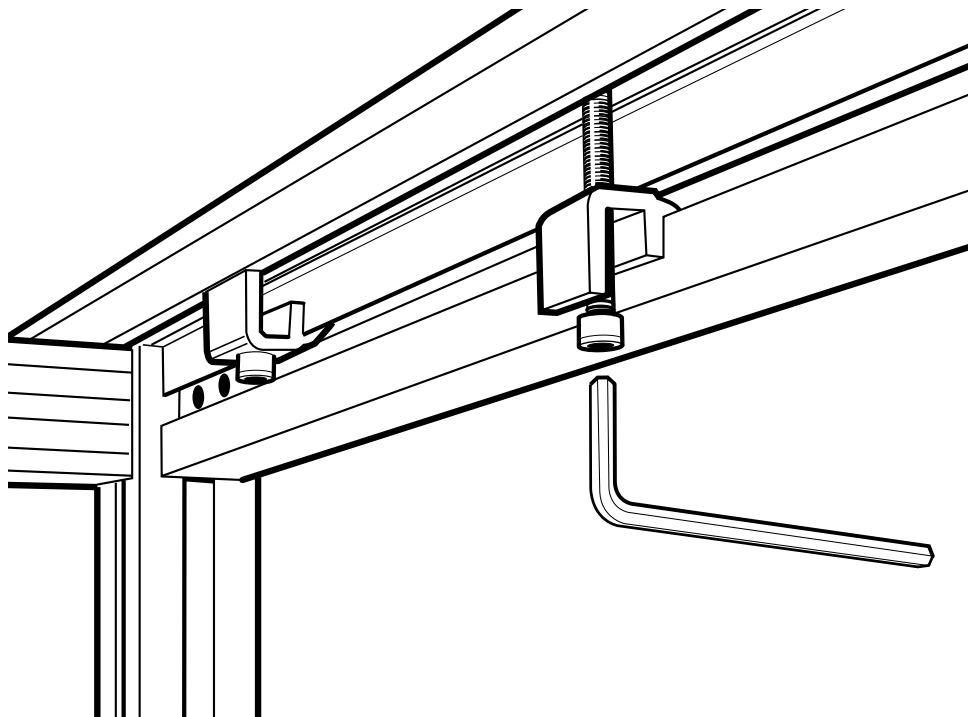

Big Bench

ⓓ MONTAGEANLEITUNG

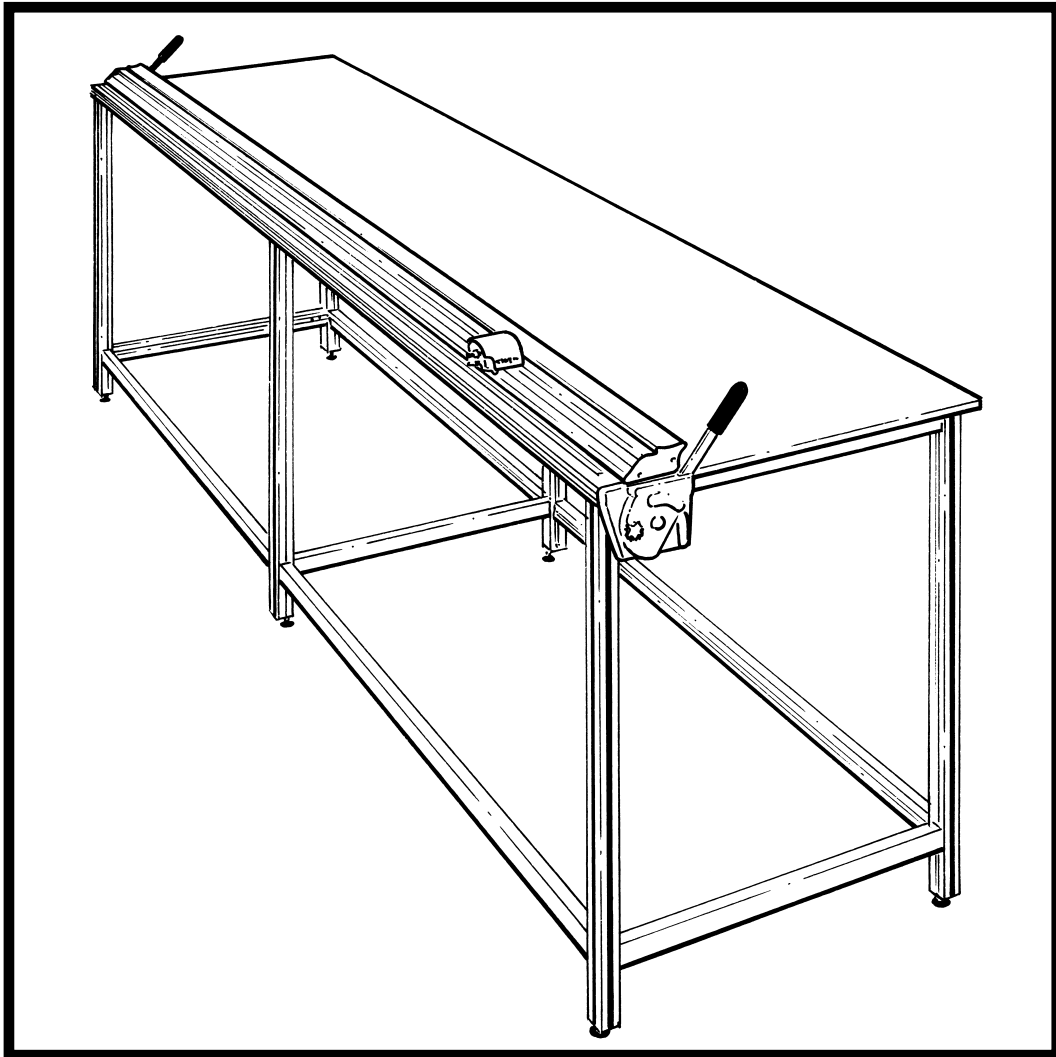

Wir gratulieren Ihnen zum Kauf Ihrer "Big Bench" von Keencut! Es wurden alle Anstrengungen gemacht, Ihnen ein erstklassig gebautes Produkt zu liefern, das Ihnen verspricht, über viele Jahre hinweg gute Dienste zu erweisen.

Keencut - the world's finest cutting machines



Es sollte Folgendes vorhanden sein:

In Kisten verpackt:

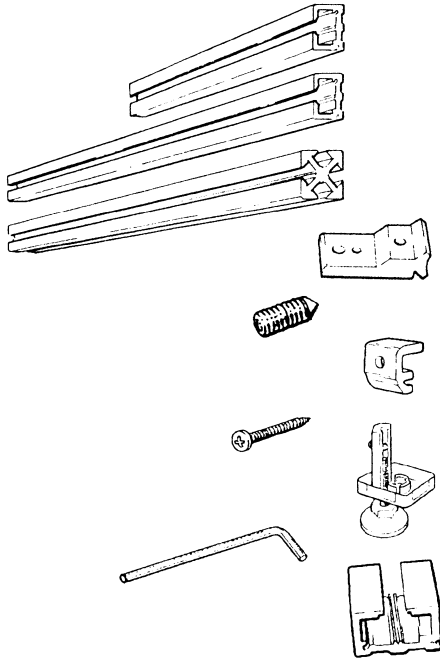

	Menge gilt für eine "Big Bench"			
	1.0,1.5	2.0,2.5,3.0	3.5,4.0,4.5	5.0
Kurzer Balken	4	6	8	10
Langer Balken	4	8	12	16
Stützbein	4	6	8	10
Verbindungsklammer	16	28	40	52
Gewindestift	48	84	120	156
Arbeitstischbefestigung	4	6	8	10
Lange Schraube	4	6	8	10
Höheneinsteller	4	6	8	10
4mm großer Sechskantschlüssel	1	1	1	1
Abstandsstück	1	1	1	1

In Röhre verpackt:

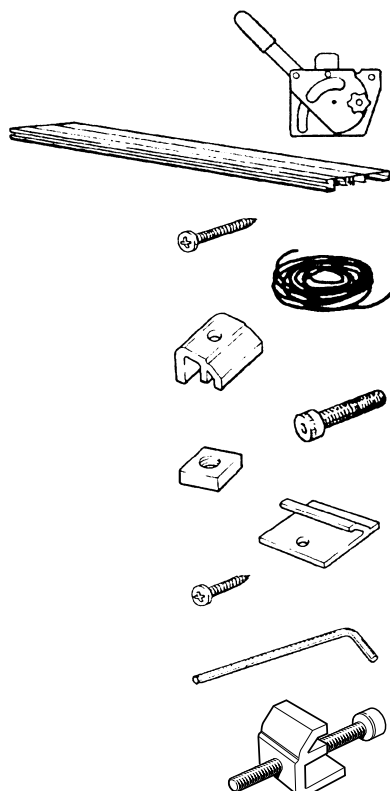

	Menge gilt für eine "Big Bench"			
	1.0,1.5	2.0,2.5,3.0	3.5,4.0,4.5	5.0
Hebe- und Haltemechanismus	(1,1)	(1,1)	(1,1)	(1,1)
Bodenstrangprelfteil	1	1	1	1
Große Schraube	6	6	6	6
Silikonschnur	1	1	1	1
Bodenklemmvorrichtung	2	3	4	5
Kopfschraube	2	3	4	5
Vierkantmutter	2	3	4	5
Arbeitstischbefestigung	2	4	6	8
Kleine Schraube	2	4	6	8
5mm großer Sechskantschlüssel	1	1	1	1
	2	4	6	8

Die Reihenfolge der Montage ist auflerordentlich wichtig - die nachfolgenden Diagramme sollen dem Leser jedoch nur zur Bezugnahme und zur Vertrautmachung mit der Montage der "Big Bench" generell dienen. Die Montage im Detail läßt sich anhand von 4 Abschnitten beschreiben.

Montageabschnitt 1

Die Klammern an den Beinen befestigen.

Die 1,0 m und die 1,5 m große "Big Bench" verfügen nur über 4 Beine, daher kann das mittlere Beinpaar außer Acht gelassen werden.

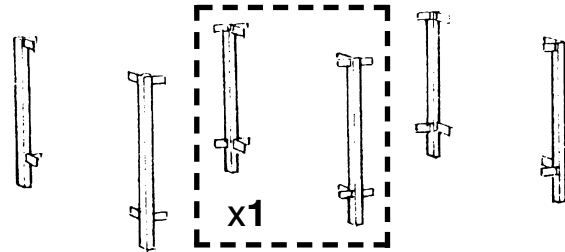
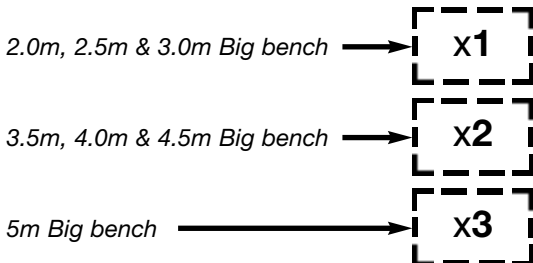

Montageabschnitt 2

Die Endrahmen zusammenbauen.

Der Mittelrahmen ist bei der Montage einer 1,0 m oder 1,5 m großen "Big Bench" nicht zu berücksichtigen.

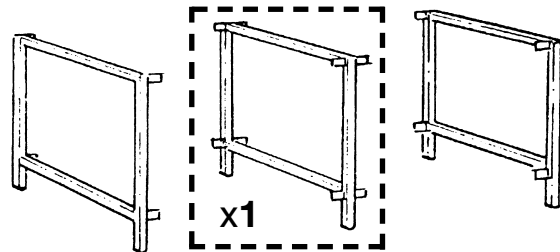
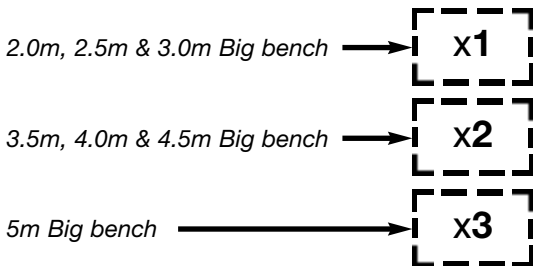

Montageabschnitt 3

Die Endrahmen zusammenfügen und die Balken überkreuzen, so dass eine Werkbank entsteht.

1.0 & 1.5 Big bench

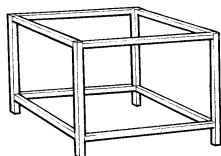

2.0, 2.5 & 3.0m Big bench

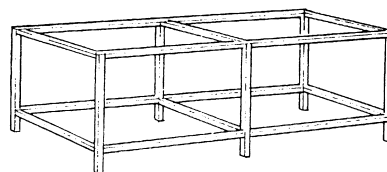

3.5, 4.0 & 4.5m Big bench

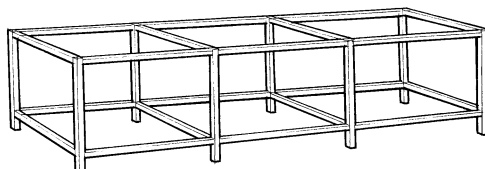

5m Big bench

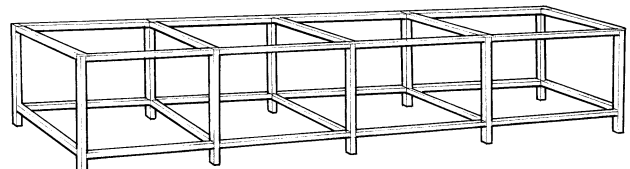

Montageabschnitt 4

Hebe- und Haltemechanismen und Bodenstrangpreßteil des "Javelin" befestigen.

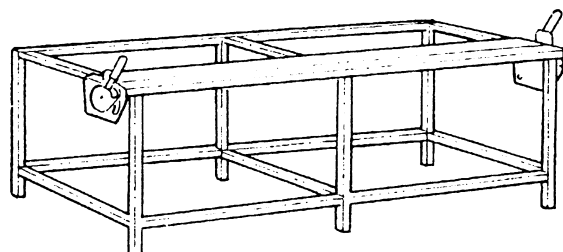

Hinweis:

Die folgenden Anweisungen setzen voraus, dass die "Big Bench" über sechs Beine (bei Modellen 2.0, 2.5 und 3.0) verfügt. Falls Sie eine 1,0 m oder 1,5 m große "Big Bench" zusammenbauen, lassen Sie bitte den Mittelrahmen außer Acht.

Montageabschnitt 1

1. Einen Gewindestift rückwärts in jede der Verbindungsklammern einsetzen - keine Schrauben in die anderen Löcher einsetzen.

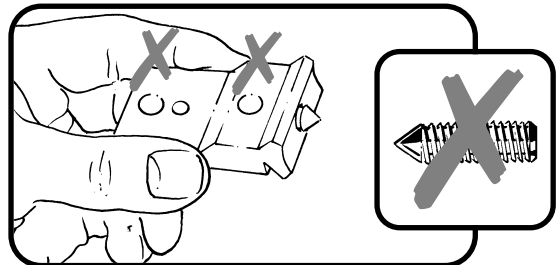
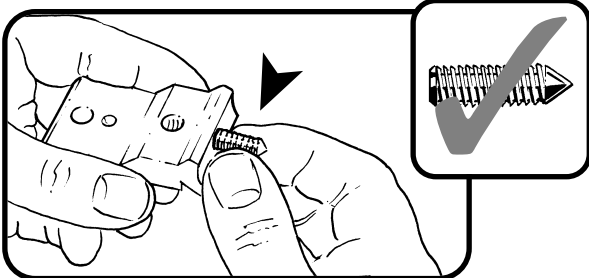

2. Unter Verwendung des Abstandsstücks die Befestigungsklammern, wie dargestellt, oben an jedem Bein anbringen und dafür sorgen, dass:
 - a). die Befestigungsklammern richtig herum angebracht werden
 - b). sich das Abstandsstück etwas oberhalb der Oberkante des Beins befindet, so dass sich beim Zusammenbau die Oberkante des Beins nicht oberhalb des Balkens befindet.
 - c). die Gewindestifte fest angezogen werden.

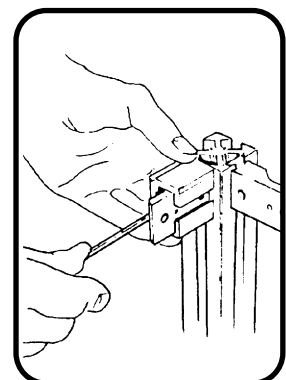
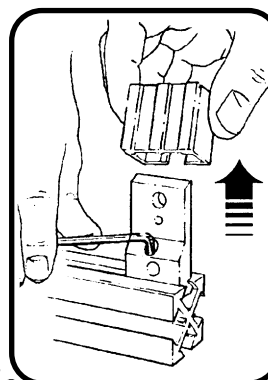
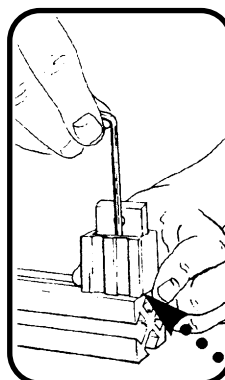
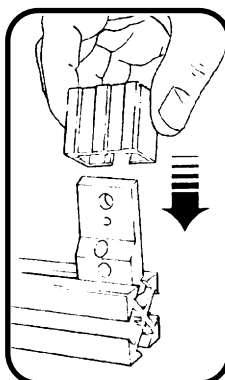
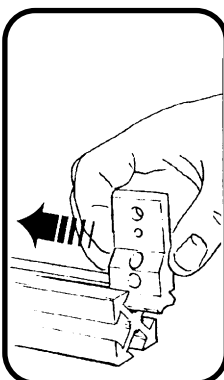
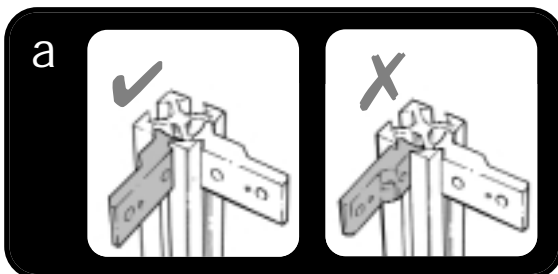
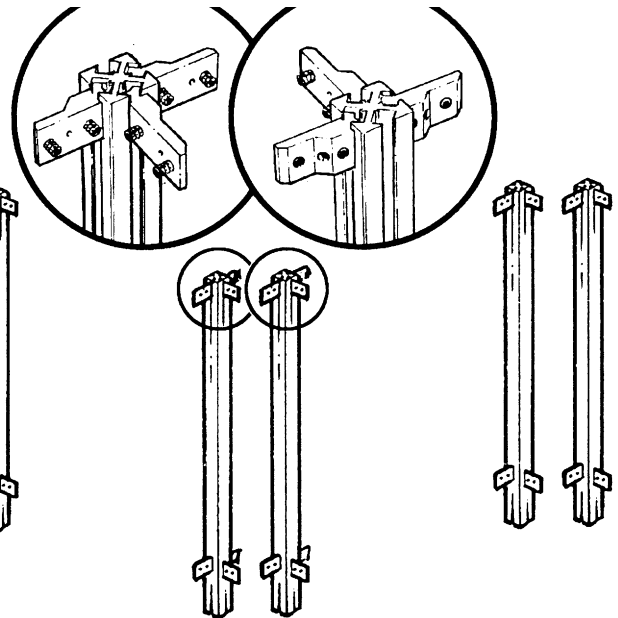

3. Unter Verwendung eines Messbandes oder eines Abstandsstücks zur Positionierung gemäß Ihrer Erfordernisse die Befestigungsklammern unten an den Beinen anbringen (und zwar richtig herum, wie oben dargestellt).



4. Die Gewindestifte in jedes der beiden großen Löcher in der Befestigungsklammer einsetzen und um lediglich 2 oder 3 Umdrehungen anziehen.

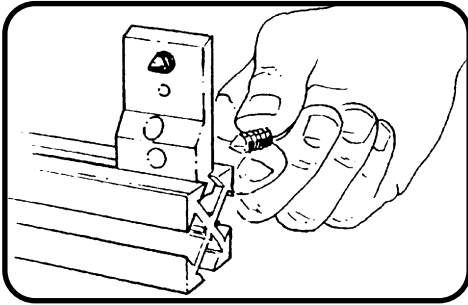

5. Die Höhenversteller unten an jedem Bein befestigen. Die Höhenversteller in einer der Innennuten des Beins positionieren (d.h. in derselben Nut, an der die Befestigungsklammern montiert wurden).

Die Unterkante der Aluminiumklammer auf gleicher Höhe mit der Unterkante des Beins positionieren und den Gewindestift nun fest anziehen.

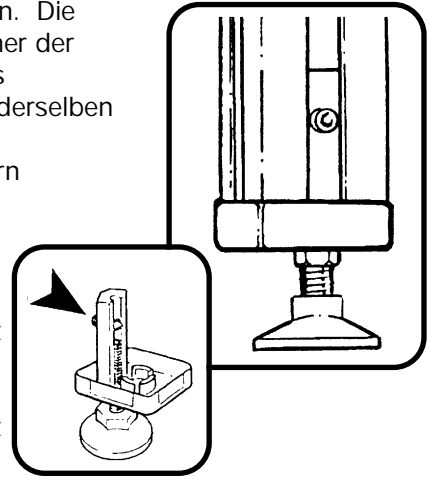

Montageabschnitt 2

1. Die beiden kurzen Balken zwischen jedem Beinpaar befestigen und dafür sorgen, dass sich die kleine Nut im Balken oben befindet.
2. Die beiden Beine eng zusammenhalten (um etwaige Abstände zwischen dem Ende des Balkens und der Beine zu schließen) und alle Gewindestifte fest anziehen.

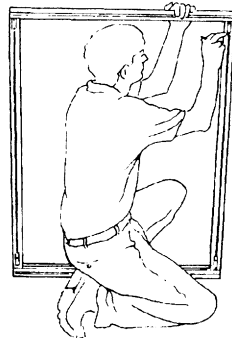

ARBEITSTISCH

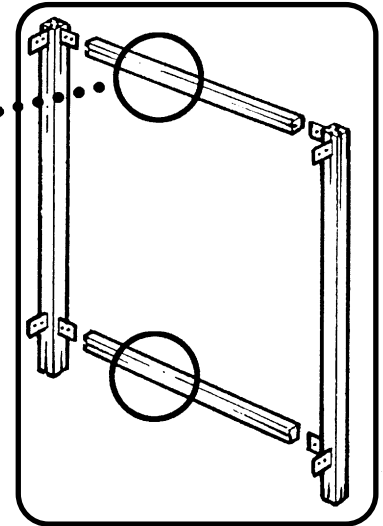
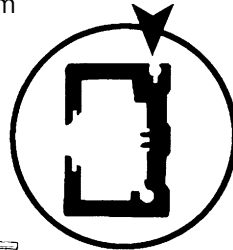

ARBEITSTISCH

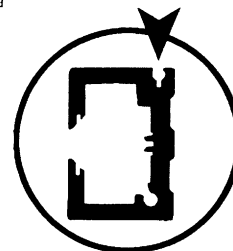

Montageabschnitt 3

1. Das eine Ende des Rahmens auf den Boden legen, wobei die Befestigungsklammern nach oben zeigen müssen, und einen langen Balken über jede der Befestigungsklammern positionieren (dabei ist wiederum darauf zu achten, dass sich die kleine Nut im Balken ganz oben befindet).
2. Entweder:
 das andere Ende des Rahmens (falls Sie eine 1,0 oder 1,5 m große Big Bench zusammenbauen)
 oder den Mittelrahmen (falls Sie eine 2,0, 2,5 oder 3,0 m große Big Bench zusammenbauen) über den Balken positionieren und die Gewindestifte anziehen, wobei darauf zu achten ist, dass zwischen den Balkenenden und den Beinen keine Zwischenräume vorhanden sind.

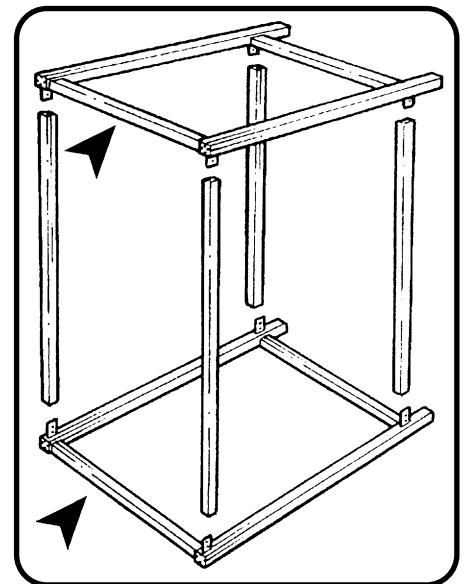
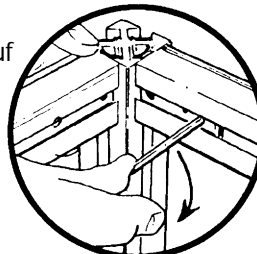

3. Nur bei 2,0, 2,5 oder 3,0 m großer Big Bench auszuführen:

Den Rahmen aufstellen und die verbleibenden langen Balken zwischen dem Rahmen und dem verbleibenden Endrahmen positionieren, alle Gewindestifte fest anziehen und dabei dafür sorgen, dass keine Zwischenräume zwischen den Balkenenden und den Beinen vorhanden sind.

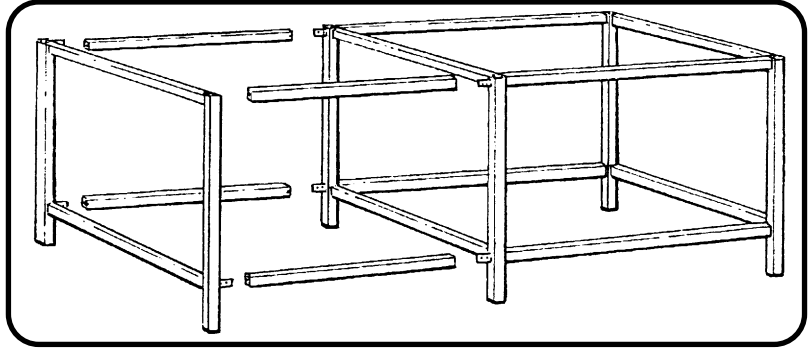

Montageabschnitt 4

1. Das Bodenstrangpreßteil an der Arbeitstischkante placieren, so dass die Lippe über die Vorderkante der Beine herausragt. Die Vierkantsmuttern, wie dargestellt, in die Aussparung einsetzen und eine nahe jedes Beins placieren. Die Befestigungsplatten des Arbeitstisches in ihre Nuten schieben und in ungefähr gleichen Abständen entlang des Bodenstrangpreßteils positionieren.

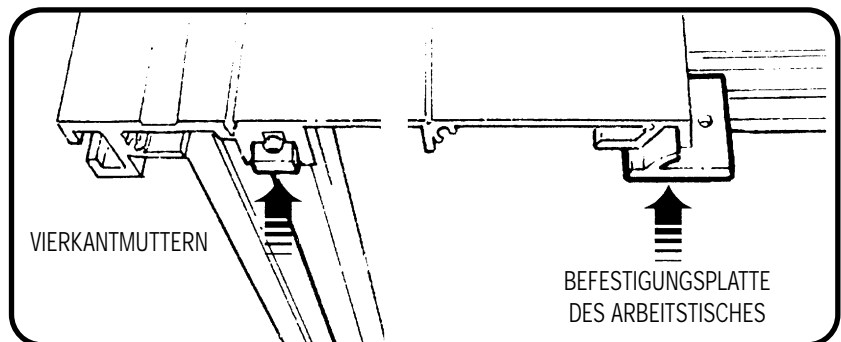
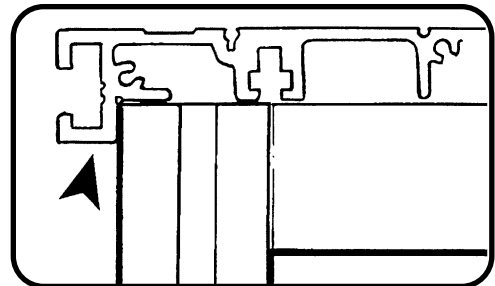

2. Unter Verwendung eines 5 mm großen Sechskantschlüssels das Bodenstrangpreßteil mit den Bodenklammern und Kopfschrauben an der Werkbank befestigen.

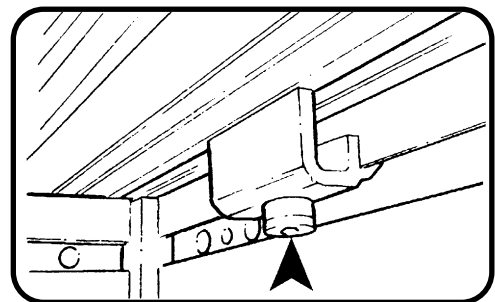

Ansicht von unten

3. Die Hebe- und Haltemechanismen mit jeweils drei großen Schneidschrauben an beiden Enden des Bodenstrangpreßteils befestigen, die Schrauben aber zu diesem Zeitpunkt noch nicht voll anziehen.

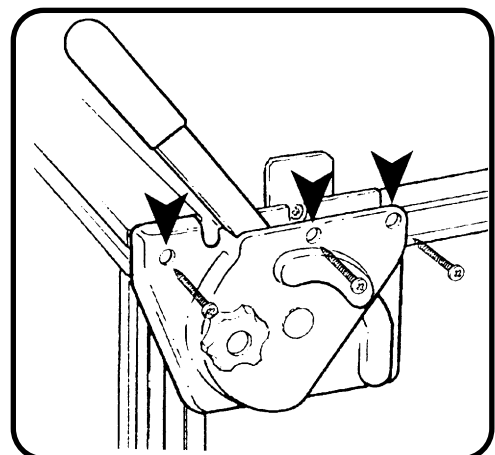

Montageabschnitt 4

4. Werkbank einrichten unter Verwendung von:
- der großen Werkbankbefestigung und den großen Schrauben, wie dargestellt, und
 - den kleinen Schrauben zur Befestigung der Befestigungsplatten der Werkbank.

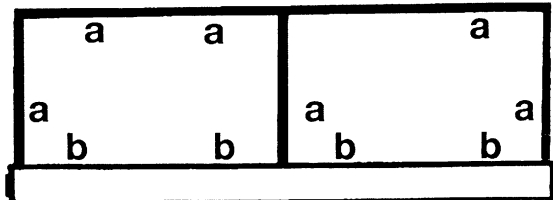
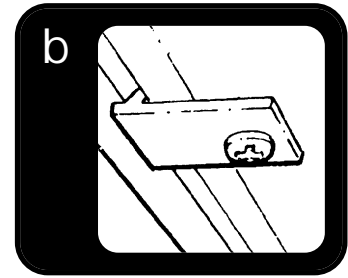
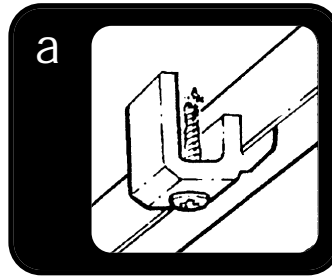

Planansicht

Wie links dargestellt, die Klammern in ähnlicher Stellung positionieren.

5. Das Javelin-Schneidergerät auf den zwei Hebe- und Haltemechanismen positionieren, indem die Führungsfeder in den Schlitz innen in den Endkappen des Javelin eingeführt wird.

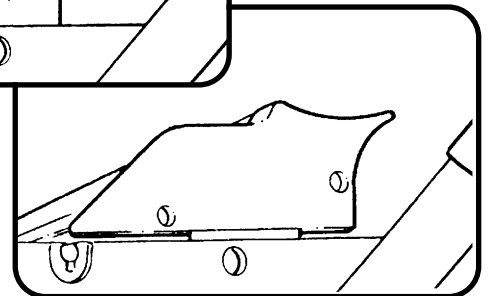
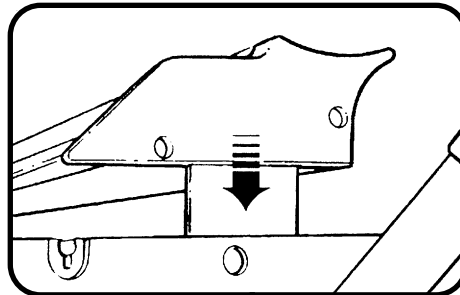
**HINWEIS:**

Der Reibhaken an jedem Mechanismus ist höhenverstellbar, damit der Javelin auf jede beliebige Höhe, die bei der Verwendung korrektes Ausrichten vereinfacht, eingestellt werden kann.

6. Den Schneidkopf an das eine Ende des Javelin bewegen und die Klinge herunterdrücken; die Stellung des Hebe- und Haltemechanismus so einstellen, dass die Klinge in der Mitte des Schlitzes im Bodenstrangpreßteil entlangläuft; die drei Schrauben zur Befestigung des Hebe- und Haltemechanismus fest anziehen. Diesen Vorgang für das andere Ende wiederholen.

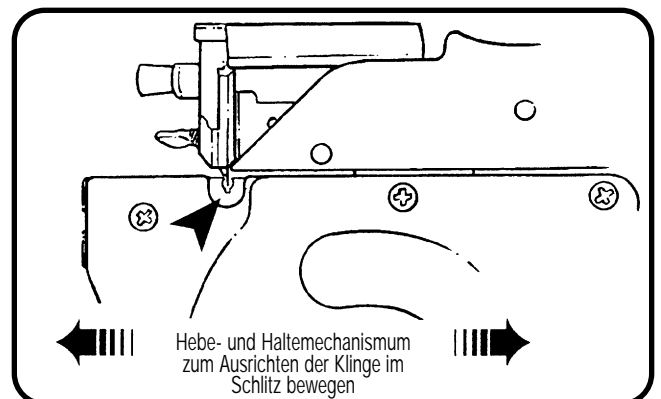

7. Die Bench richtig positionieren und unter Verwendung einer korrekt geeichten Wasserwaage die Füße einstellen, um zu gewährleisten, dass die Oberfläche des Tisches eben ist. Falls der Tisch nicht eben ist, insbesondere entlang seiner gesamten Länge, kann es zu Schwierigkeiten beim Halten des Werkstücks entlang der vollen Schneidlänge kommen.

8. Falls dünne Folien oder Papier geschnitten werden, ist darauf zu achten, dass das Material entlang der vollen Länge des Tisches gehalten werden kann. Ein kleines Stück des jeweiligen Materials rund 25 cm (10") weit unter das Schneidgerät legen und dafür sorgen, dass es gut fest gehalten wird. Dieser Vorgang ist entlang der vollen Länge auszuführen.

Sollte das Schneidgerät neben einem Tischbein nicht greifen, ist der Fuss zu verstellen, um diesen Teil des Tisches leicht zu erhöhen, anschließend erneut überprüfen.

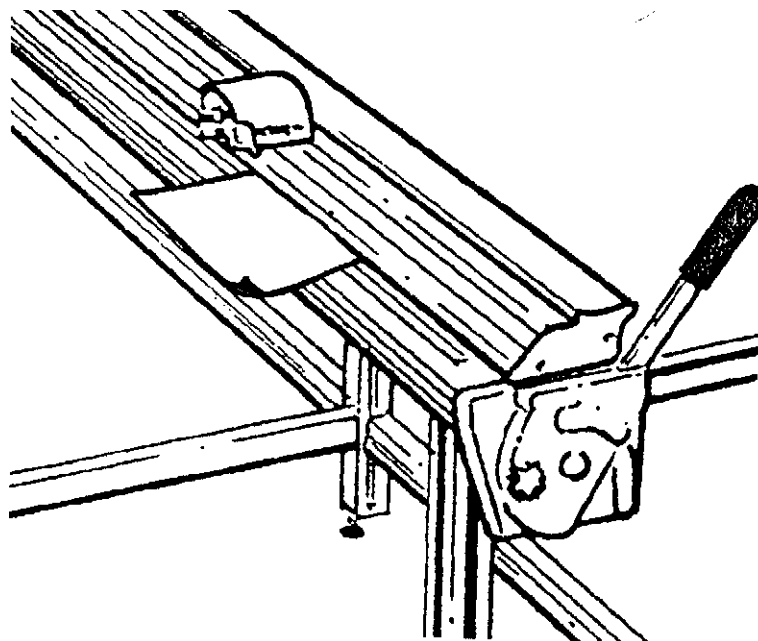

Falls das Stangenschneidgerät zwischen den Standbeinen das Papier nicht richtig greifen sollte, setzen Sie eine Nivellierklammer mit Schraube in den Träger auf der Unterseite des Strangpressunterteils ein. Richten Sie diese mittig in dem Bereich aus, der nicht richtig greift, und ziehen Sie die Schraube fest, bis das Papier gut festgehalten wird.

Überprüfen Sie, ob das gesamte Stangenschneidgerät gut greift, setzen Sie gegebenenfalls weitere Nivellierklammern ein und richten diese aus.

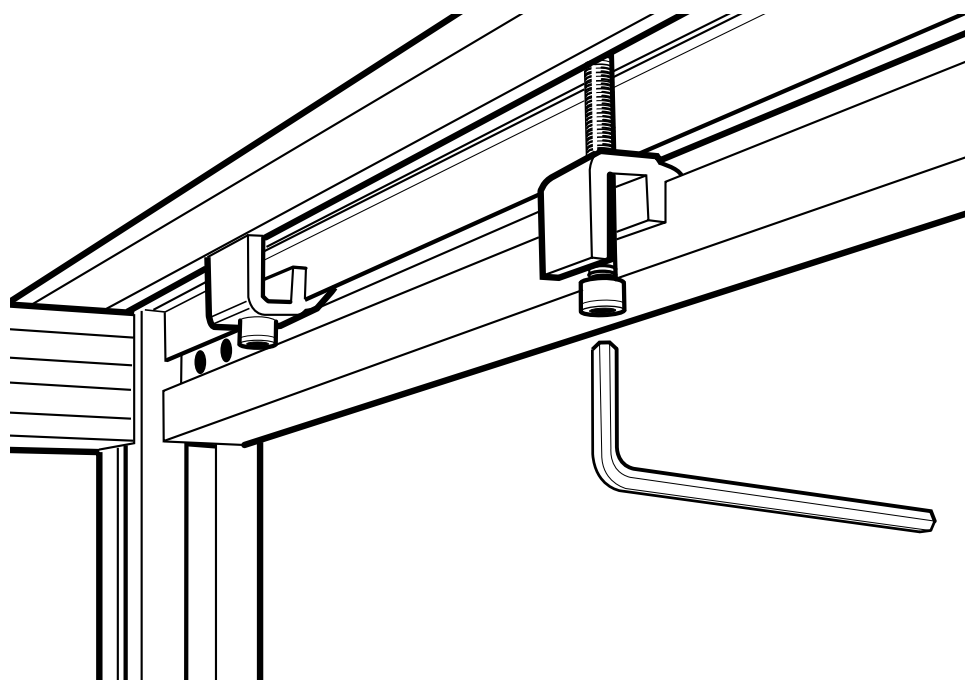

Big Bench

Ⓔ INSTRUCTIONS DE MONTAGE

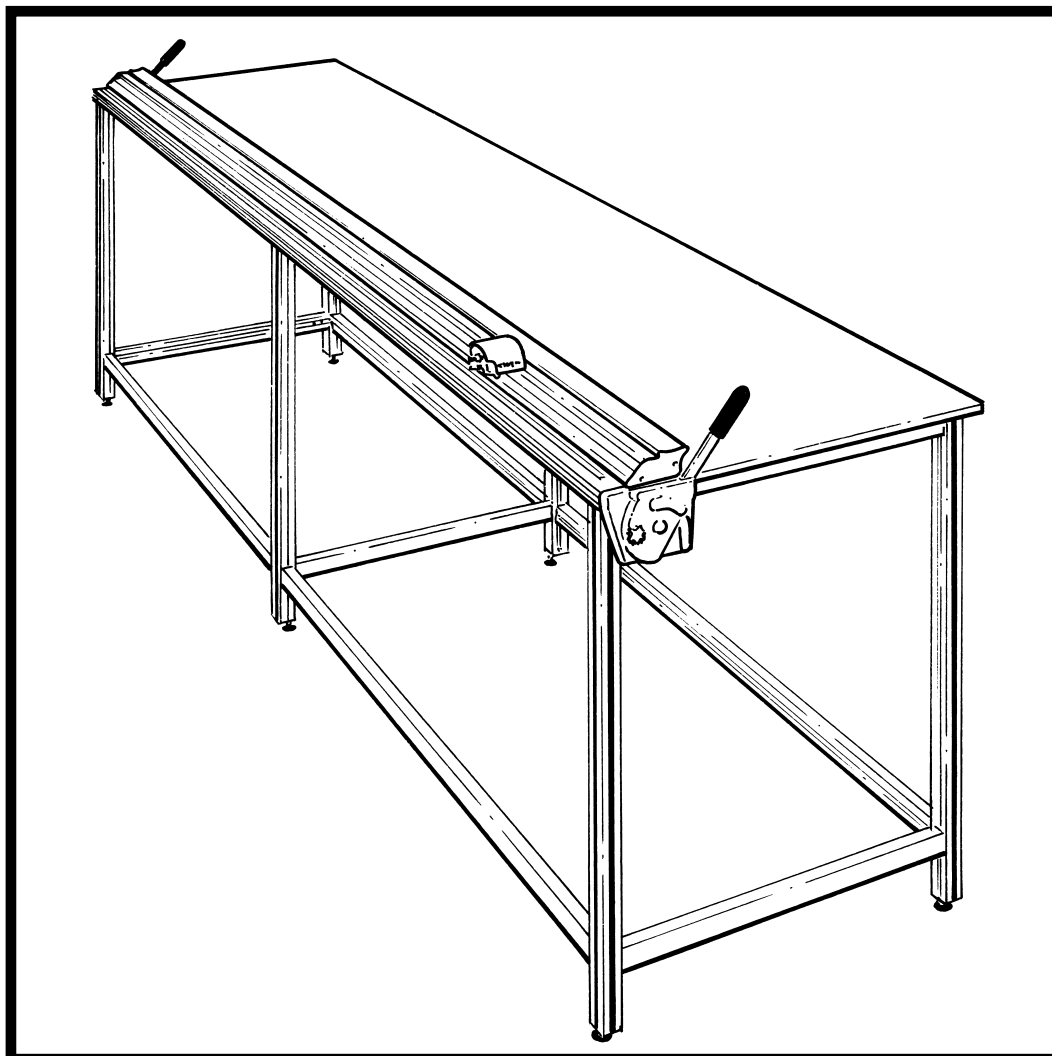

Agradecemos la confianza que ha depositado en Keencut al adquirir nuestro sistema "Big Bench". Hemos realizado todo esfuerzo posible a fin de ofrecerle un producto de extraordinaria fabricación y la promesa de muchos años de excelente servicio.

Keencut - the world's finest cutting machines



Debe tener;

Empaquetado en las cajas rectangulares:

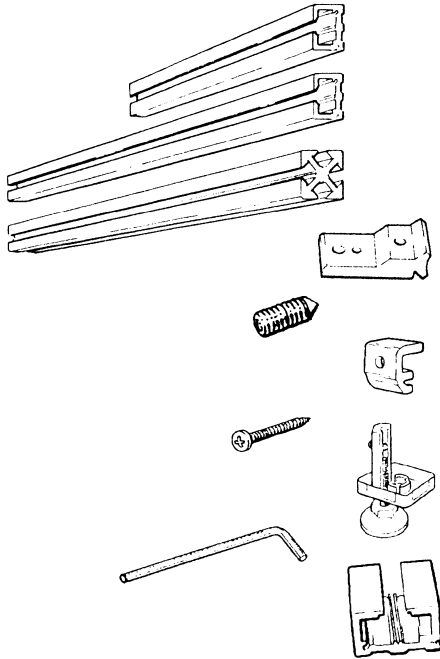

Artículo:-	Cantidad por 1,0 metros de "Big Bench"			
	1.0,1.5	2.0,2.5,3.0	3.5,4.0,4.5	5.0
Travesaño corto	4	6	8	10
Travesaño largo	4	8	12	16
Pata	4	6	8	10
Abrazadera de unión	16	28	40	52
Tornillo de sujeción	48	84	120	156
Fijador para banco de trabajo	4	6	8	10
Tornillo largo	4	6	8	10
Ajustador de altura	4	6	8	10
Llave hexagonal de 4 mm	1	1	1	1
Espaciador	1	1	1	1

Empaquetado en el tubo:

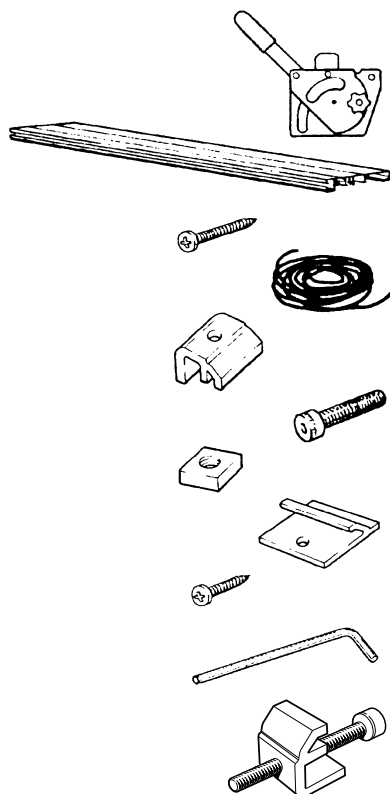

Artículo:-	Cantidad por 1,0 metros de "Big Bench"			
	1.0,1.5	2.0,2.5,3.0	3.5,4.0,4.5	5.0
Elevar y sujetar	(1,1)	(1,1)	(1,1)	(1,1)
Base de extrusión	1	1	1	1
Tornillo grande	6	6	6	6
Cable de silicio	1	1	1	1
Abrazadera de base	2	3	4	5
Tornillo hueco	2	3	4	5
Tuerca cuadrada	2	3	4	5
Fijador para banco de trabajo	2	4	6	8
Tornillo pequeño	2	4	6	8
Llave hexagonal de 5 mm	1	1	1	1
	2	4	6	8

El orden de montaje es muy importante; los diagramas que se proporcionan ofrecen una referencia rápida y permiten al lector familiarizarse con el montaje general del "Big Bench", el montaje detallado se describe en 4 etapas.

1ª etapa

Fijación las abrazaderas a las patas

El "Big Bench" de 1,0 m y de 1,5 m sólo tiene 4 patas; se ruega ignorar las dos patas centrales.

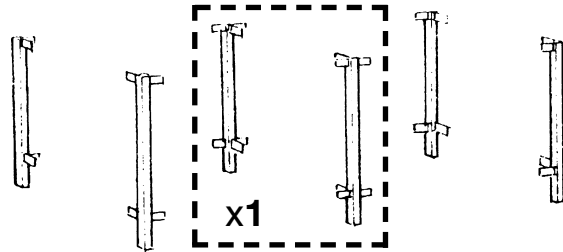
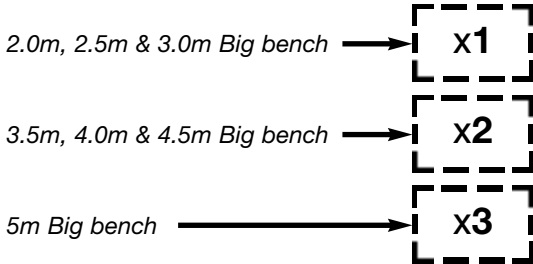

2ª etapa

Construcción de los bastidores de extremo.

Ignorar el bastidor central si est. montando un "Big Bench" de 1,0 m o de 1,5 m.

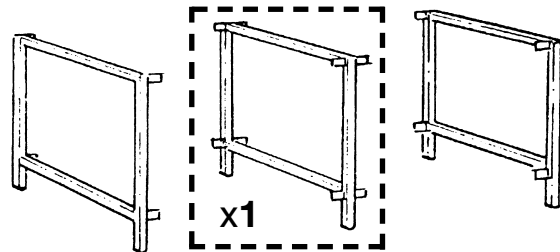
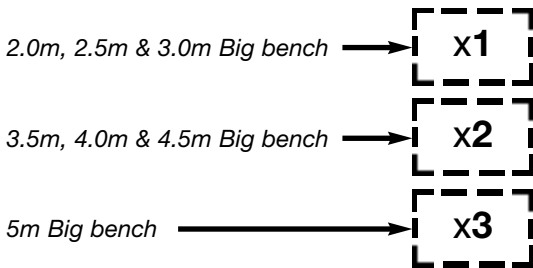

3ª etapa

Unir los bastidores de extremo y los travesaños cruzados para producir el banco.

1.0 & 1.5 Big bench

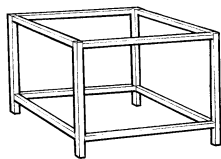

2.0, 2.5 & 3.0m Big bench

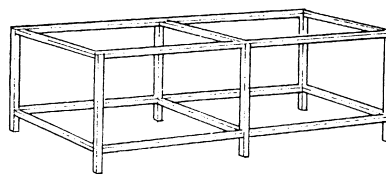

3.5, 4.0 & 4.5m Big bench

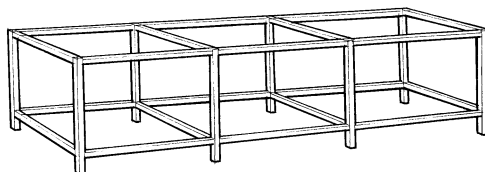

5m Big bench

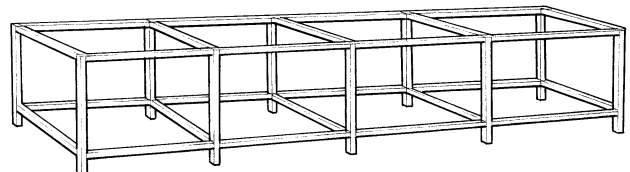

4ª etapa

Acoplar el mecanismo "Javelin" de elevación y soporte y la base de extrusión.

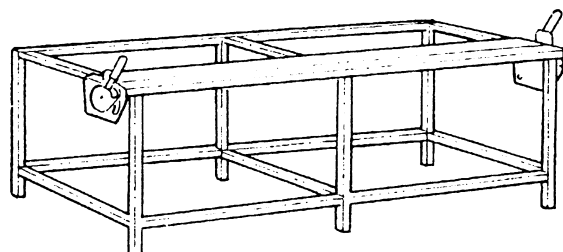

NOTA:

Las siguientes instrucciones asumen que el "Big Bench" tiene seis patas (2,0, 2,5, ó 3,0). Si usted está montando un "Big Bench" (1,0 ó 1,5) omitir el bastidor central.

1ª etapa

- Colocar un tornillo de fijación hacia atrás en cada una de las abrazaderas de fijación, no colocar los tornillos en los otros orificios.

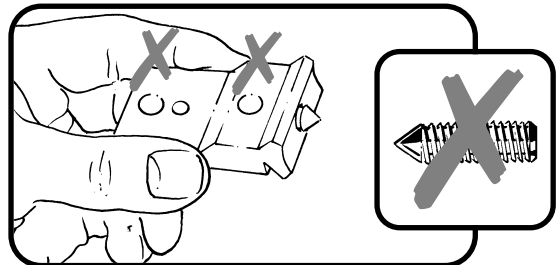
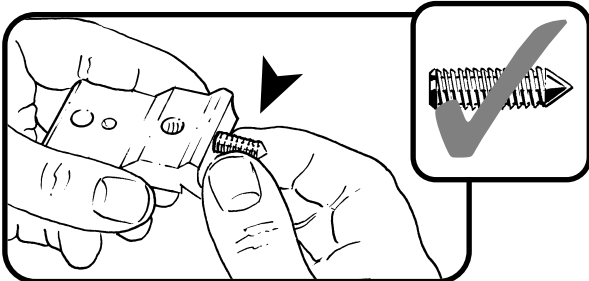

- Utilizando el espaciador, ajustar las abrazaderas a la parte superior de cada pata como se muestra; compruebe que:
 - Las abrazaderas están correctamente sujetas
 - El espaciador se encuentra ligeramente por encima del nivel superior de la pata, de forma que cuando se haya montado el nivel superior de la pata no quede por encima del travesaño.
 - Los tornillos de sujeción están totalmente ajustados.

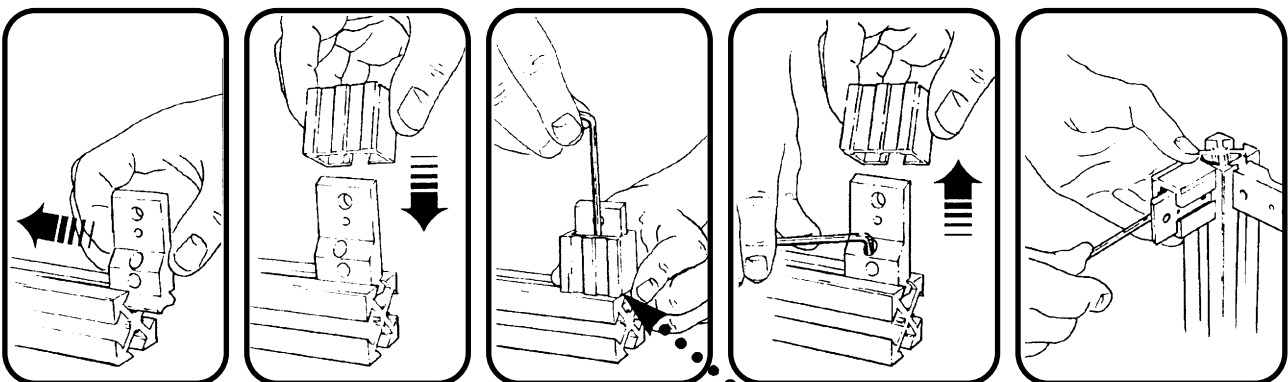
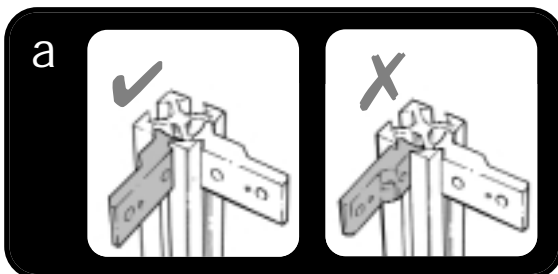
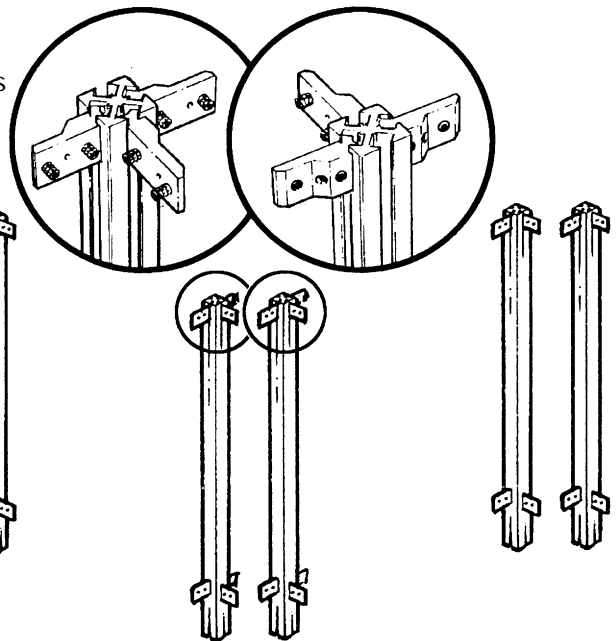

- Acolar las abrazaderas a la parte inferior de las patas (y en el mismo sentido como se muestra anteriormente), utilizando una cinta de medir o espaciador para colocarlo a fin de que se acomode a sus requerimientos.



4. Colocar los tornillos de fijación en cada uno de los dos orificios grandes de la abrazadera, atornillar sólo 2 ó 3 vueltas.

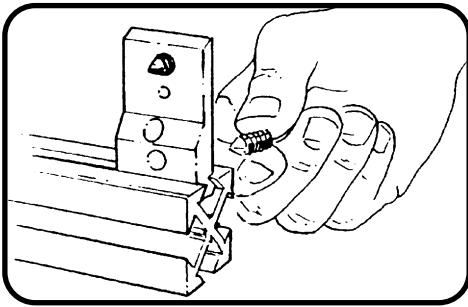

5. Fijar los ajustadores de altura en la parte inferior de cada pata. Colocar el ajustador en uno de los agujeros de la pata (es decir, en el mismo agujero en el que están las abrazaderas).

Colocar la parte inferior de la abrazadera de aluminio a nivel con la parte inferior de la pata y apretar el tornillo de fijación.

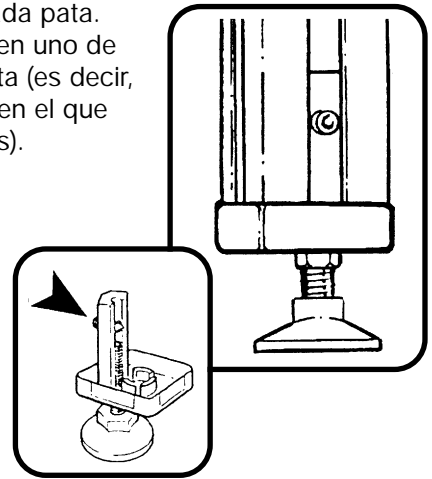

2ª etapa

1. Ajustar los dos travesaños cortos entre cada par de patas, comprobando que el orificio pequeño del travesaño esté más arriba.
2. Tirando de las dos patas a la vez (para cerrar cualquier espacio entre el extremo del travesaño y las patas) apretar todos los tornillos de fijación.

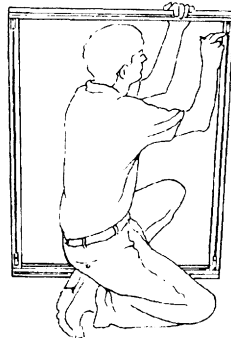

PARTE SUPERIOR

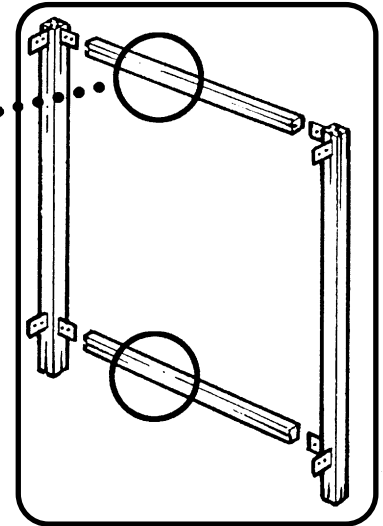
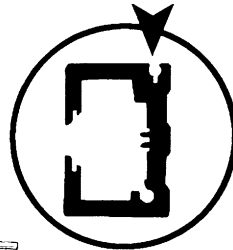

PARTE SUPERIOR

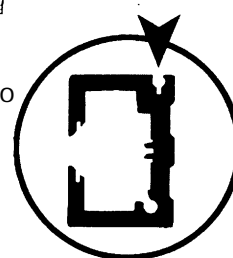

3ª etapa

1. Colocar uno de los bastidores de extremo en el suelo con las abrazaderas orientadas hacia arriba y colocar el travesaño largo sobre cada abrazadera (de nuevo comprobar que el orificio pequeño del travesaño esté hacia arriba).

2. Colocar:
el otro bastidor de extremo (si está montando un "Big Bench" de 1,0 m o de 1,5 m)

o

el bastidor central (si está montando un "Big Bench" de 2,0 m, 2,5 m ó 3,0 m)

sobre los travesaños y apretar los tornillos de fijación comprobando que no queden espacios entre los extremos del travesaño y las patas.

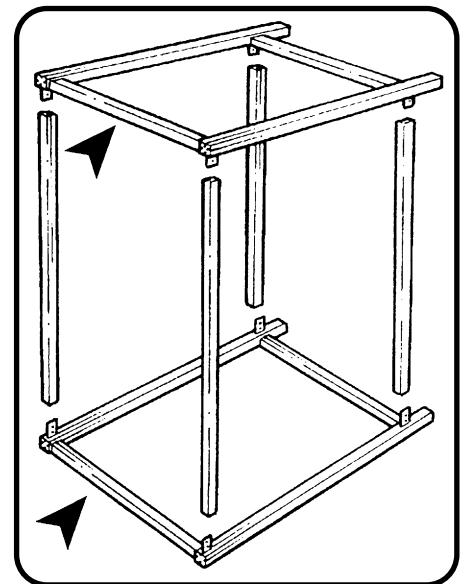
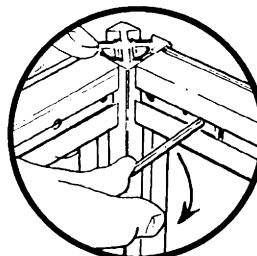

3. **Sólo para el "Big Bench" de 2,0 m, 2,5 m ó 3,0 m**

Colocar el bastidor sobre sus patas y los travesaños largos restantes entre el bastidor y el bastidor de extremo restante, apretar todos los tornillos de fijación, comprobando que no haya espacios entre los extremos del travesaño y las patas.

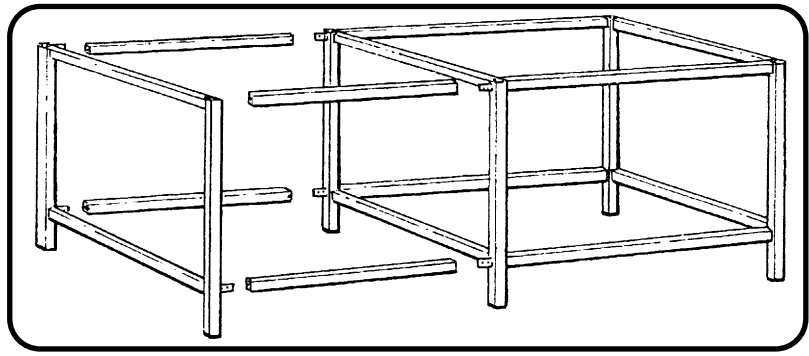

4ª etapa

1. Colocar la base de extrusión en el borde del banco, de forma que el borde cuelgue sobre el canto delantero de las patas. Deslizar las tuercas cuadradas en los espacios como se muestra y colocar una cerca de cada pata. Deslizar el banco de trabajo fijando las placas en sus orificios y colocarlas a aproximadamente el mismo espacio junto a la base de extrusión.

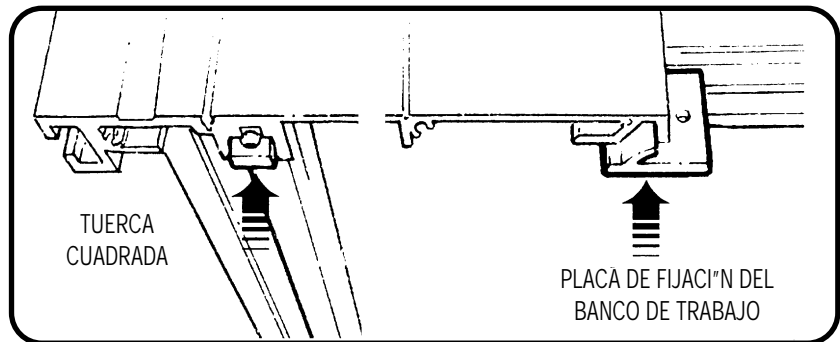
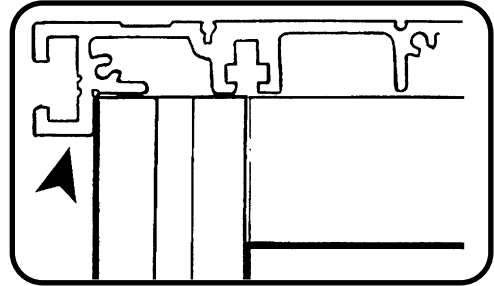

2. Utilizando la llave hexagonal de 5 mm fijar la base de extrusión en su posición sobre el banco, con las abrazaderas de la base y los tornillos.

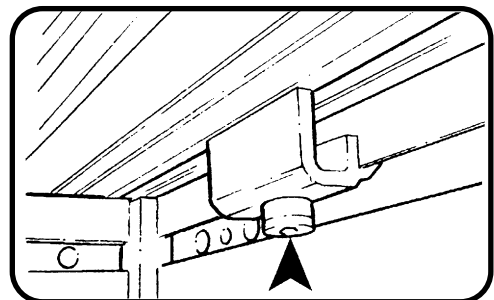

Vista desde abajo

3. Fijar el mecanismo de elevación y soporte a cada extremo de la base de extrusión con tres tornillos largos autoroscados en cada extremo, no apretar los tornillos demasiado en esta etapa.

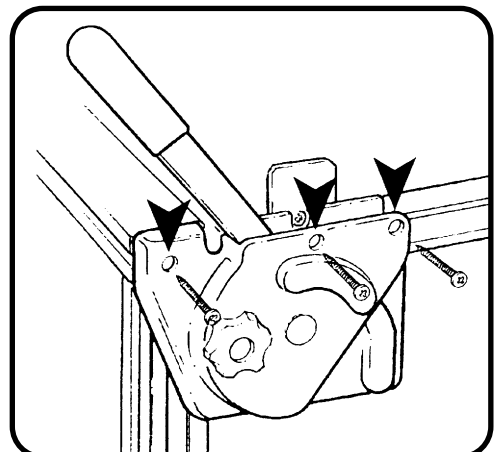

4ª etapa

4. Fijar el banco de trabajo en su posición utilizando
 - a) La fijación grande del banco de trabajo y los tornillos grandes como se muestra.
 - b) los tornillos pequeños para fijar las placas de fijación del banco de trabajo.

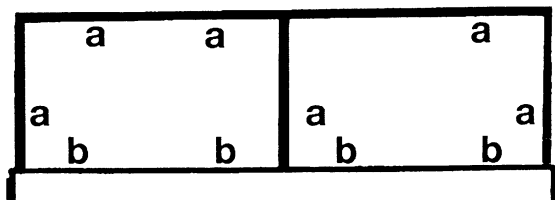
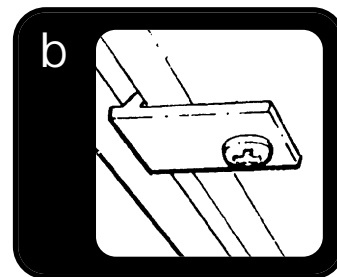
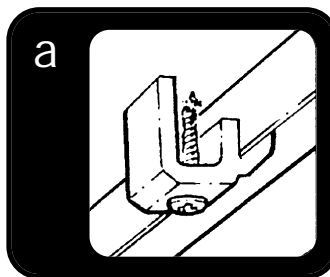

Vista de plano

Colocar las abrazaderas aproximadamente como se muestra a la izquierda.

5. Colocar la cuchilla Javelin sobre los dos mecanismos de elevación y soporte, deslizando la lengua en la ranura interior de los casquillos de extremo de Javelin.

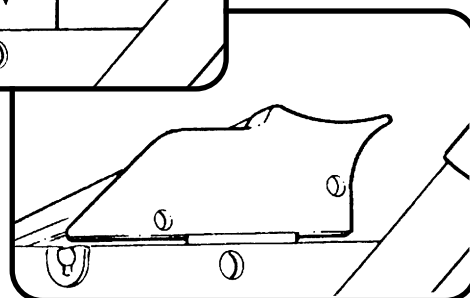
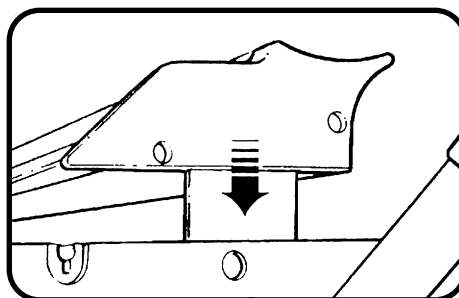
**NOTA:**

El botón de fricción de cada mecanismo puede ajustarse para sujetar el Javelin a cualquier peso que haga la alineación precisa más fácil cuando se utilice.

6. Mover el cabezal de cortado a un extremo de Javelin y oprimir la cuchilla, ajustar la posición de los mecanismos de elevación y soporte, la cuchilla funcionará centralmente en la ranura de la base de extrusión, apretar los tres tornillos para apretar la elevación y el soporte.

Repetir para los otros extremos.

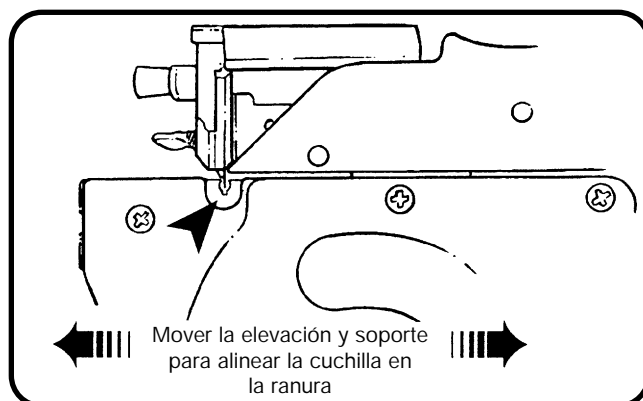

7. Colocar el banco en su posición y utilizando un nivel de precisión ajustar las patas para asegurar que la superficie superior de la mesa está plana. Si la mesa no estuviera plana, en particular a lo largo de su longitud, podría dificultar el soporte de la pieza de trabajo en posición y la longitud total del corte.

8. Si se está cortando una película fina de papel, compruebe que el material pueda agarrarse a lo largo de toda la longitud del banco. Pase un trozo pequeño del material, de aproximadamente 25 cm de ancho debajo de la cortadora y asegúrese que se mantenga en posición, relícese esto a lo largo de toda la longitud.

Si la cortadora no agarra adyacente a una de las patas del banco, ajuste el pie para subir ligeramente esa sección del banco y vuelva a hacer la prueba.

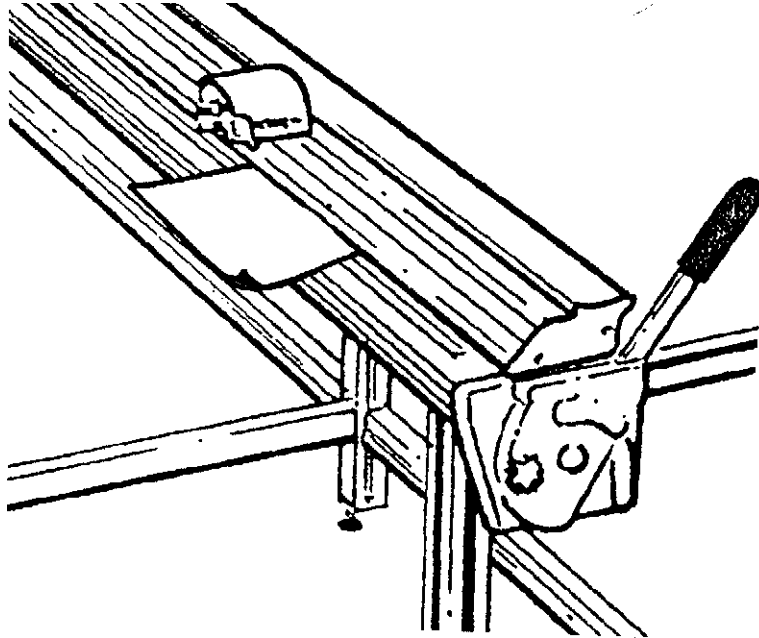

Si la barra de corte entre las patas no agarra el papel, coloque un soporte de nivelación y atorníllelo en la viga situada en la sección inferior de la extrusión de la base. Colóquelo en el centro del área que no está apretando y apriete el tornillo hasta que el papel quede sujeto eficientemente.

Compruebe que toda la barra de corte esté sujetando, añada más soportes de nivelación y ajústelos si fuera necesario.

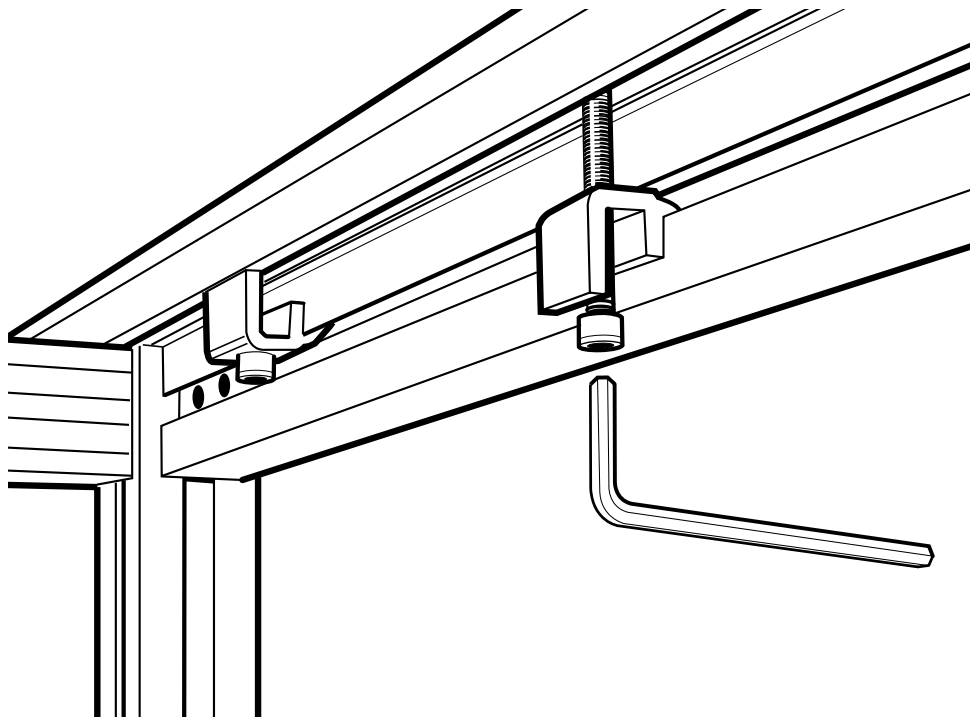

Big Bench

ⓕ INSTRUCCIONES DE MONTAJE

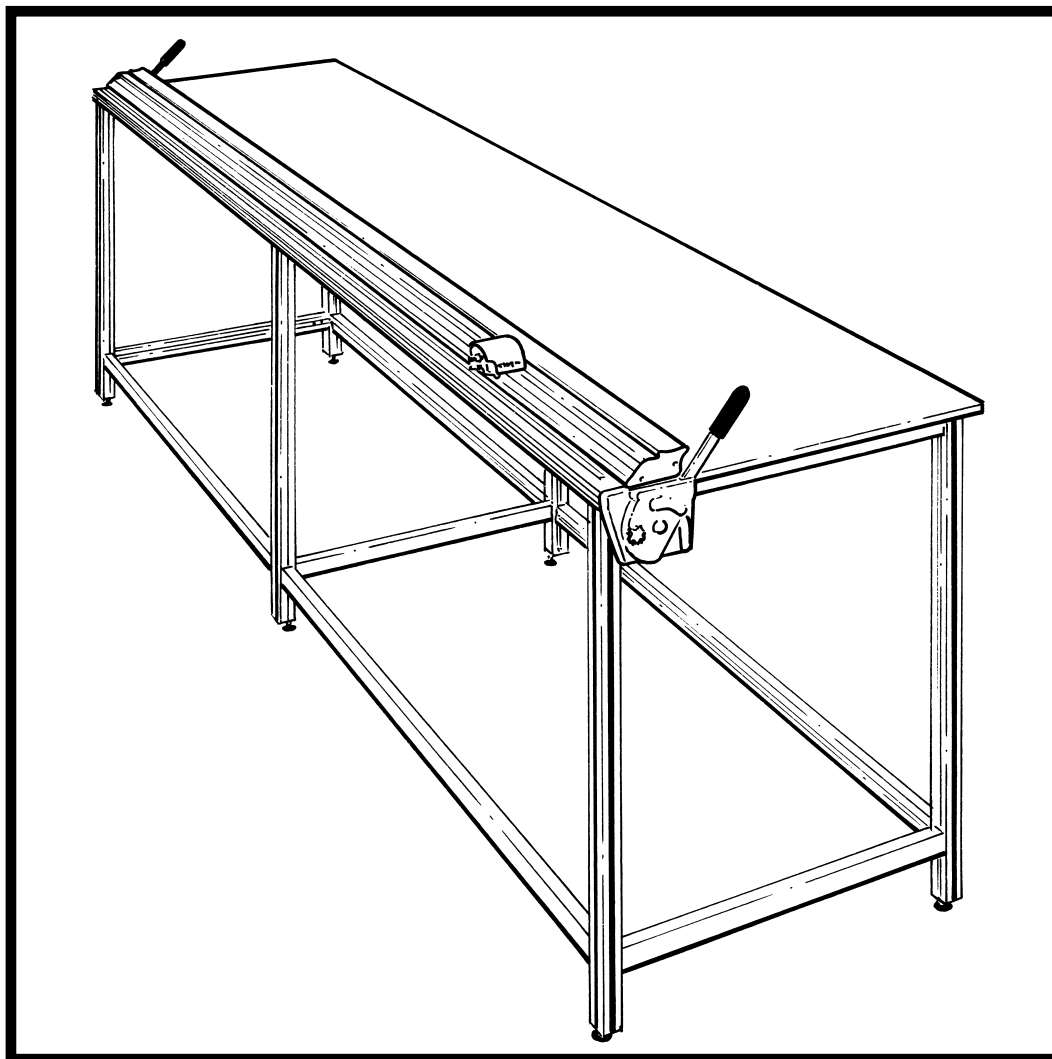

Nous vous remercions d'avoir choisi l'établi "Big Bench" de Keencut. Nous avons fait tous les efforts possibles pour vous proposer un produit remarquablement construit promettant de nombreuses années de bon fonctionnement.

Keencut - the world's finest cutting machines



Vous devez avoir;

Packed in the Rectangular Boxes:

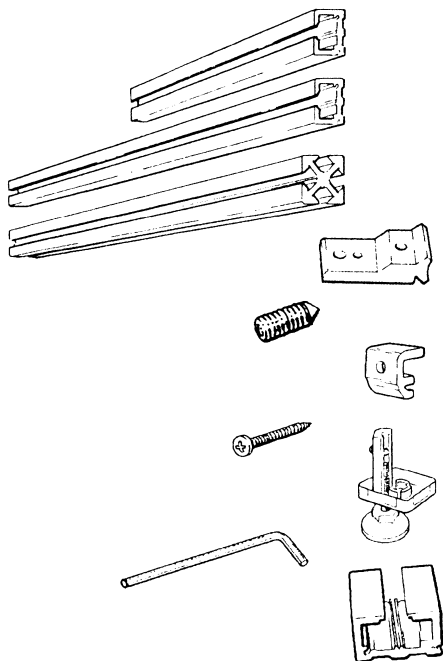

Pièces	Quantité pour 1 établi "Big Bench"			
	1.0,1.5	2.0,2.5,3.0	3.5,4.0,4.5	5.0
Courte poutre	4	6	8	10
Longue poutre	4	8	12	16
Jambe	4	6	8	10
Support d' Assemblage	16	28	40	52
Vis sans tête	48	84	120	156
Fixation de Plan de Travail	4	6	8	10
Longue vis	4	6	8	10
Vis de Réglage de Hauteur	4	6	8	10
Clé Hexagonale 4 mm	1	1	1	1
Entretoise	1	1	1	1

Packed in the TUBE:

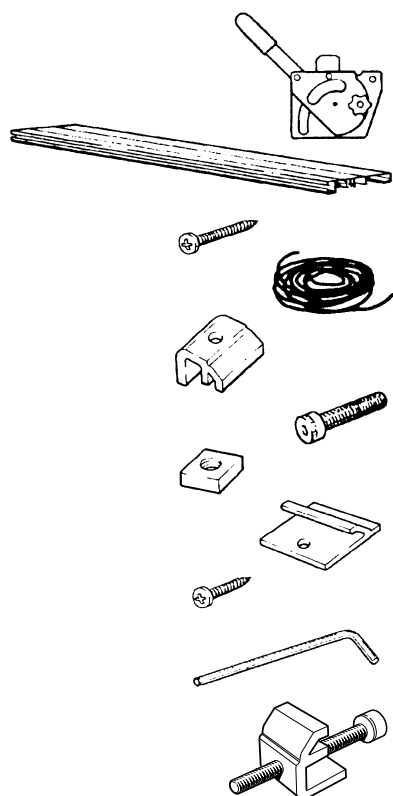

Pièces	Quantité pour 1 établi "Big Bench"			
	1.0,1.5	2.0,2.5,3.0	3.5,4.0,4.5	5.0
Dispositif de Maintien et de Levage	(1,1)	(1,1)	(1,1)	(1,1)
Plaque de Base Extrudée	1	1	1	1
Grande vis	6	6	6	6
Cordon Silicone	1	1	1	1
Fixation de la Plaque de Base	2	3	4	5
Boulon à Tête	2	3	4	5
Ecrou Carré	2	3	4	5
Fixation de Plan de Travail	2	4	6	8
Petite Vis	2	4	6	8
Clé Hexagonale 5 mm	1	1	1	1
	2	4	6	8

L' Ordre de Montage est très important - Les schémas suivants sont donnés uniquement pour consultation rapide et permettront au lecteur de se familiariser avec le montage général de l'établi "Big Bench", dont le montage détaillé comporte quatre phases.

Phase 1

Fixation des Supports sur les Jambes.

Les établis "Big bench" 1,0 m & 1,5 m n'ont que 4 jambes. Ignorez la paire centrale de jambes

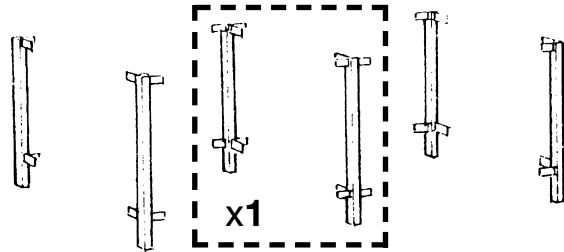
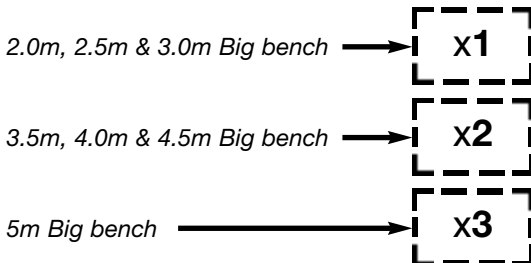

Phase 2

Montez les cadres d'extrémité.

Ne vous occupez pas du cadre central si vous montez un établi Big bench 1,0 m ou 1,5 m.

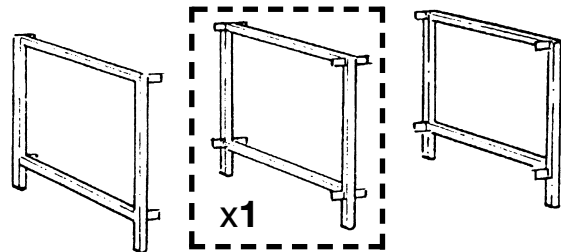
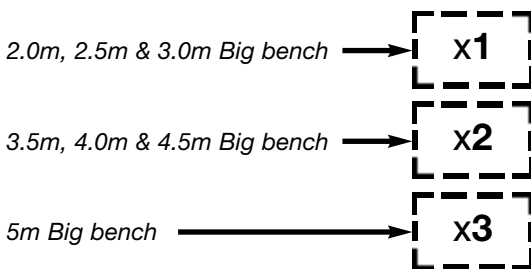

Phase 3

Assemblez les cadres d'extrémité et les traverses pour obtenir l'établi.

1.0 & 1.5 Big bench

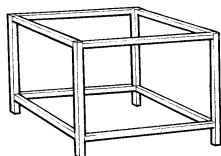

2.0, 2.5 & 3.0m Big bench

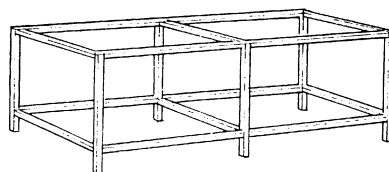

3.5, 4.0 & 4.5m Big bench

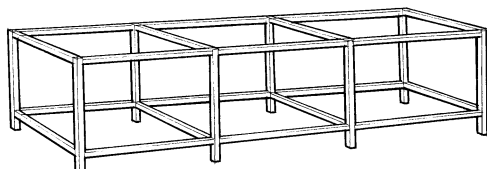

5m Big bench

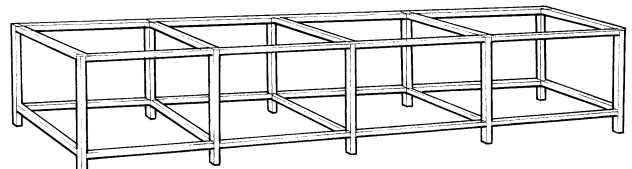

Phase 4

Fixez les mécanismes de levage et de maintien "Javelin" lift & la plaque de base extrudée.

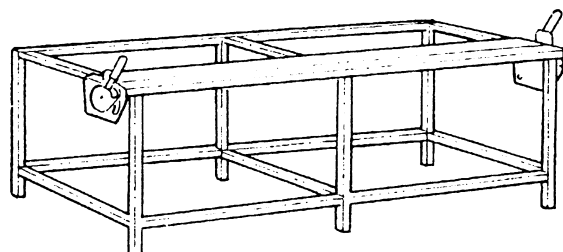

NOTA:

Les instructions suivantes supposent que l'établi "Big Bench" a six jambes (2,0, 2,5, ou 3,0). Si vous montez un établi "Big Bench (1,0 ou 1,5) , n'installez pas le cadre intermédiaire.

Phase 1

1. Placez une vis sans tête en arrière dans chacun des supports d'assemblage. -ne placez pas de vis dans les autres trous.

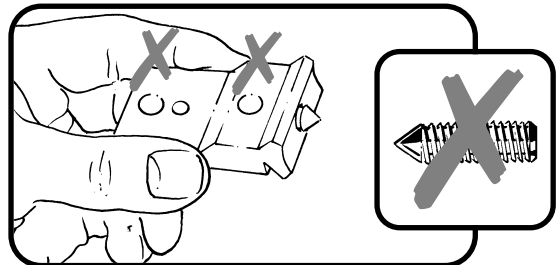
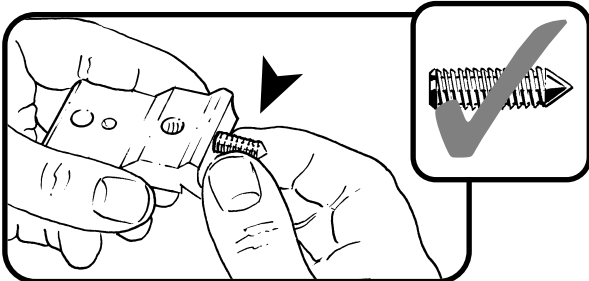
**Stage 1**

2. En utilisant l'entretoise, installez les supports sur le sommet de chaque jambe comme indiqué. Vérifiez:
 - a). Que les supports sont installés correctement sur la périphérie.
 - b). Que l'entretoise est légèrement au-dessus du niveau supérieur de la jambe ; ainsi, une fois montée, le niveau supérieur de la jambe n'est pas au-dessus de la poutre.
 - c). Que les vis sans tête sont serrées à fond.

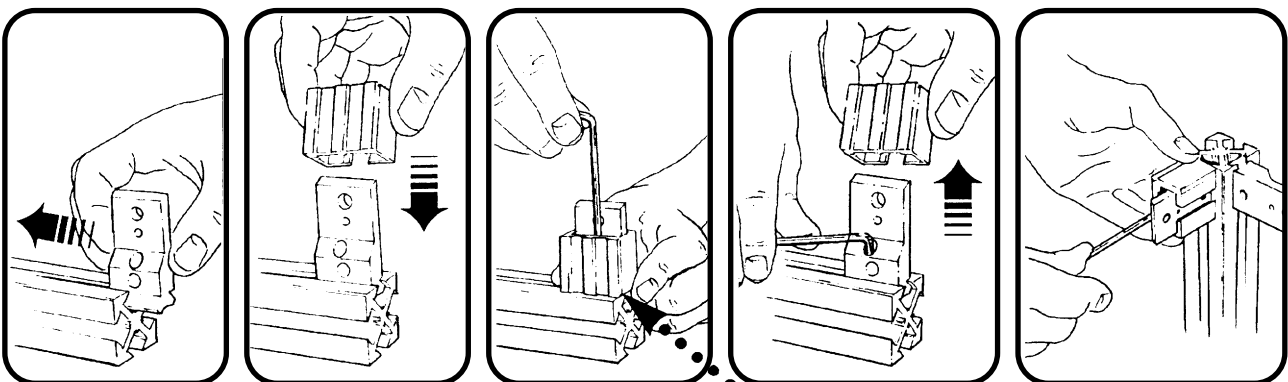
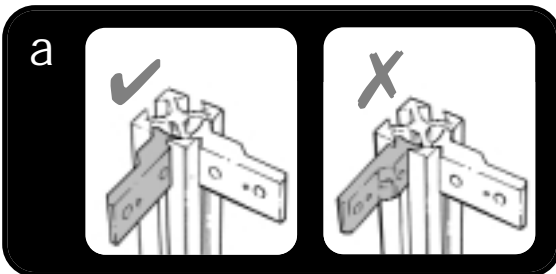
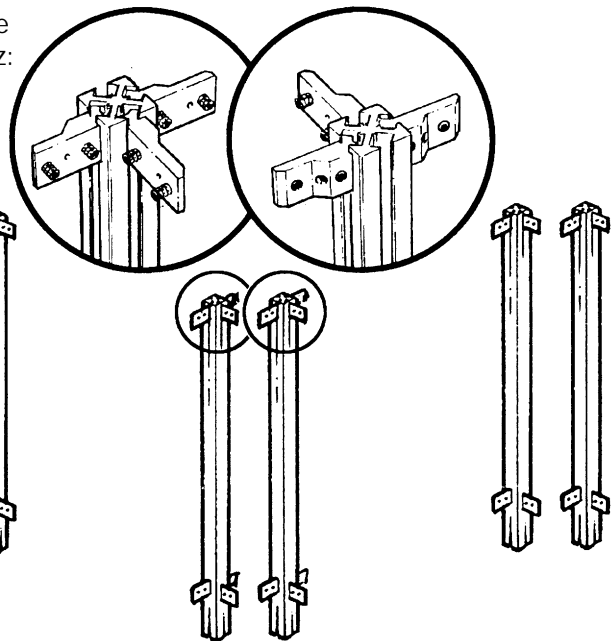

3. Fixez les supports sur la base des jambes (sur la périphérie comme indiqué ci-dessus), en utilisant un ruban de mesure ou une entretoise pour les positionner suivant vos exigences.



4. Placez des vis sans tête dans un des 2 grands trous du support. Vissez-les seulement de 2 ou 3 tours.

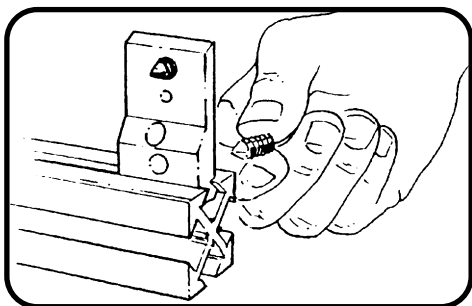

5. Fixez les vis de réglage de hauteur à la base de chaque jambe. Positionnez la vis de réglage dans l'une des rainures internes de la jambe (c'est à dire dans la même rainure où les supports sont installés.)

Alignez le niveau inférieur du support en aluminium avec la base de la jambe et serrez à fond la vis sans tête.

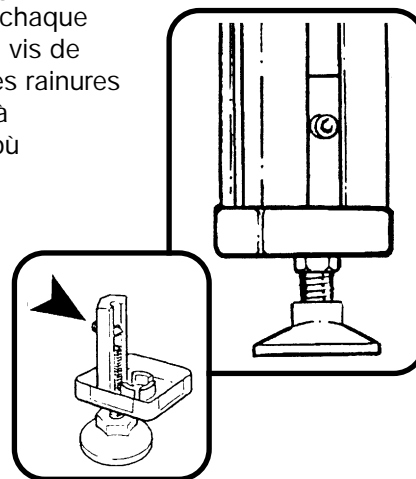

Phase 2

1. Installez les deux courtes poutres entre chaque paire de jambe en vérifiant que la petite rainure dans la poutre est en position supérieure.
2. En tirant ensemble sur les deux jambes (pour fermer les jeux entre l'extrémité de la poutre et les jambes), serrez toutes les vis sans tête.

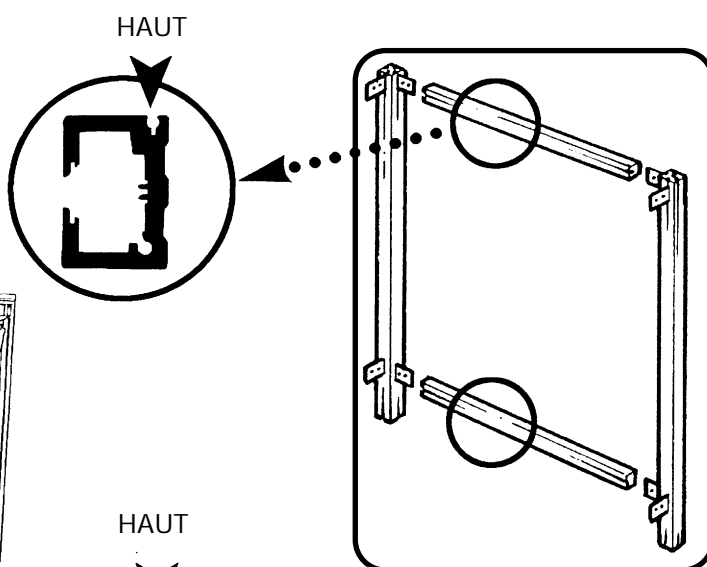
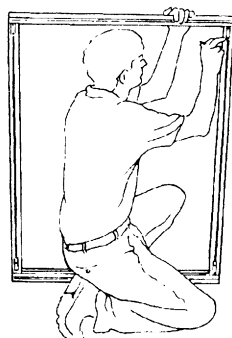

Phase 3

1. Placez un cadre d'extrémité sur le sol en dirigeant les supports vers le haut et placez une longue poutre sur chaque support (en vérifiant à nouveau que la petite rainure dans la poutre est en position supérieure)

2. Placez soit:
l'autre cadre d'extrémité (si vous montez un établi Big bench 1,0 m ou 1,5 m)

ou

Le cadre central (si vous montez un établi Big bench 2,0 m, 2,5 m ou 3,0 m)

sur les poutres et serrez les vis sans tête en vérifiant qu'il n'y a pas de jeu entre les extrémités de poutre et les jambes.

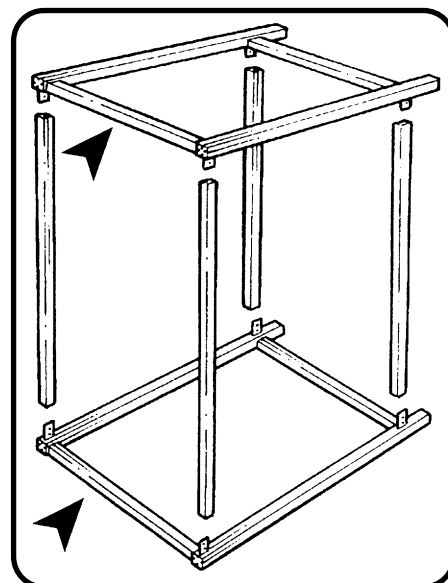
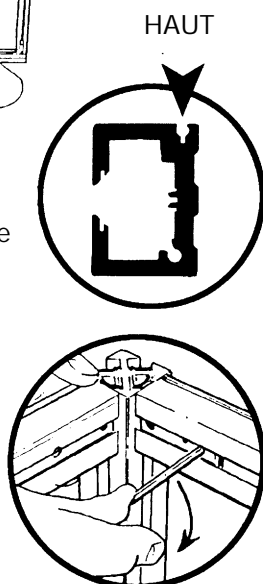

3. **établis Big bench 2,0 m, 2,5 m ou 3,0 m seulement**

Posez la cadre sur ces pieds et placez les autres longues poutres entre le cadre et l'autre cadre d'extrémité, serrez de nouveau toutes les vis sans tête en vérifiant qu'il n'y a pas de jeu entre les extrémités de poutre et les jambes

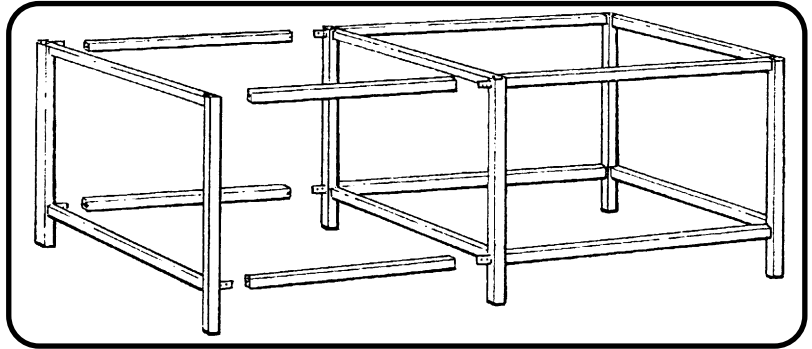

Phase 4

1. Placez la plaque de base extrudée sur le bord de l'établi de manière à ce que la lèvre soit suspendue sur le bord avant des jambes. Faites coulisser les écrous carrés dans la cavité comme indiqué et placez-en un à côté de chaque jambe. Faites coulisser les plaques de fixation du plan de travail dans leur rainure et positionnez-les le long de la plaque de base extrudée en les espaçant de manière identique.

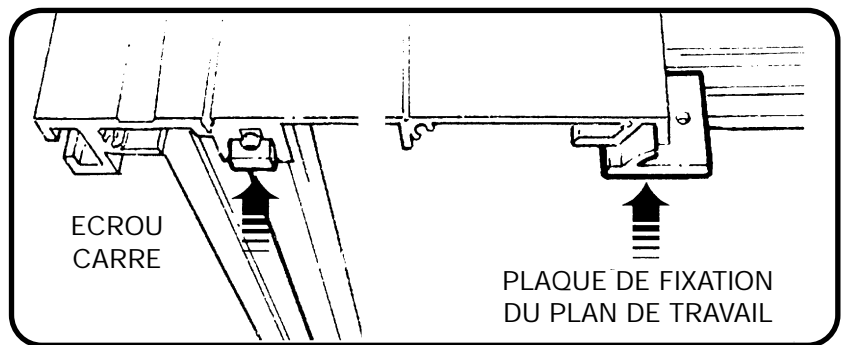
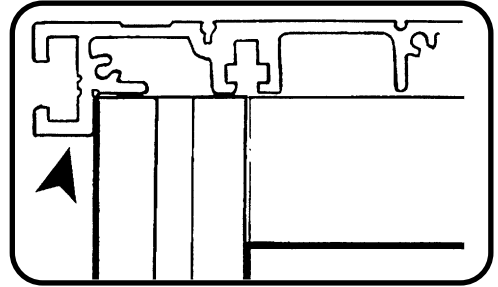

2. A l'aide de la clé hexagonale 5 mm, fixez en place la plaque de base extrudée sur l'établi à l'aide des dispositifs de serrage de la plaque et de boulons à tête.

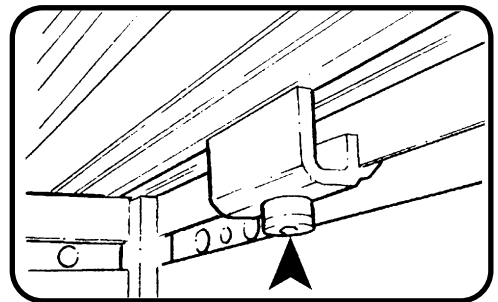

Vue par en dessous

3. Fixez les mécanismes de maintien et de levage sur chaque extrémité de la plaque de base extrudée en utilisant les trois grandes vis auto taraudées à chaque extrémité ; pour le moment, ne serrez pas à fond les vis.

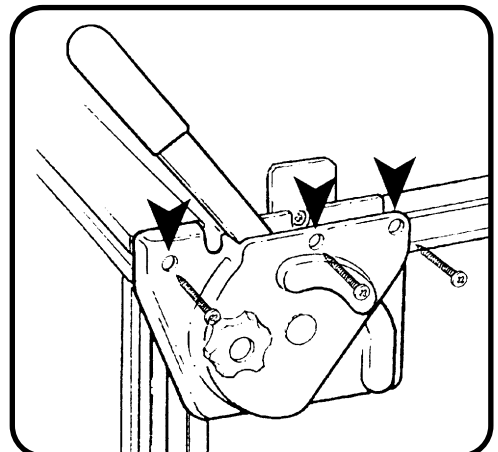

Stage 4 – cont'd

4. Fixez le Plan de Travail en place en utilisant
- La grande fixation et les grandes vis comme indiqué.
 - Les petites vis pour fixer les plaques de maintien du Plan de Travail.

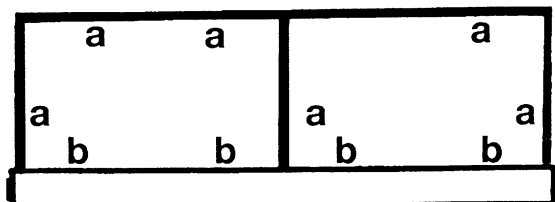
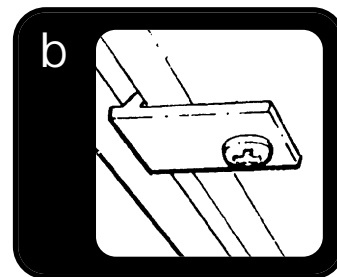
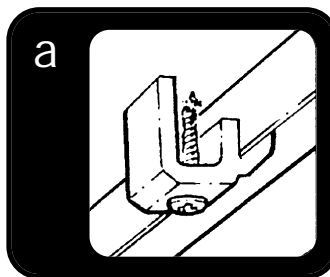

Vue en Plan

Positionnez les supports à peu près à la position indiquée à gauche.

5. Positionnez l'outil de coupe Javelin sur les deux mécanismes de levage et de maintien en faisant coulisser la languette dans la fente à l'intérieur des chapeaux d'extrémité de l'outil Javelin.

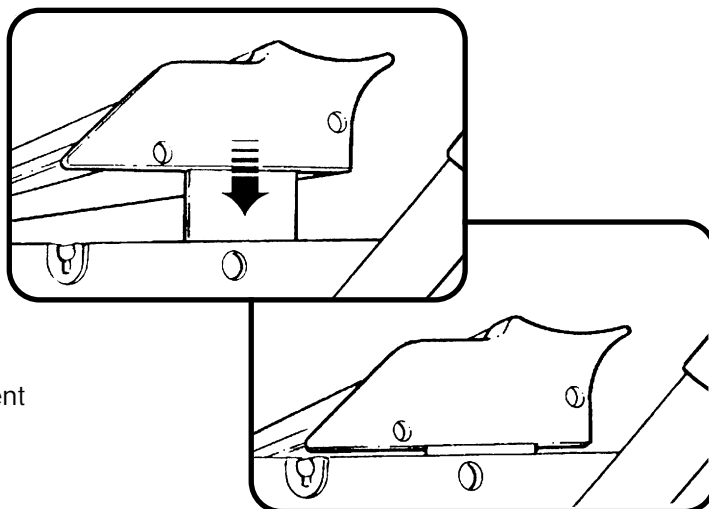
**NOTA:**

Le bouton à friction sur chaque mécanisme peut être réglé pour maintenir l'outil Javelin à une hauteur quelconque, ce qui permettra un alignement beaucoup plus précis en cours d'utilisation.

6. Déplacez la tête de coupe à une extrémité de l'outil Javelin et appuyez sur la lame; réglez la position du mécanisme de levage et de maintien pour que la lame se déplace au centre de la fente sur la plaque de base extrudée; serrez les trois vis pour maintenir le mécanisme de levage et de maintien. Répétez l'opération pour l'autre extrémité.

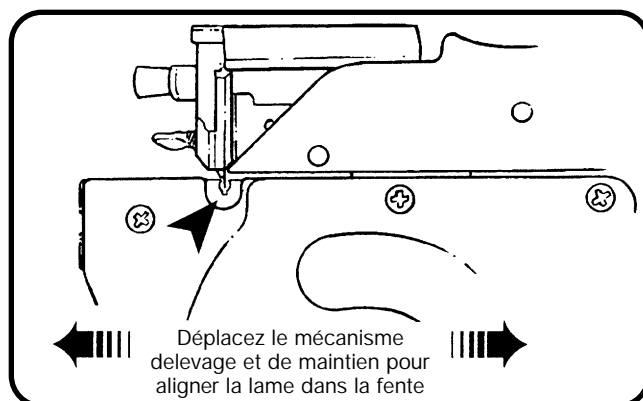

7. Positionnez en place l'établi et, à l'aide d'un niveau à bulle précis, réglez le pied pour que la surface supérieure de la table soit plate. Si la table n'est pas plate, en particulier le long de sa longueur, il sera difficile de maintenir la pièce en place sur toute la longueur de coupe.

8. Si vous coupez un film ou un papier mince, vérifiez qu'il est bien serré sur toute la longueur du banc. Passez un petit morceau de papier d'environ 25cm (10") de large sous la lame et vérifiez qu'il est bien maintenu ; recommencez l'opération sur toute la longueur.

Si le papier n'est pas bien serré par la lame à coté d'un support du banc, soulevez légèrement cette partie du banc et testez à nouveau.

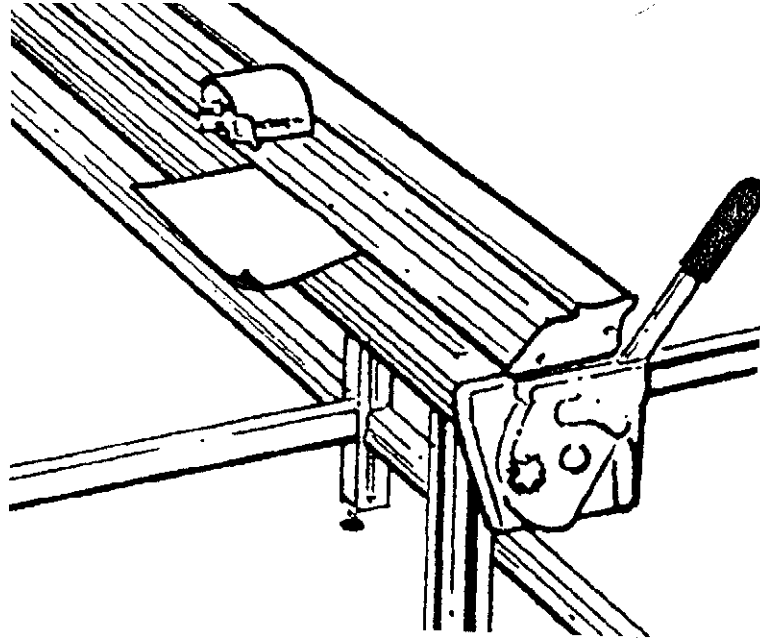

Si le papier n'est pas bien serré par la barre de découpe entre les montants, placez une cale de mise à niveau et vissez la membrure sur la face inférieure du profilé de base. Positionnez-la au milieu de la partie qui n'est pas serrée et serrez la vis jusqu'à ce que le papier soit efficacement serré. Vérifiez que la barre de découpe serre bien, ajoutez d'autres cales de mise à niveau et réglez si nécessaire.

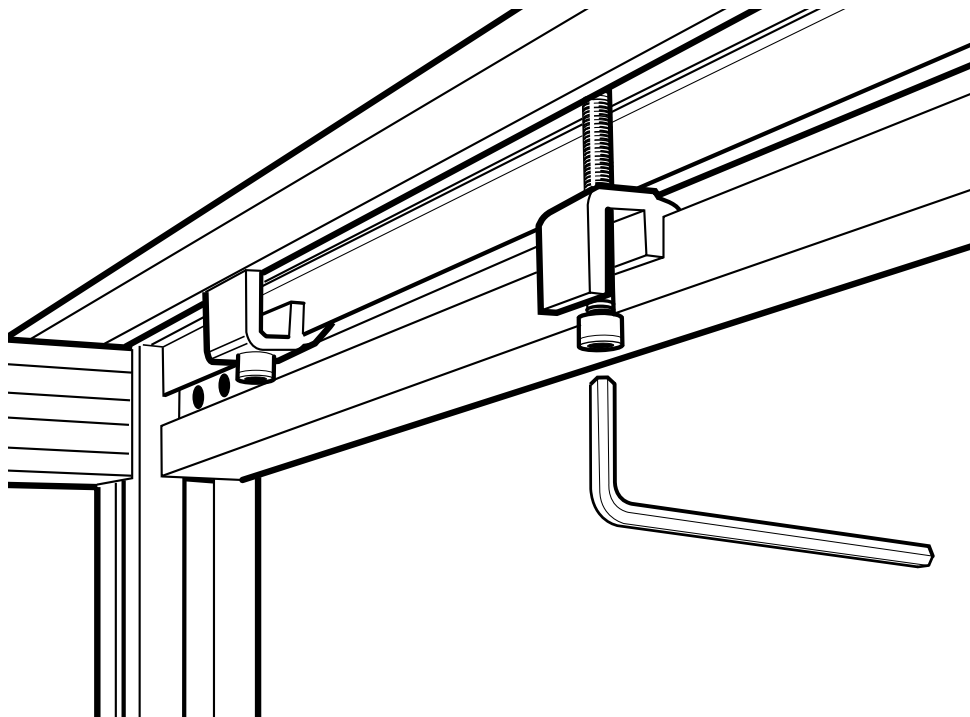

Big Bench

① ISTRUZIONI PER L'ASSEMBLAGGIO

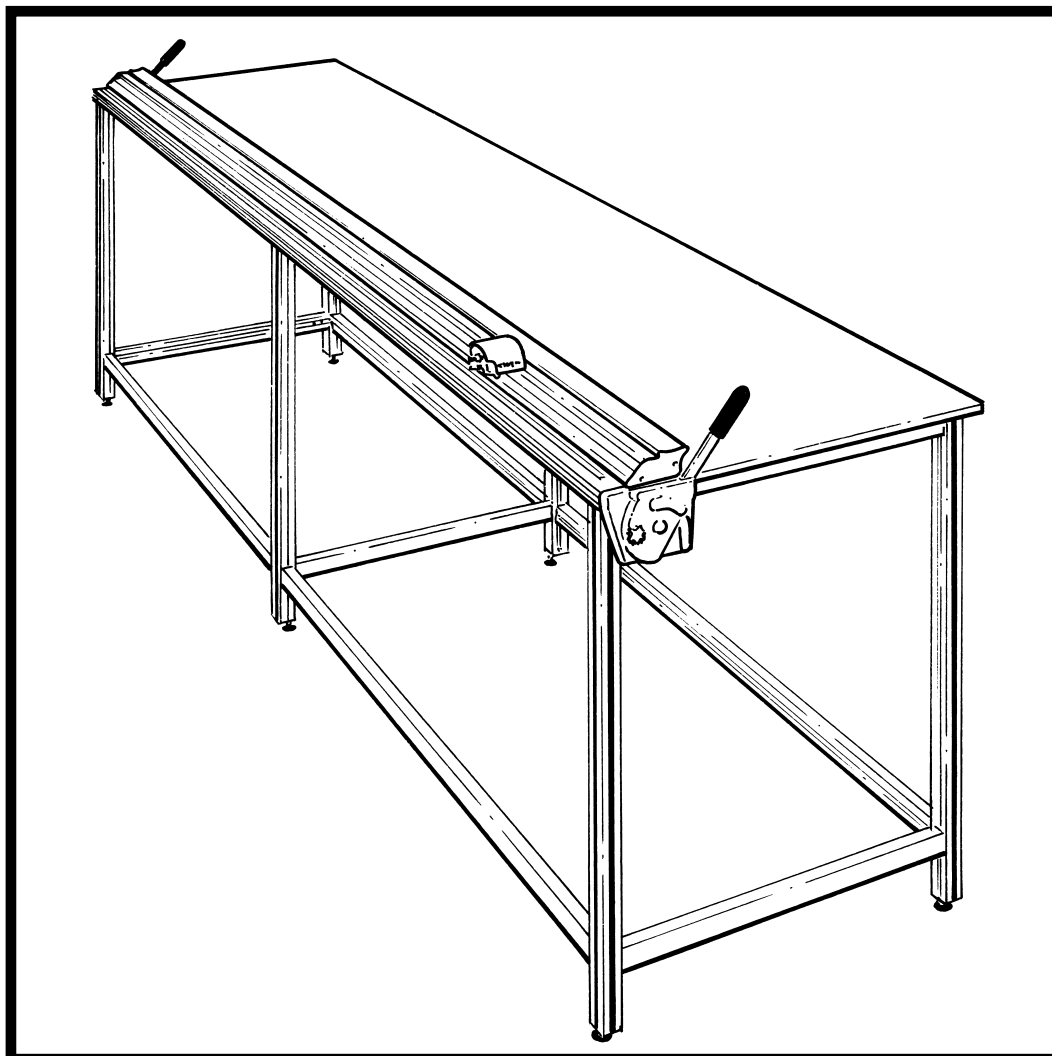

Grazie per aver scelto il "Big Benche". Sono stati impiegati tutti gli sforzi allo scopo di fornirvi un prodotto realizzato con eccellenza con la promessa di molti anni di buon servizio.

Keencut - the world's finest cutting machines



Dovreste avere:

Imbalto nelle scatole rettangolari:

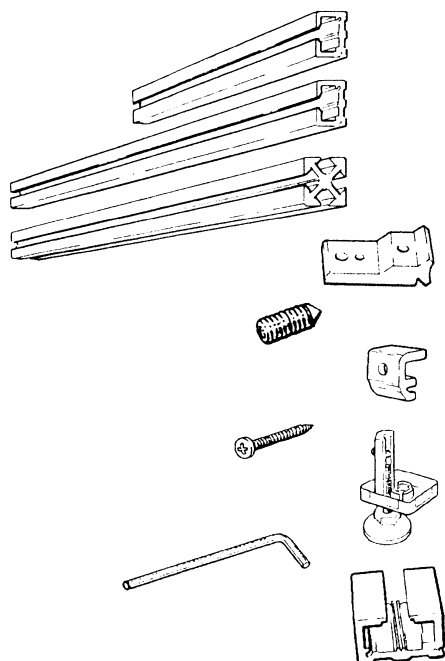

Articolo	Quantità per "Big Bench"			
	1.0,1.5	2.0,2.5,3.0	3.5,4.0,4.5	5.0
Braccio corto	4	6	8	10
Braccio lungo	4	8	12	16
Gamba	4	6	8	10
Staffa di giunzione	16	28	40	52
Vite senza testa	48	84	120	156
Dispositivi di fissaggio superficie di lavoro	4	6	8	10
Vite lunga	4	6	8	10
Regolatore altezza	4	6	8	10
Chiave esagonale di 4 mm	1	1	1	1
Distanziale	1	1	1	1

Imballato nel tubo:

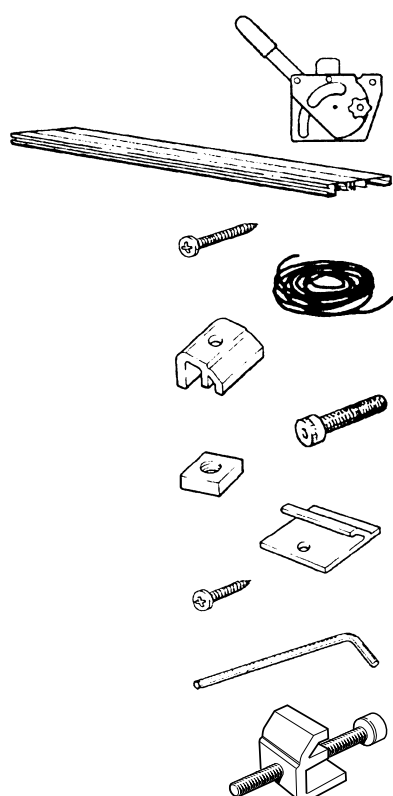

Articolo	Quantità per "Big Bench"			
	1.0,1.5	2.0,2.5,3.0	3.5,4.0,4.5	5.0
Solleva e mantieni	(1,1)	(1,1)	(1,1)	(1,1)
Estrusione di base	1	1	1	1
Vite grande	6	6	6	6
Corda al silicone	1	1	1	1
Morsa di base	2	3	4	5
Vite senza dado	2	3	4	5
Dado quadro	2	3	4	5
Dispositivi di fissaggio superficie di lavoro	2	4	6	8
Vite piccola	2	4	6	8
Chiave esagonale di 5mm	1	1	1	1
	2	4	6	8

L'ordine di assemblaggio è davvero importante - i seguenti disegni servono soltanto per riferimento rapido e servono a consentire al lettore di familiarizzarsi con l'assemblaggio generale del "Big Bench", l'assemblaggio generale viene descritto in 4 stadi.

Stadio 1

Fissare le staffe alle gambe

I "Big Bench" di 1m e di 1,5m hanno soltanto 4 gambe - ignorare la coppia centrale delle gambe.

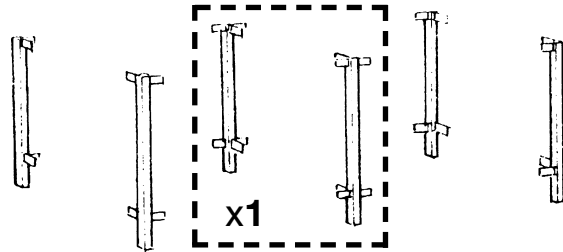
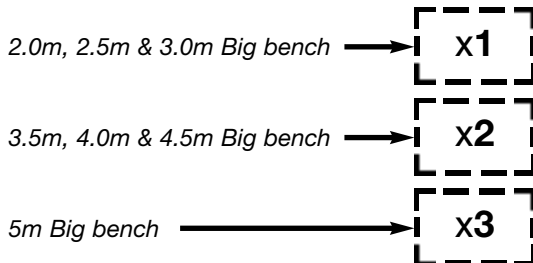

Stadio 2

Montare i telai posteriori.

Ignorare il telaio centrale se si sta montando un Big Bench da 1,0m o 1,5m.

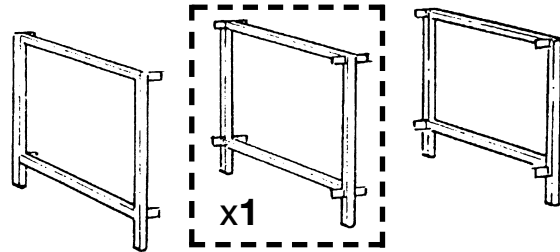
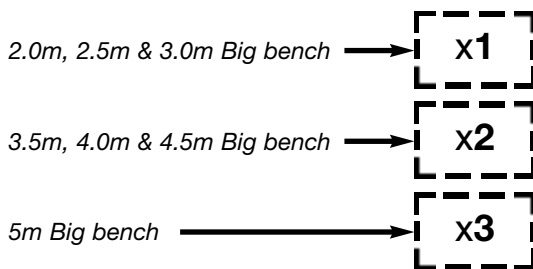

Stadio 3

Collegare il telai finali e gli bracci incrociati per produrre il banco.

1.0 & 1.5 Big bench

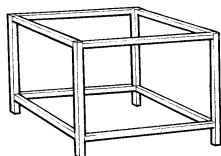

2.0, 2.5 & 3.0m Big bench

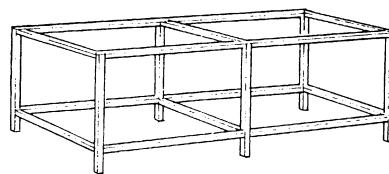

3.5, 4.0 & 4.5m Big bench

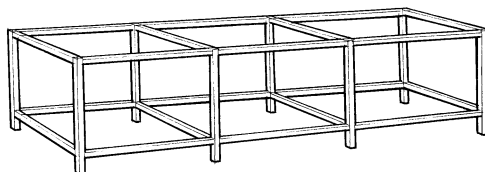

5m Big bench

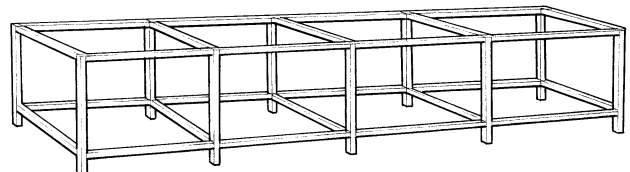

Stadio 4

Collegare il sollevamento "Javelin" e tenere il meccanismo e l'estrusione della base.

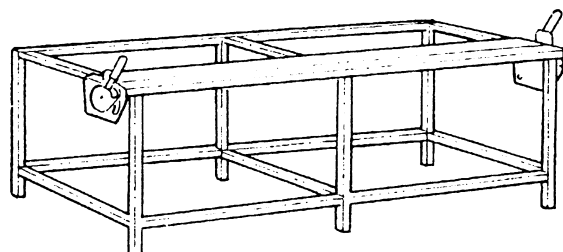

NOTA:

Le seguenti istruzioni presumo che il "Big Bench" abbia sei gambe. Se si sta montando un "Big Bench" (1,0m o 1,5m) omettere il telaio centrale.

Stadio 1

1. Mettere all'inverso una vite senza testa in ciascuna delle staffe di giuntura - non mettere delle viti in altri fori.

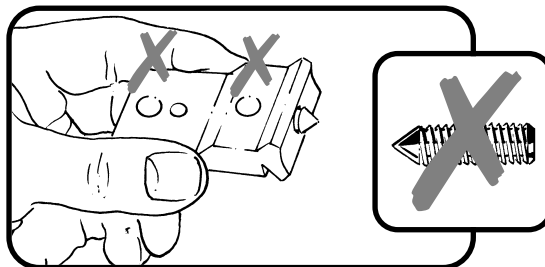
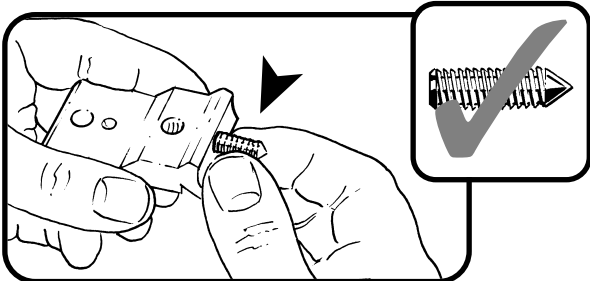
**Stadio 1**

2. Usando il distanziale, montare le staffe in cima ciascuna gamba come illustrato - assicurarsi che:

- Le staffe vengano montate nel senso corretto
- Il distanziale sia leggermente oltre il livello superiore della gamba, in modo che quando il livello superiore della gamba non sia oltre il braccio.
- Le viti senza testa siano completamente serrate.

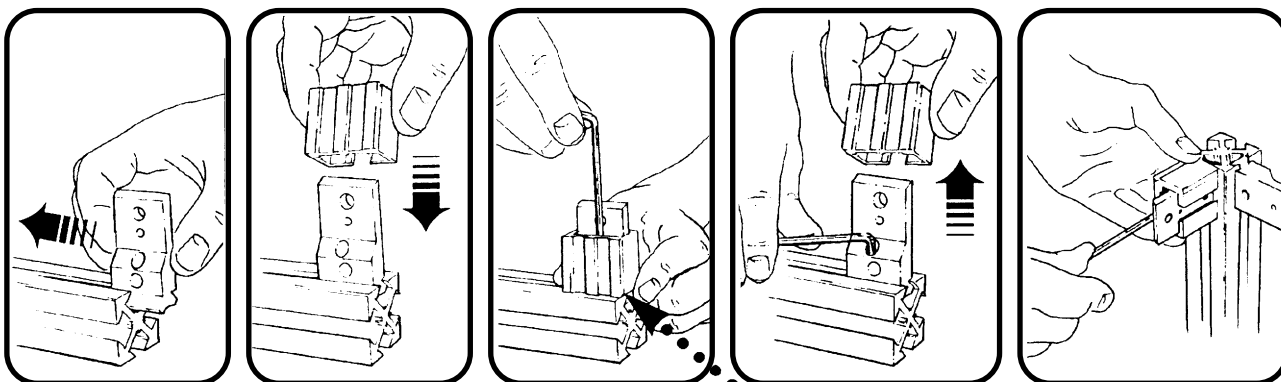
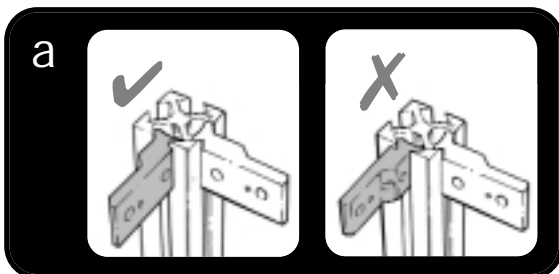
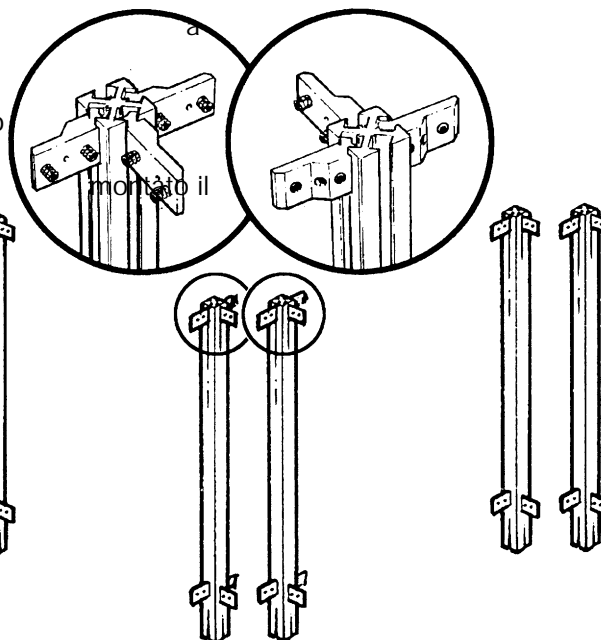

3. Collegare le staffe al fondo delle gambe (e in senso corretto come illustrato sopra), usando un nastro per misurare o un distanziale per posizzarle secondo le esigenze.



4. Mettere le viti senza testa in ciascuno dei fori grandi della staffa, avvitarle soltanto di 2 o 3 giri.

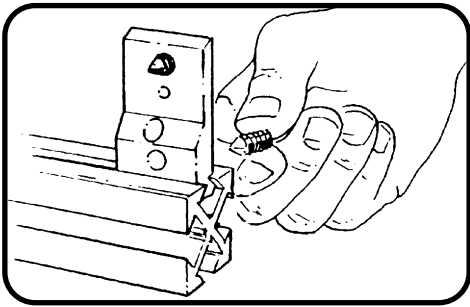

5. Fissare i regolatori dell'altezza nel fondo di ciascuna gamba. Posizionare il regolatore in una delle scanalature interne della gamba (ossia, la stessa scanalatura delle staffe montate).

Posizionare il fondo della staffa di alluminio a livello col fondo della gamba e serrare completamente la vite senza testa.

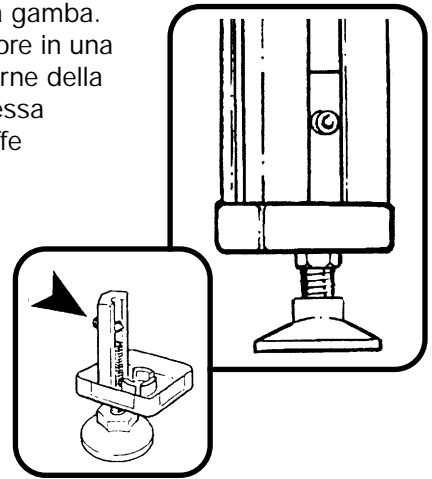

Stadio 2

1. Montare i due bracci corti tra ciascuna coppia di gruppo di gambe assicurandosi che la piccola scanalatura del braccio sia rivolta verso l'alto.
2. Tirando le due gambe una vicino all'altra (per chiudere eventuale spazio tra l'estremità del braccio e le gambe) serrare tutte le viti senza testa.

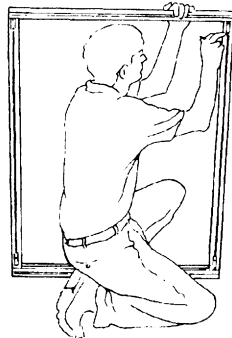

PARETE SUPERIORE

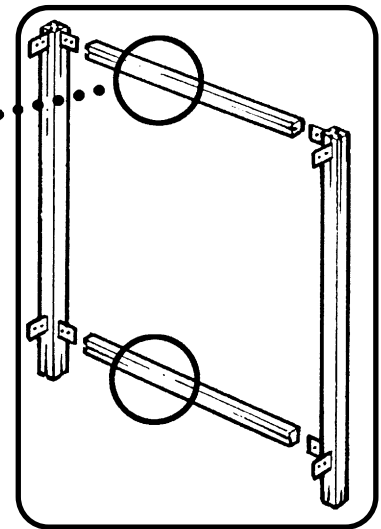
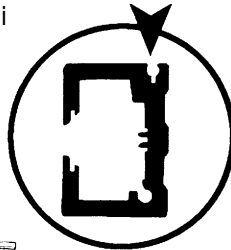

PARETE SUPERIORE

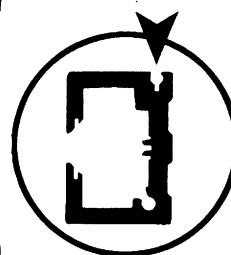

Stadio 3

1. Mettere un telaio d'estremità sul pavimento con le staffe rivolte verso l'alto e posizionare un lungo braccio al di sopra di ciascuna staffa (assicurarsi che la scanalatura piccola nel braccio sia rivolta verso l'alto).

2. Mettere o:

il telaio dell'altra estremità (se si sta montando un Big Bench da 1,0m o 1,5m).

oppure

il telaio centrale (se si sta montando un Big Bench da 2,0m o 2,5m).

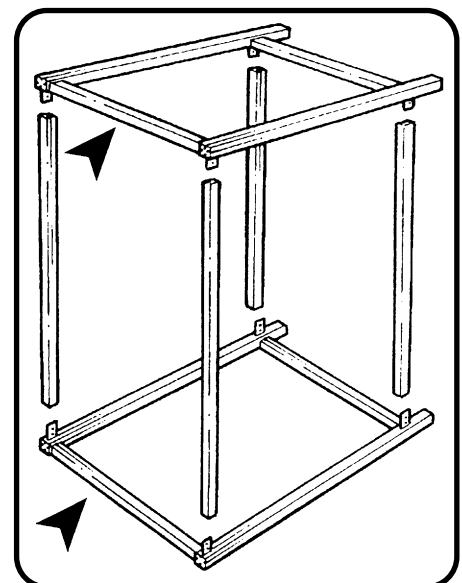
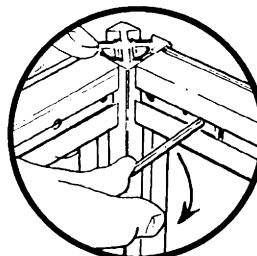

al di sopra dei bracci e serrare le viti senza testa assicurandosi che non vi sia spazio tra le estremità del braccio e le gambe.

3. **Soltanto Big Bench di 2,0, 2,5m o 3,0m**

Mettere il telaio in posizione verticale sui suoi piedi e posizionare i rimanenti bracci lunghi tra il telaio e quello rimanente d'estremità, serrare tutte le viti senza testa di nuovo assicurandosi che non vi siano degli spazi tra le estremità dei bracci e le gambe.

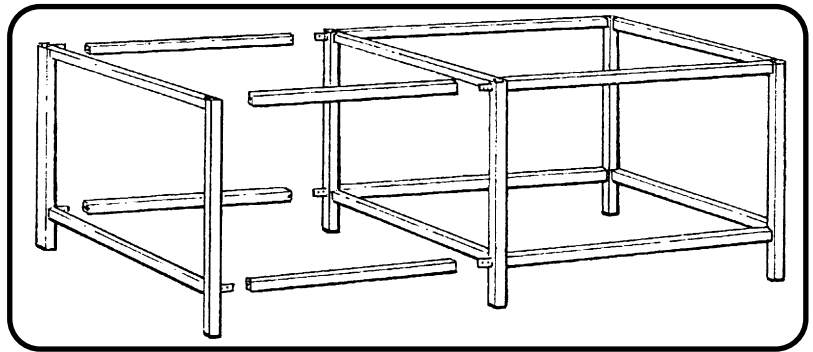

Stadio 4

1. Mettere l'estrusione di base sul bordo del banco in modo che le labbra pendono dal bordo anteriore delle gambe. Spingere i dadi quadri nell'incavo come illustrato e posizionare uno vicino a ciascuna gamba. Spingere le piastre di fissaggio del piano di lavorazione nelle loro scanalature e posizionarle a circa uguali distanze lungo l'estrusione di base.

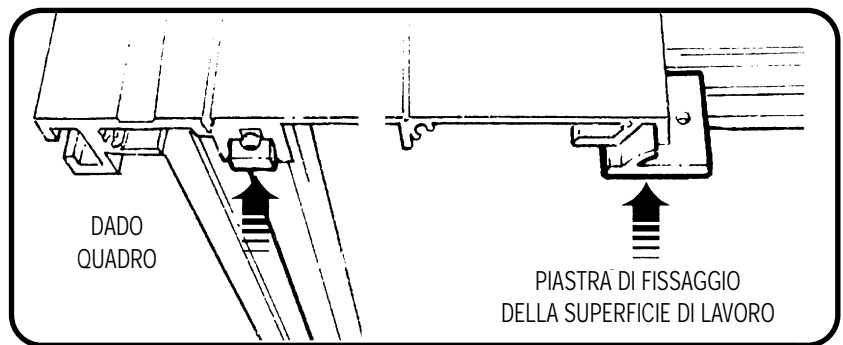
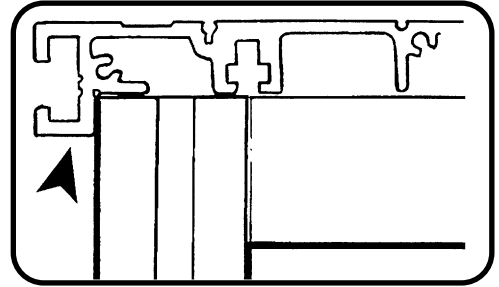

2. Usando una chiave esagonale di 5mm fissare l'estrusione di base in posizione sul banco con le relative morse e viti senza dado.

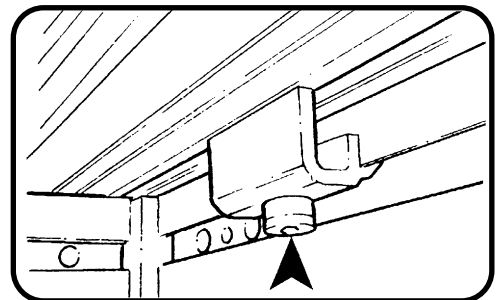

View from underneath

3. Fissare il meccanismo di solleva a mantieni a ciascuna estremità dell'estrusione di base con sei viti autofilettanti grandi su ciascuna estremità, non serrare completamente le viti a questo punto.

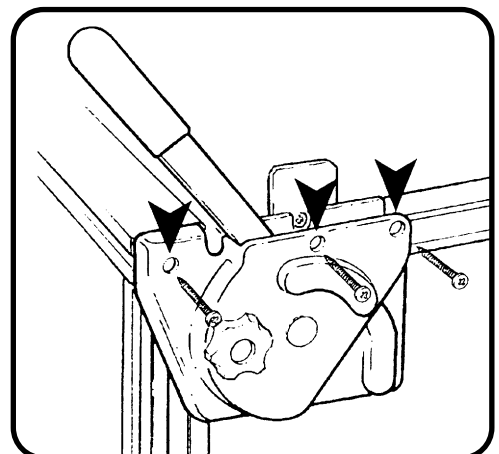

Stage 4 – cont'd

4. Fissare la superficie di lavoro in posizione usando
- Le viti grandi di fissaggio della superficie di lavoro come illustrato.
 - Le viti piccole per fissare le piastre di fissaggio della superficie di lavoro.

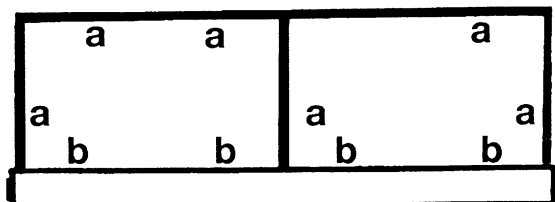
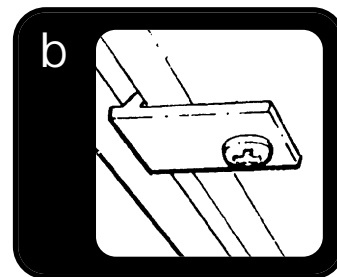
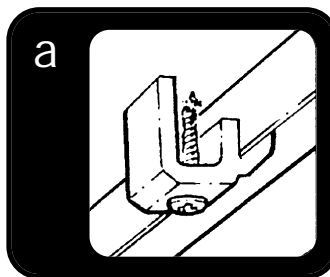

Veduta piana

Posizionare le staffe approssimativamente come illustrato.

5. Posizionare la taglierina Javelin sui due meccanismi solleva e mantieni facendo scivolare la lingua nella scanalatura all'interno dei cappucci dell'estremità del Javelin.

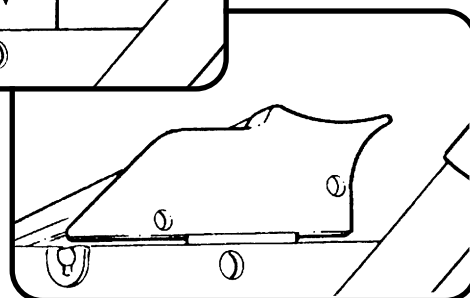
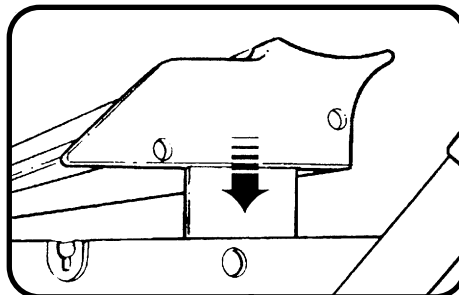
**NOTA:**

Il pomolo di attrito su ciascun meccanismo può essere regolato per mantenere il Javelin a qualsiasi distanza che rende accurato allineamento più facile quando in uso.

6. Muovere la testa di taglio verso una estremità del Javelin e premere la lama, regolare la posizione del meccanismo solleva e mantieni in modo che la lama scorra centralmente nella scanalatura sull'estrusione di base, serrare le tre viti per fissare il meccanismo solleva e mantieni. Ripetere l'operazione per l'altra estremità.

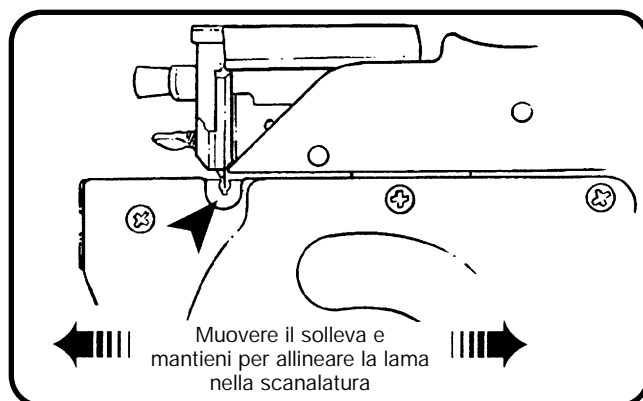

7. Posizionare il banco a posto ed usando una livella a bolla d'aria, regolare i piedi per assicurare che la superficie superiore del tavolo sia piana. Se il tavolo non è piano, particolarmente lungo la sua lunghezza, ci potrebbe essere difficoltà a mantenere il pezzo di lavoro in posizione lungo tutta la lunghezza di taglio.

8. Se si sta tagliando della carta sottile, controllare che il materiale possa essere afferrato lungo tutta la lunghezza del banco. Passare un piccolo pezzo di materiale di circa 25cm (10 pollici) di larghezza sotto la taglierina ed assicurarsi che sia tenuto in posizione, effettuare questo per la completa lunghezza.

Se la taglierina non afferra adiacente ad una gamba del banco, regolare il piede per sollevare leggermente quella parte del banco e provare di nuovo.

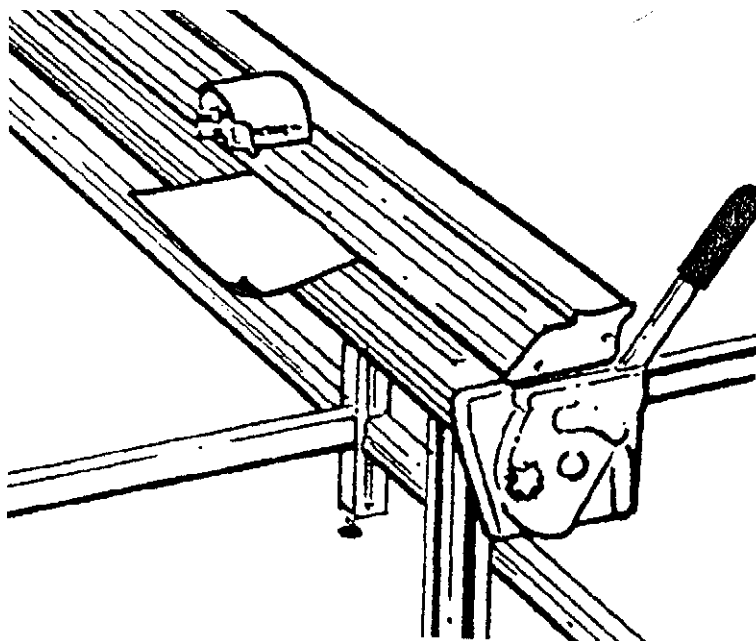

Se la carta non dovesse venire afferrata dalla barra di taglio fra le gambe, posizionare una staffa distanziale e avvitare il supporto sulla parte inferiore dell'estrusione di base. Posizionarla al centro dell'area che non fa presa e serrare la vite finché la carta non venga afferrata correttamente.

Verificare che l'intera barra di taglio faccia presa, aggiungere altre staffe distanziali e regolare se necessario.

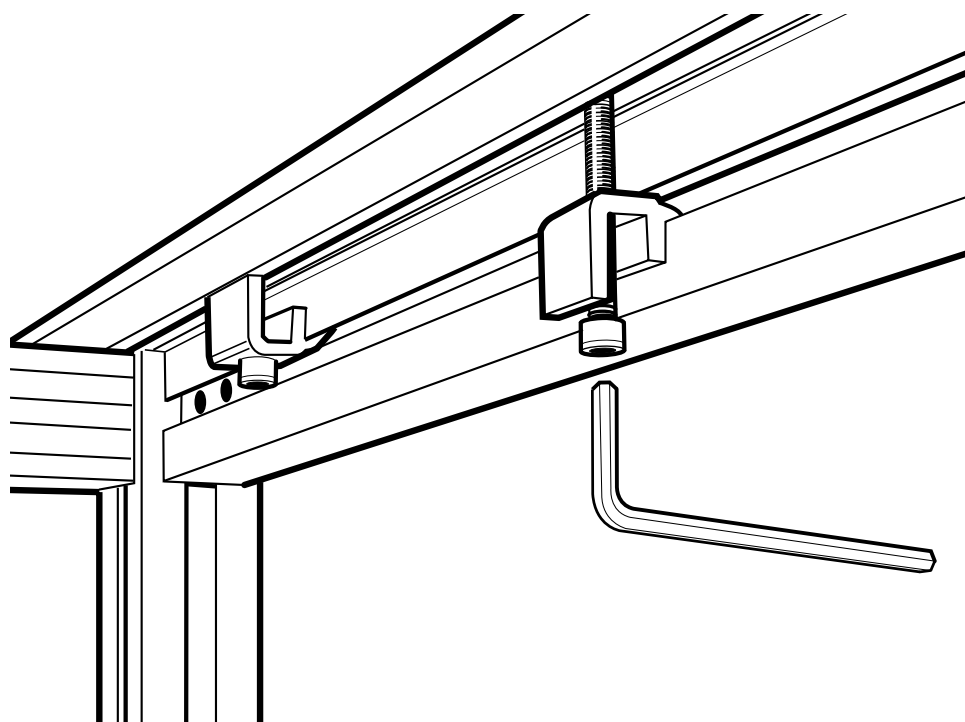



KEENCUT Limited

Baird Road, Willowbrook Industrial Estate,
Corby, Northamptonshire UK, NN17 5ZA.
Tel: +44 (0) 1536 263158 Fax: +44 (0) 1536 204227
E-mail: info@keencut.co.uk

KEENCUT INC. (North American Sales)

366-3560 Pine Grove Ave. Port Huron, Michigan,
48060 USA.
Toll Free: 1 800 240 KEEN (5336)
Tel: 1 (519) 652 0970 Fax: 1 (519) 652 0396
E-mail: northamericansales@keencut.com

www.keencut.co.uk

INSPIRED DESIGN - PRECISION ENGINEERING