

NVN  
1093

---

**PISTORIUS**

**MACHINE CO., INC.**

1785 EXPRESS DRIVE NORTH \* HAUPPAUGE, NEW YORK, U.S.A. 11788

PHONE: 516-582-6000

FAX NO: 516-582-6278

# **GENERATION II VEE NAIL™**

## **BRAND FRAME ASSEMBLY MACHINE**

### **VNA2, VNFA2, VNFA3**

### **OPERATING INSTRUCTIONS**

**&**

### **SERVICE MANUAL**

MODEL NO. \_\_\_\_\_

SERIAL NO. \_\_\_\_\_

NVN

**PISTORIUS GENERATION 2 VEE-NAILER™**  
**TABLE OF CONTENTS**

GENERAL MACHINE DESCRIPTION .....	i
MACHINE SPECIFICATIONS .....	ii
WARRANTY .....	iii
WARRANTY ADJUSTMENT TERMS .....	iii
RESPONSIBILITY OF INSTALLATION .....	iii
IMPORTANT NOTICE TO PURCHASER AND USER .....	iii
SECTION 1: STANDARD SAFETY DEVICES .....	1
SECTION 3: INSTALLATION .....	2
3.1 UNPACKING/INSPECTION .....	2
3.2 PLACEMENT .....	2
3.3 SEATING & ASSEMBLY .....	2
3.4 ELECTRIC CONNECTION .....	2
3.5 COMPRESSED AIR .....	2
SECTION 4: OPERATION .....	3
4.1 GENERAL VEE NAILER OPERATION .....	3
4.2 LOADING VEE NAILS .....	3
4.3 SETTING NAIL STOPS .....	3
4.4 SETTING CLAMPS .....	3
4.4.1 RABBET CLAMP .....	3
4.4.2 TOP CLAMP .....	4
4.5 SETTING FENCES .....	4
SECTION 5: SPECIAL OPERATION .....	4
5.1 JOINING WITH THE VNA-2 .....	4
5.2 JOINING WITH THE VNFA-2 AND VNFA-3 .....	5
5.3 TIPS ON USING THE VNFA-2 and VNFA-3 .....	5
SECTION 6: GLUE DISPENSER (OPTIONAL) .....	6
SECTION 7: MAINTENANCE .....	6
7.1 CHANGING NAIL DRIVER .....	6
7.2 LUBRICATING THE NAIL DRIVER .....	6
7.3 CLEANING THE DRIVER .....	6
7.4 REFILLING THE OILER BOWL .....	7
SECTION 8: TROUBLE SHOOTING .....	7
8.1 DIAGNOSING VNFA-2, VNFA-3 PROBLEMS .....	8
SECTION 9: ORDERING PROCEDURE .....	8
GENERIC PARTS LIST (parts common to all Generation II models) .....	9
VNA-2 PARTS(common to VNA-2 only) .....	11
VNFA-2 PARTS(common to VNFA-2 only) .....	12
VNFA-3 PARTS(common to VNFA-3 only) .....	12
FLOOR STAND PARTS .....	13

NVN

### GENERAL MACHINE DESCRIPTION

The Pistorius Generation 2 Vee Nail™ frame assembly machines are completely new designs. By use of the latest in computer aided design and computer controlled machining centers, it is now possible to have a frame assembly machine that is remarkable in its simplicity, reliability, and speed, yet reasonably priced.

The Vee Nail assembly system is specifically designed for high quality joining of unfinished or prefinished materials. Single or multiple nails are inserted into the bottom side of the frame material where they are not visible in most applications. This is done with a powerful cylinder and driver arrangement that presses the nail into the frame material while it is rigidly clamped on the work table against a pair of fences. Clamping is also performed with pneumatic cylinders. The fully automatic versions, the VNFA-2 and VNFA-3 utilize a PLC or programmable logic controller to fire the appropriate valves in the proper sequence and are capable of inserting up to four nails in up to two positions for the VNFA-2 or up to six nails in three positions for the VNFA-3. The main advantage of the VNFA-2 and VNFA-3 is the speed at which they operate. The operator merely has to place the two frame pieces against the work fence and depress the foot pedal: the machine does the rest at a very impressive speed. The automatic version or VNA-2 has a handle which serves as a means of positioning the nail as well as firing it. The clamps are foot pedal activated. This version has the unique ability of placing as many nails as desired in any position between the two stops. You can have best of both worlds by outfitting a VNFA-2 or VNFA-3 with the manual handle found on the VNA-2. A manual/automatic switch is provided to toggle between the two modes of operation.

Both versions have some features that make the machines very user friendly, for example, pressure control over both top and rabbet clamps. There is also a pneumatic toggle that controls a nail feed cylinder. Flipping this toggle retracts the cylinder allowing speedy reloading of nails. Changing from one nail size to another is simplified by a pair of wheels that, when rotated, alter the nail height. The wheels located in the nail loading port, have locking detents which provide positive height adjustment. The adjustable rabbet clamp has a pair of spring loaded serrated jaws that draw the mitered joint together resulting in a tight, professional looking joint. The fences can be quickly repositioned to accommodate 90°, 22½°, or 30° joints. The machine is also equipped with a low nail indicator light that illuminates when the nail level is too low.

NVN

**MACHINE SPECIFICATIONS**

Electrics (standard)	110 volt, 1 phase, 60 cycle 220 volt, 1 phase, 50
cycle Amps	
60 cycle	0.5 amps
50 cycle	0.5 amps
Power cord	3 prong grounded power cord, 8' long.
Air Consumption (3/8" ID minimum air line)	
VNFA-2, VNFA-3	6.0 cfm
VNA-2	5.0 cfm
Nail Lengths Available	1/4" (6mm), 3/8" (10mm), 1/2" (13mm), 5/8" (16mm)
Fence Height (standard)	3/4" (19mm)
Overall Size:	
Bench Model	12" wide(305mm) x 25" long(635mm) x 6 3/4" deep(171mm)
Floor Model	29" wide(737mm) x 30" long(762mm) x 43" high(1092mm)
Nail Magazine Capacity	250
Table Height From Floor:	
Bench Model	7 1/2"(191mm)
Floor Model	Adjustable from 35"(890mm) to 41"(1041mm)
Rabbit Clamping Force at 80 psi (5.4 Bar)	140 lbs
Top Clamping Force at 80 psi (5.4 Bar)	785 lbs
Nail Driving Force at 80 psi (5.4 Bar)	565 lbs
Minimum Height Moulding	3/8"(10mm)
Maximum Height Moulding	4"(101mm)
Minimum Frame Size (depending on width of molding)	3"(76mm) x 3"(76mm)
Maximum Frame Size	Unlimited
Minimum Spacing Between Nails	1/16"(1.5mm)
Maximum Spacing Between Nails	4"(101mm)
Minimum Width Moulding	3/8"(10mm)
Maximum Width Moulding (unlimited if rabbit clamp is removed)	4"(89mm)
Production Rate:	
Rate Will Vary With Operator and Size of Frame Being Assembled	
VNFA-2, VNFA-3	6 to 8 frames per minute
VNA-2	4 to 5 frames per minute
Maximum Number of Nails per Corner:	
VNFA-3	6
VNFA-2	4
VNA-2	Unlimited
Maximum Number of Nail Locations:	
VNFA-3	3
VNFA-2	2
VNA-2	Unlimited
Machine Weight (varies slightly depending on options)	
Bench Model	93 lbs(34 kg)
Floor Model	140 lbs(54 kg)
Air Pressure	80 psi (5.4 bar)
Actuation	Fully Shielded Footpedal

NVN

**WARRANTY (See back of invoice)**

The products covered herein are warranted, for a period of six (6) months from date of shipment, against defects in material and workmanship under normal use and service by Buyer. NO OTHER WARRANTIES ARE TO BE IMPLIED WITH RESPECT THERE-TO. The liability of Seller under its warranty is limited to adjustment, in accordance with the Warranty Adjustment Terms set forth below, for products which are found to be defective by Seller in the form in which they were originally shipped. In no event will Seller be liable for collateral, consequential or other damages of any kind or nature.

**WARRANTY ADJUSTMENT TERMS**

- (a) Adjustments will be limited to claims which are presented promptly after the product is found to be defective, and within the aforesaid warranty period.
- (b) All products claimed to be defective will be subject to an inspection and test by Seller. Normally, Seller will request return of products for inspection and testing. However, Seller reserves the right to make inspection and test on buyer's premises. Returns are to be made only as and if authorized in writing by Seller.
- (c) Buyer will pay all packing, inspection, labor, and transportation costs involved. Credit for the transportation costs will only be issued by Seller provided adjustment subsequently is allowed.
- (d) No adjustment will be allowed for products which have been subjected to abuse, improper installation or application, alteration, accident or negligence in use, storage, transportation or handling; nor for products on which original identification markings have been removed, defaced or altered.
- (e) Final determination as to whether any adjustment is allowable, and as to the extent thereof, rests with the Seller. Full adjustment, if allowed, will normally be replaced in kind on an exchange basis. Pro rate adjustment, if allowed, will be made by the issuance of credit. In all cases, however, Seller reserves the right to make adjustment by repair, replacement or credit.
- (f) Replacements for products found subject to adjustment, whether new or repaired, will be shipped F.O.B. city of destination with transportation charges prepaid by Seller.

**RESPONSIBILITY OF INSTALLATION**

Buyer shall install machinery purchased from Seller at Buyer's cost and expense, unless otherwise expressly stipulated, in writing: At the request of Buyer, Seller will recommend competent engineers to supervise the installation and to instruct the Buyer in the proper operation of the machinery and equipment. During such period of supervision and instruction, such personnel shall be deemed to be employees of the Buyer who shall pay the wages, remuneration, board and traveling expenses of such personnel. Seller's recommendation of such personnel shall not make Seller liable, directly or indirectly, in any manner whatsoever, for any damages resulting from any act of commission, or omission or any misfeasance, on the part of any of said personnel.

**IMPORTANT NOTICE TO PURCHASER AND USER**

All material contained herein is based on tests and information we believe to be reliable, but the accuracy or completeness thereof is not guaranteed. Neither seller nor manufacturer shall be liable for any injury, loss or damage, direct or consequential arising out of the use or the inability to use the product described herein. Manufacturer offers inspection by buyer and user of product prior to shipment from factory with adequate notice. **BEFORE USING, USER SHALL SOLELY DETERMINE THE SUITABILITY OF THE PRODUCT FOR HIS INTENDED USE AND USER ASSUMES ALL RISK AND LIABILITY WHATSOEVER IN CONNECTION WITH STRICT COMPLIANCE WITH FEDERAL, STATE AND LOCAL HEALTH AND SAFETY ORDINANCES TO ITS INTENDED USE.**

NVN

## **SECTION 1: STANDARD SAFETY DEVICES**

Safety at Pistorius is always a major concern and all Generation II Vee Nailers are equipped with the following safety devices.

### **A. Grounded Outlet**

- On all models, each unit is equipped with a three prong grounded outlet for safety.

### **B. Pneumatic Lockout**

- On all models, a pneumatic lockout is provided to physically lock the incoming air supply off

### **C. Work Area Guard**

- On all models, a clear plexiglass guard is secured to the fences and deters the operators hands from being accidentally caught under clamps.

## **SECTION 2: SAFETY RULES**

### **READ CAREFULLY BEFORE ATTEMPTING TO OPERATE THE UNIT**

1. NEVER ATTEMPT TO OPERATE OR SERVICE THE MACHINE UNLESS THOROUGHLY INSTRUCTED ON ITS SAFE AND PROPER USE.
2. DO NOT ALLOW POWER CORD OR CABLES TO LAY ON THE FLOOR IN THE WAY OF PASSING PERSONNEL. IT COULD CAUSE A TRIP HAZARD.
3. MAKE SURE THE ELECTRIC RECEPTACLE IS PROPERLY GROUNDED.
4. DON'T ABUSE CORD. NEVER YANK IT TO DISCONNECT FROM RECEPTACLE. KEEP CORD FROM HEAT, OIL, AND SHARP EDGES. HAVE DAMAGED OR WORN POWER CORD REPLACED IMMEDIATELY.
5. AVOID DANGEROUS ENVIRONMENT. DO NOT EXPOSE ELECTRICAL EQUIPMENT TO RAIN. DO NOT USE IN PRESENCE OF FLAMMABLE LIQUIDS OR GASES.
6. KEEP THE FLOOR, MACHINE, AND SURROUNDING AREA CLEAN AND FREE FROM SCRAP, SAWDUST/CHIPS, OIL AND GREASE TO AVOID THE DANGER OF SLIPPING.
7. WHEN LEAVING THE WORK AREA FOR ANY EXTENDED TIME (LUNCH BREAK, ETC), TURN THE MACHINE OFF.

## SECTION 3: INSTALLATION

### 3.1 UNPACKING/INSPECTION

Upon receipt, check the machine and shipping container for any damage. Report any transportation damage to the delivering carrier and indicate same on the bill of lading, and request an immediate inspection for assessment of damage. Claim should then be entered with the carrier. In the event of any damage or shortage we are willing to assist you in every way possible in collecting claims for loss or damage. This willingness on our part does not make us responsible for collection of claims or replacement of the material.

### 3.2 PLACEMENT

After unpacking, select a suitable location, allowing enough room around the machine for safe unobstructed work flow (material handling), cleaning and maintenance.

### 3.3 SEATING & ASSEMBLY

If the machine is purchased without the optional floor stand (i.e. Bench Model), it is important that the machine be placed on a sturdy table or bench that is capable of supporting the entire weight of the machine. Be sure the four rubber skip pads are in place underneath the machine. These will prevent the machine from "walking" during operation.

If the optional floor stand is added to the machine, assemble the floor stand as per the instructions included. After the machine and floor stand are assembled, level the machine using the leveling pads included with the floor stand. When finished the machine should not wobble or rock. The floor stand model is capable of being swiveled 180° to accommodate upright operation or invert the machine for easy servicing. This is done simply by loosening the two quick release handles that lock the two clamp collars on the side of the machine and rotate the machine to the desired position. Lock the two clamp collars when desired position is reached. Included with the floor stand is a pair of work supports that attach to the side of the machine with the socket cap screws included. The top of the work supports should be flush with the top of the machine work table.

### 3.4 ELECTRIC CONNECTION

The machine simply plugs into a standard 110 volt or 220 volt grounded single phase receptacle. Be sure the receptacle is in good working condition and is properly grounded. **NEVER REMOVE THE GROUNDING PRONG FROM THE POWER PLUG.** Also, be sure that the power cord does not obstruct any walkways. If applicable, use only three wire extension cords that have three prong grounding type plugs and a three pole receptacle that will receive the supplied plug. Replace damaged or worn cord immediately. **DO NOT ATTEMPT TO REPAIR POWER CORD.**

### 3.5 COMPRESSED AIR

Route a compressed airline to the machine. **CAUTION;** If a rubber hose is used be sure that it does not lay on the floor in the path of normal operator movement. It should not be allowed to cause a fall. It is recommended that the compressed airline drop from overhead. The airline connection should be made with a quick disconnect fitting to allow for positive lockout disconnect of the machine from the air source when performing adjustments, cleaning, maintenance, etc. On machines equipped with the optional airline filter, regulator and lubricator, make the air connection to the incoming end of the unit mounted on the side of the machine. On machines not so equipped, air connection is made directly to the air lockout or other marked and identified inlet.

**CAUTION: WHEN AIR PRESSURE IS INTRODUCED TO THE MACHINE, THE CLAMPS AND NAILING FIXTURE MAY IMMEDIATELY MOVE TO THEIR HOME POSITIONS. THEREFORE, USE EXTREME CAUTION TO STAND CLEAR OF THE MACHINE ON INITIAL STARTUP.**

## SECTION 4: OPERATION

### 4.1 GENERAL VEE NAILER OPERATION

After completing the installation procedure as described in Section 3, a number of steps must be performed before it is possible to begin joining. These steps apply to the VNFA-2, VNFA-3, and VNA-2. There are additional steps that may be required but are different depending on which machine is used and will be described in subsequent sections.

### 4.2 LOADING VEE NAILS

The loading operation is simple and quick in the Generation II Vee Nailers. Simply flip the air toggle marked "NAIL FEED" to the back position and the nail feed cylinder retracts to allow the nails to be loaded. Position a strip of Pistorius brand V-Nails® with the corner of the nails pointing towards the back of the machine, sharpened end facing up, and place the strip in the nail track making sure that the nail height adjustment is set to the proper nail height. If the nail height is not set properly, rotate the two adjusting wheels until the proper position is reached. The adjusting wheels have four discrete positions corresponding to the four different nail sizes. The bottom-most is for a 5/8" nail, the next position is for a 1/2" nail, and so on. When the height is set properly, the nails should be slightly above the edge of the nail track. After the nails are placed in the track, flip the air toggle to the forward position and the nail feed cylinder will extend to exert pressure behind the strip of nails.

### 4.3 SETTING NAIL STOPS

The two graduated stops located at the rear of the machine are used to define the limits of the nailing fixture travel. They are marked "OUTSIDE NAIL" and "INSIDE NAIL" and correspond to the nail closest to the outside edge of the frame and the nail closest to the inside edge of the frame, respectively. The VNFA-3 has an additional stop marked "MIDDLE NAIL". The scales located adjacent to the stops are used to determine the position of both the outside and inside nails. For example, setting the inside nail stop to 1 1/4" will place a nail 1 1/4" from the outside corner of the frame when measured along the miter.

To reset the position of a stop, simply loosen the quick release handle and slide the stop to the desired position and tighten the handle. A special case applies to setting the outside nail position of the VNFA-2 and VNFA-3. Since the nailing fixture is constantly applying force to the outside nail stop, loosening the stop will cause the nailing fixture to push all the way back. For this reason, the VNFA-2 and VNFA-3 are provided with an indexing toggle marked "INDEX FORWARD". When this toggle is switched to the forward position, the nailing fixture is indexed to the inside nailing position. In order to set the outside nail position, use the index toggle switch to move the nailing fixture to the inside nailing position and then reset the outside nail stop. Do not release the index toggle until the outside nail stop has been set and the handle tightened. The VNFA-3 has a third stop called "MIDDLE NAIL" that allows a nail to be inserted between the outside and the inside nail. It is set in the same fashion as the outside and inside stops. It is important that the middle stop be set between the outside and inside stops or the machine will not function properly.

### 4.4 SETTING CLAMPS

In order to achieve a good quality joint, it is essential that both the top clamp and rabbet clamp are set correctly. Setting the clamp involves both adjusting the clamp position to suit the moulding profile and setting the clamp pressure to suit the moulding material.

#### 4.4.1 RABBET CLAMP

The rabbet clamp has a series of holes which allow it to be quickly adjusted. This is done by lifting the



NVN

rabbit clamp clear of the retaining screw and resetting the clamp so that the clamp jaws are less than 1" from the moulding. The clamp cylinder has a 1" stroke which means there are usually two hole positions in the clamp that will work. The furthest hole will result in the clamp being furthest away from the moulding and is usually a better choice because it allows more room for the frame to be removed after assembly. Adjust the clamp pressure with the regulator marked "RABBIT CLAMP PRESSURE".

#### **4.4.2 TOP CLAMP**

The top clamp is adjusted via two lock handles; one handle locks a transverse slide that is used to position the clamp pad over the moulding, the other handle is used to adjust the height of the clamp pad over the moulding. To adjust the transverse slide, loosen the lock handle and slide the clamp so that the pad is directly above the desired area of the moulding, then tighten the lock handle. To adjust the height of the clamp pad, loosen the knob enough so that the clamp post slides freely and position the pad so that it is no more than 1" above the moulding and then tighten the lock handle. Be sure that the tip of the lock handle aligns with one of the holes in the side of the clamp post. This will insure that the post is locked positively and will not slide. Adjust the top clamp pressure by use of the regulator marked "TOP CLAMP PRESSURE". In general, the harder the material being joined, the more top clamp pressure is required. After the clamps are adjusted, they can be tested to see how the material clamps. Flip the power switch on the front of the machine to the "ON" position (switch will light up when power is on). Insert two pieces of frame against the fence as if to make a joint and step on the foot pedal (ON THE VNFA-2 and VNFA-3, THE OUTSIDE NAIL SELECTOR (GREEN) SWITCH MUST BE SET TO "0" FOR CLAMP ONLY MODE). If the clamps do not clamp properly, it will be necessary to readjust them. If the joint appears to be satisfactory when clamped, no adjustment is needed and the machine is ready to join.

#### **4.5 SETTING FENCES**

The fences are set at the factory to produce 90° corners, however the fences can easily be reset to produce 22½° and 30° corners as well. To do this, loosen the retaining screw that secures the fence to the work table and remove the fence. The fence has two locating pins on the bottom that mate with any of the three sets of holes. Place the fence in the appropriate set so that both pins go into their accompanying holes, and tighten the retaining screw. Do the same for the opposite fence. The attached guard must also be reset to compensate for the change in angle. This is done by removing the wingnut on top of the guard, relocating the stud to the proper hole, and then securing the wingnut.

***UNDER NO CIRCUMSTANCE SHOULD THE PROTECTIVE GUARDS BE REMOVED.***

### **SECTION 5: SPECIAL OPERATION**

#### **5.1 JOINING WITH THE VNA-2**

After the machine has been adjusted as described in Section 4, it is now ready to begin joining. Operating the VNA-2 is straightforward and simple. First, turn the power on by flipping the red rocker switch in the front of the machine (switch will light up when the power is on). Then place the two pieces of moulding against the fence. **IT IS VERY IMPORTANT THAT THE LEFT MOULDING BE PLACED AGAINST THE LEFT FENCE AND SLID UNTIL THE CORNER TOUCHES THE RIGHT FENCE FOLLOWED BY THE RIGHT MOULDING. IT WILL BE DIFFICULT TO ALIGN THE JOINT UNLESS THIS IS DONE.** When the joint looks good, depress the footpedal to activate the clamps.

***CAUTION: KEEP HANDS AND FINGERS AWAY FROM CLAMPING AREA BEFORE DEPRESSING FOOTPEDAL. THESE CLAMPS CAN CAUSE SERIOUS INJURY TO THE OPERATOR.***

With the moulding clamped properly, position the nailing fixture by moving the firing handle back and forth. When the nailing fixture is in the proper position, fire the nail by pressing the firing handle to the

NVN

left (or right, if handle is set up for left-handed user). This will fire one nail at the designated position. Releasing the handle returns the nail driver and the machine is ready to fire again. Another nail can be inserted directly beneath the first by pressing the firing handle again without changing the position. This "stacking" effect gives a very strong joint but should be used with caution as the nails can be pushed through the top of the moulding if the moulding is too thin. The fixture can be repositioned to insert as many nails as desired. After the nails are inserted, release the footpedal to deactivate the clamps and remove the moulding.

### **5.2 JOINING WITH THE VNFA-2 AND VNFA-3**

Joining with the VNFA-2 requires very little effort on the part of the operator. First, turn the power on by flipping the red rocker switch in the front of the machine (the switch will light up when the power is on). Then select the number of nails in the joint using the red and green selector switches. The green switch determines the number of nails in the outside position (position closest to the outside of the frame) and can be either one or two. The red switch determines the number of nails in the inside position (position closest to the inside of the frame) and can also be either one or two. **THE GREEN SWITCH MUST BE SET TO EITHER ONE OR TWO NAILS IN ORDER TO FIRE ANY NAILS AT ALL. IF IT IS SET TO ZERO, NO NAILS WILL FIRE.** Setting the red switch to zero means that nails will only be inserted in one position. Setting the green switch to zero puts the machine in CLAMP ONLY mode which allows the operator to clamp the moulding without firing a nail. It is a good idea to do this before attempting to make the first joint of a new moulding to insure the moulding clamps properly. Unlike the VNA-2, the VNFA-2 fires the nails automatically when the footpedal is pressed and released.

The VNFA-3 has a third selector switch for the middle nail position. It is a yellow selector switch and can be set to 1 or 2 to insert one or two nails in the middle nail position.

After the selector switches are set and the clamps are adjusted as described in Section 4.4, place the two pieces of moulding against the fence. **IT IS VERY IMPORTANT THAT THE LEFT MOULDING BE PLACED AGAINST THE LEFT FENCE AND SLID UNTIL THE CORNER TOUCHES THE RIGHT FENCE FOLLOWED BY THE RIGHT MOULDING. IT WILL BE DIFFICULT TO ALIGN THE JOINT UNLESS THIS IS DONE.** When the joint looks good, depress the footpedal and then release it. The machine will then automatically activate the clamps and fire all the nails. When the nailing is finished, the clamps will automatically release and the frame can be removed. The machine is now ready to perform the cycle again.

***CAUTION: KEEP HANDS AND FINGERS AWAY FROM CLAMPING AREA BEFORE DEPRESSING FOOTPEDAL. THESE CLAMPS CAN CAUSE SERIOUS INJURY TO THE OPERATOR.***

### **5.3 TIPS ON USING THE VNFA-2 and VNFA-3**

1. If the machine is being used with the optional floor stand, it is often more efficient to use tilt the machine up so that the frame pieces are inserted from the top. This is particularly true when joining large frames where the operator tends to get in the way of the frame.
2. Setting the stop for the outside nail requires the nailing fixture to be indexed to the forward position before loosening the stop handle. This is done with the INDEX FORWARD switch on the right side of the work table. Push this switch to the forward position allowing the nailing fixture to move to the inside nail stop and make the adjustment to the outside nail stop. Be sure to hold the switch forward while making the adjustment; the switch will automatically return when it is released.
3. When the machine is in CLAMP ONLY mode (i.e., the green selector switch set to "0"), stepping on the footpedal activates the clamps; releasing the footpedal releases the clamps. When the machine is set up to fire nails, the footpedal must be depressed and then released in order for the machine to cycle.

NVN

4. When using a VNFA-3, it is important that the middle stop be set between the outside and inside nail stops.

#### **SECTION 6: GLUE DISPENSER (OPTIONAL)**

The model GL-CA glue dispenser allows the operator to accurately dispense the correct amount of glue for extremely strong wood joints using Pistorius "Dura-Bond" water soluble wood glue. The units 'ball point pen' design effectively eliminates messy squeeze bottles, paint brushes and open glue pots by sealing off the system when not in use. This also prevents the glue from drying out. Mounting the glue pen to the top of the V-nailer keeps the operators hands free to perform the joining operation.

To install GL-CA glue dispensing system, simply mount the unit to the floor stand with the hardware provides and tap off the filter/regulator/lubricator to provide air pressure to the system. Regulate the pressure in the glue tank to no greater than 15 psi. With the air pressure off, fill the tank with Pistorius "Dura-Bond" glue and secure the fill plug at the top of the tank. Once air pressure is supplied, the unit is ready to dispense glue.

#### **SECTION 7: MAINTENANCE**

***CAUTION: UNLESS OTHERWISE SPECIFIED, DISCONNECT BOTH THE AIR AND POWER CORDS BEFORE ATTEMPTING ANY MAINTENANCE PROCEDURE. FAILURE TO DO SO COULD RESULT IN ELECTRICAL SHOCK AND/OR SERIOUS INJURY FROM CLAMPS AS WELL AS POSSIBLE DAMAGE TO THE MACHINE.***

##### **7.1 CHANGING NAIL DRIVER**

When the tip of the driver no longer has sharp corners, it should be replaced. To do this, remove the panel from the bottom of the machine (it may be easier to flip the machine over to gain access to the bottom). Remove the eight screws that secure the drive cylinder cap to the drive cylinder and pull off the drive cylinder cap. Be sure not to lose the rubber O-ring. With a small screwdriver, press on the tip of the driver from the top of the machine to extract the driver/piston assembly from the drive cylinder. Loosen the set screw on the end of the piston shaft and remove the driver retaining bolt from the piston. Remove the old driver and slide a new driver through the hole of the driver retaining bolt. Secure both pieces onto the end of the piston shaft and tighten set screw.

##### **7.2 LUBRICATING THE NAIL DRIVER**

Oil the nail driver and driver guide by placing four or five drops of a light-weight machine oil in the oiling hole located on the top of the driver guide. This should be done at least once a day before a production run and more often during heavy use.

##### **7.3 CLEANING THE DRIVER**

After prolonged use, the driver may become contaminated with dirt and grime. This can result in nails becoming jammed in the driver guide. To clean the driver, follow the procedure in section 6.1 to remove the driver from the machine. Any build up of dirt can be scraped off with a razor blade. Finish by cleaning the driver with a solvent such as acetone. Follow section 6.1 to re-install.

NVN

**7.4 REFILLING THE OILER BOWL**

When the oiler bowl is empty, unscrew the bowl to remove it from filter/oiler/regulator assembly. Clean out any moisture that may have accumulated and refill with PNEUMALUBE OIL. Screw the bowl back onto the filter/oiler/regulator assembly.

**SECTION 8: TROUBLE SHOOTING**

Repairs, other than those described here, should be performed only by trained, qualified personnel. Call Pistorius for further information.

PROBLEM	CAUSED BY	SOLUTION
1. VNFA-2, VNFA-3 does not cycle when footpedal is depressed.	-Power switch not on or electric or air not connected.  -Outside nail selector (green switch set to "0").  -Bad PLC controller	-Flip power switch to "ON" position. Plug in air and electric.  -Set green selector switch to "1" or "2".  -Call PISTORIUS
2. Nails are not pressed all the way into the moulding.	-Not enough air pressure.  -Nail driver not adjusted high enough.  -Reed switch sensor on drive cylinder too low.	-Increase incoming air pressure with regulator on filter/oiler/ regulator. -Raise nail driver height (see Section 6.1) -Raise reed switch on drive cylinder.
3. VNFA-2, VNFA-3 fires one nail and then stops functioning.	-Reed switch on drive cylinder too high. (red light on switch should be lit when driver is up)  -Nail is not being inserted far enough into the moulding causing the fixture to jam.	-Lower reed switch on drive cylinder.  -See solution to Problem 2.  -See special note below on diagnosing problem.
4. V-nails are jamming inside driver guide.	-Build-up of foreign matter in the driver guide. -Worn driver -Nail height is not set for the correct nail	-Clean driver guide so it is free of any dirt or glue build up. -Replace driver (Section 6.1) -Reset nail height to match nail being used. (Section 4.2)
5. Frame corner is open on top.	-Top clamp pressure is low causing frame to lift.  -Top clamp pad is too soft.	-Increase top clamp pressure  -Replace with harder clamp pad.

NVN

### 8.1 DIAGNOSING VNFA-2, VNFA-3 PROBLEMS

Due to the automated nature of the VNFA-2 and VNFA-3, there are a number of switches that are essential to the operation of the machine. Specifically, there are switches that provide information to the PLC (programable logic controller) concerning the position of the nailing head and the position of the nail driver. Each switch is connected to the PLC at a numbered location. When a particular switch is "on" or closed, a light on the switch will be lit as well as a light on the corresponding location on the PLC. Once the foot pedal is depressed and released, the sequence of operation is as follows:

OPERATION	INPUT STATUS
1. Clamps activated, first nail is fired (driver in "up" position).	1. "Driver up" switch on (yellow switch located at top of drive cylinder, position 006 on PLC)
2. Driver retracted (driver in "down" position)	2. "Driver down" switch on (yellow switch located at bottom of drive cylinder, position 008 on PLC)
3. Nailing head indexed to next position (middle nail position or inside nail position)	3. "Nail head indexed" switch (threaded switch mounted to middle and inside nail stops, position 007 on PLC)
4. Fire next nail (either middle or inside nail)	4. "Driver up" switch on (yellow switch located at top of drive cylinder, position 006 on PLC)
5. Driver retracted (driver in "down" position)	5. "Driver down" switch on (yellow switch located at bottom of drive cylinder, position 008 on PLC)
6. If machine is VNFA-3 set to 1-1-1, (1 outside, 1 middle, 1 inside nail), repeat steps 3 to 5	6.
7. Once all nails are fired clamps will release, cycle is finished.	7. "Driver down" switch stays on (yellow switch located at bottom of drive cylinder, position 008 on PLC)

If the machine "hangs up" or delays for a few seconds and then releases the clamps without inserting all the nails, a fault condition has occurred implying that the input switches were not closed according to the above sequence. Simple observation of how the machine behaves can determine which input switch is at fault. If the problem cannot be determined, call Pistorius for further assistance.

### SECTION 9: ORDERING PROCEDURE

The procedure for ordering repair parts is as follows:  
Order part by:

Machine Model Number (located on the machine name plate)  
Machine Serial Number ( " " " " " " " )  
Part Number (located on the parts list)  
Part Name ( " " " " " " )  
Quantity (located on the parts list)

# PISTORIUS

## MACHINE CO., INC.

AUG/99F

PARTS LIST  
 VNA2, VNFA2, VNFA3  
 (Parts common to all Generation II models)

REF#	PART#	DESCRIPTION
1	6T32A04K	QUICK RELEASE HANDLE
2	1/2-20X20SC	SOCKET CAP SCREW 1/2-20 x 1-1/4
3	NVN00051	ADJUSTABLE STOP POINTER
4	CS-2121	4 WAY AIR TOGGLE W/BF1 FITTINGS
5	557-1104-203	LOW NAIL INDICATOR LIGHT (RED)
6	NAR2000-N01	PANEL AIR REGULATOR
7	146260	PANEL PRESSURE GAGE
8	4X200	IDEX MOMENTARY SWITCH
9	E22XBG2	3 POS. ROTARY SWITCH (RED)
9*	E22XBG3	3 POS. ROTARY SWITCH (GREEN)
9*	E22XBG4	3 POS. ROTARY SWITCH (YELLOW)
10	NVN000130	NAIL PLATAFORM
11	NVN00034	NAIL PUSHER PAD
12	NVN00129	NAIL TRACK / CYLINDER MOUNT/ NEW
13	NVN00037	STOP PLATE / INSIDE NAIL (RABBET)
14	NCDJ2B10500C805	DOUBLE ACTING CYLINDER W/REED SWITCH
15	NVN00128	NAIL TRACK SUPPORT
16	AA-335-6	BUSHING 1/4" x 5/16" x 5/8"
17	10-32x3SS	SET SCREW 10/32 x 3/16"
18	NVN00071R	RIGHT HAND NAIL ADJUSTMENT WHEEL
19	10-32x5/8SC	SOCKET CAP SCREW 10-32 x 7/8"
20	LC-035F-6	COMPRESSION SPRING .420 x 1-1/4"
21	6391K111	BUSHING 1/8 ID x 1/4 OD x 1/4"
22	NVN00137	SPRING RETAINER
23	6TA03K	QUICK RELEASE HANDLE / FEMALE THREADS
25	044-DXP	DOUBLE ACTING INDEX CYLINDER (5/8")
26	NVN00053	BEARING ROD AND INDEX CYL. MOUNT (FRONT)
27	NVN00061	BEARING ROD
28	* NVN00038	DRIVER ASSEMBLY
29	NVN00119	DRIVER GUIDE MOUNT
30	10-32x5/8SC	SOCKET CAP SCREW 10-32 x 5/8"
31	8-32x10SC	SOCKET CAP SCREW 8-32 x 5/8"
32	NVN00028	DRIVER GUIDE BLOCK / EDM
33	NVN00071L	LEFT HAND NAIL ADJUTMENT WHEEL
34	E2E-X2D1-N	INDUCTIVE PROXIMITY SENSOR 8MM 2 WIRE
35	NVN00036	SECOND NAIL ADJUSTABLE STOP /RABBET
36	NVN00047	RABBET JAW LINK SCREW
37	NVN00046	RABBET CLAMP MOUNTING BLOCK
38	FPS-1009	PANCAKE EXTENDED TOP CLAMP CYLINDER
39	1/4-20x2SC	SOCKET CAP SCREW 1/4-20 x 2"
40	NVN00078	RABBET CLAMP CYLINDER END COVER
41	1A824	LIGHTED ROCKER SWITCH

# PISTORIUS

## MACHINE CO., INC.

42	NVN00124	MACHINE CABINET / COVER # NVN00125
43	NVN00048	LEFT FENCE
44	10-32x16SC	SOCKET CAP SCREW 10-32 x 1"
45	NVN00049	RIGHT FENCE
46	10-32x16SC	SOCKET CAP SCREW 10-32 x 1"
47	NVN00045	ADJUSTABLE RABBET BAR ONLY (MEDIUM)
48A	29621	TOP CLAMP STAR KNOB ONLY (PLASTIC)
48B	NVN00041	TOP CLAMP HANDLE THREADED STUD ONLY
49	NVN00050	TOP CLAMP MOUNT / SUPPORT BAR SLIDE
50	NVN00039	TOP CLAMP CROSS BAR / HORIZONTAL
51	NVN00040	TOP CLAMP VERTICAL MOUNT POST
53	6-32x6SC	SOCKET CAP SCREW 6-32 x 3/8"
54	10-32xSC	SOCKET CAP SCREW 10-32 x 5/8"
55	10-32xSC	SOCKET CAP SCREW 10-32 x 1"
56	NVN0A034	HANDLE <del>PIVOT BAR</del>
57	FF-620-1 →	FLANGE BRASS BUSHING ←
59	NVN0A030	HANDLE PIVOT BEARING
60	1/2x10SB	SHOULDER BOLT 1/2 x 3/4"
61	NVN0A029	PIVOT BEARING MOUNT
62	SW292-ND	ELECTRIC CONFIRMATION SWITCH ← 4
63	NVN0A026	HANDLE MOUNTING BLOCK
64	B-34	HANDLE KNOB (BALL)
65	NVN0A025	PIVOT ARM
66	NVN0A027	VALVE STRIKER
67	1/2x10SB	SHOULDER BOLT 1/2 x 1"
68	1/4-28N	NUT 1/4 - 28
69	NJ04	INDEX CYLINDER LINKAGE (FLOATING)
70	KQH-07-34S	ELBOW AIR FITTING 1/4" OD, 1/8" NPT
71	NVN00053	BEARING ROD MOUNT (REAR)
72	NVN00089	CLAMP PAD MOUNTING BLOCK
73	NVN00093	CLAMP PAD ASSEMBLY (BLACK / BLUE) ← EA 460
74	3/8-16x8SC	SOCKET CAP SCREW 3/8-16 x 3/4"
75	NVN00076	REED SWITCH CLAMP BRACKET
76	NVN00121	DRIVER RETAINER NUT
77	NVN00088	PROXIMITY SENSOR MOUNTING BRACKET
78	NVN00126	LEFT CLEAR ACRYLIC GUARD
79	NVN00127	RIGHT CLEAR ACRYLIC GUARD X
80	E-10	HALL EFFECT SWITCH (CONFIRMATION)
81	FPS-507-C22	DRIVER PISTON 1" BORE
81*	FPS-507-C18	DRIVER PISTON 3/4" BORE (OLD)
82	632-S	FOOT PEDAL
83	MN00G049	FOOT PEDAL GUARD (ORANGE)
84	NVN00044	RIGHT / LEFT HAND RABBET JAW †
85	LC-032B-12	COMPRESSION SPRING †
86	NVN00134	JAW MOUNTING BAR ONLY (SHORT)
87	NVN00133	JAW MOUNTING BAR ONLY (STANDARD)
88	5/16x4SC	SHOULDER SCREW 5/16 x 3/8"
89	232-70D	DRIVER PISTON "O" RING
90	8-32x2SC	SOCKET CAP SCREW 8-32 x 1/2"

66mpo LCC FI-130DA PH#350-  
 TOM BLOCK FI-10-CON. # 20-

# PISTORIUS

## MACHINE CO., INC.

91	6391K258	DRIVE CYLINDER SLIDE BUSHING
92	NVN00122	DRIVE CYLINDER BODY ONLY (1" SHAFT)
93	9452K34	DRIVE PISTON FRONT "O" RING (1" SHAFT)
94	6391K281	DRIVE CYLINDER PISTON BUSHING
95	AS-042	DRIVE CYLINDER REAR COVER SEAL RING
96	1/4-20x3FH	FLAT HEAD SCREW 1/4-20 x 3/4"
97	10-32x3SS	SET SCREW 10-32 x 3/8"
98	NVN00031	DRIVE CYLINDER END COVER
99	KQL-07-34S	ELBOW AIR FITTING
100	10-32x8SC	SOCKET CAP SCREW 10/32 x 5/8"
101	NVN00077	RABBET CLAMP CYLINDER BODY
102	KQH-07-34S	STRAIGHT AIR FITTING
103	9691K23	END CUP SEAL
104	6391K212	RABBET CYLINDER BUSHING
105	NVN00079	PISTON ROD ASSEMBLY
106	9452K38	RABBET PISTON "O" RING #218
107	9452K117	END COVER SEAL
120	NVN00108	MIDDLE NAIL STOP FLAG
121	NVN00098	MIDDLE STOP CYLINDER BODY
122	BF	BARBED FITTING 10-23 THD - 1/8" OD HOSE
123	9452K21	PISTON SEAL 3/8 ID, 1/2 OD
124	6391K172	BUSHING 3/8 ID, 1/2 OD x 3/8"
125	NVN00110	MIDDLE NAIL STOP CYLINDER SLEEVE
126	9452K74	SEAL "O" RING
127	NVN00107	MIDDLE NAIL STOP PISTON
128	NVN00109	MIDDLE NAIL CYLINDER REAR COVER
129	6-32x6SC	SOCKET CAP SCREW 6-32 x 3/8"
130	9452K28	MIDDLE NAIL PISTON "O" RING

### FLOOR STAND

131	NVN00054	MACHINE PIVOT MOUNT
132	NVN00057	HEIGHT ADJUSTMENT STAND BAR
133	NVN00056	STAND LEG
134	3/8-16x8BH	BUTTON HEAD SCREW 3/8-16 x 1/2"
135	NVN00060	STAND FOOT
136	3/8-16x8SC	SOCKET CAP SCREW 3/8-16 x 1/2"
137	NVN00058	STAND CROSS BRACE
138	3/8-16FN	FULL NUT 3/8-16
139	3/8 - W	HEAVY WASHER 3/8 x 1/8"

---

NVN00100	MACHINE TOP TABLE
S-6479-1-VN	WORK SUPPORT MOUNT (RIGHT/LEFT)
98381A550	DOWEL PIN 1/4" x 2"
NVN00074	PLATAFORM GUIDE PIN



# PISTORIUS

MACHINE CO., INC.

NVN00125	MACHINE BOTTOM COVER
NVN00041	TOP CLAMP POST LOCKING STUD
1320	RIGHT ANGLE STRAIN RELIEF BUSH. (18/2)
1397	RIGHT ANGLE STRAIN RELIEF BUSH. (18/3)
9405K48	POLYETHYLENE BUMPER .190" HOLE
98381A508	DOWEL PIN 3/16" x 3/4"
9838AA477	DOWEL PIN 1/8" X 1 1/4"
NVN00035	ADJUSTABLE HOME STOP
NVN00067	CUSTOM FOUR STATION MANIFOLD
536Q	FOOT VALVE ELECTRIC SWITCH
S-6143-1-VN	RIGHT WORK SUPPORT
S-6143-2-VN	LEFT WORK SUPPORT
SY5140-LOZ	SOLENOID VALVE
NAC2010-N02	FILTER/REGULATOR/OILER
EXE-X2D1-N	INDUCTIVE PROXIMITY SENSOR 2 WIRE 8mm
E22XBG4	3 POS. ROTARY SWITCH OPERATOR (YELLOW)
E22B2	CONTACT BOLCK
TV-3SF	3 WAY TOGGLE VALVE (MANUAL / AUTOMATIC)
NVZ1120-3MZ-M5	MINI SOLENOID VALVE (VNFA2, VNFA3)
NVN00051	ADJUSTABLE STOP POINTER

# RABBET JAW ASSEMBLY

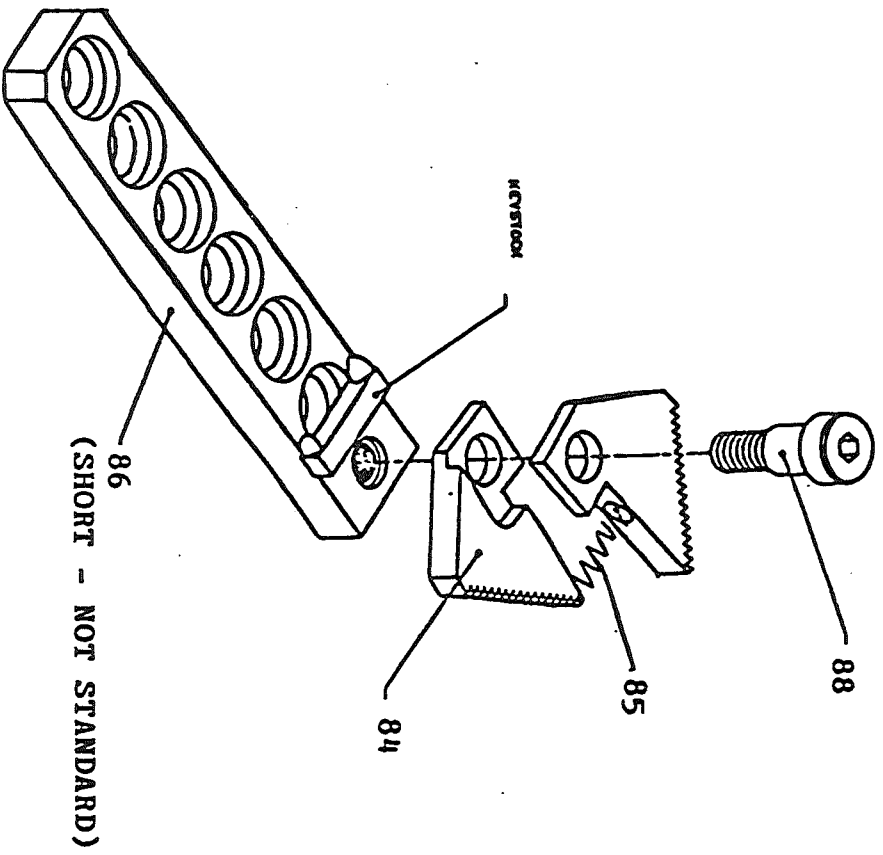

NVNO0133

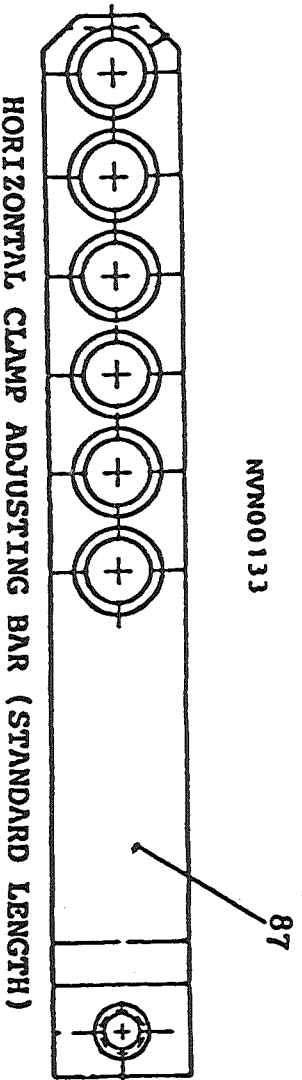

# DRIVE CYLINDER ASSEMBLY

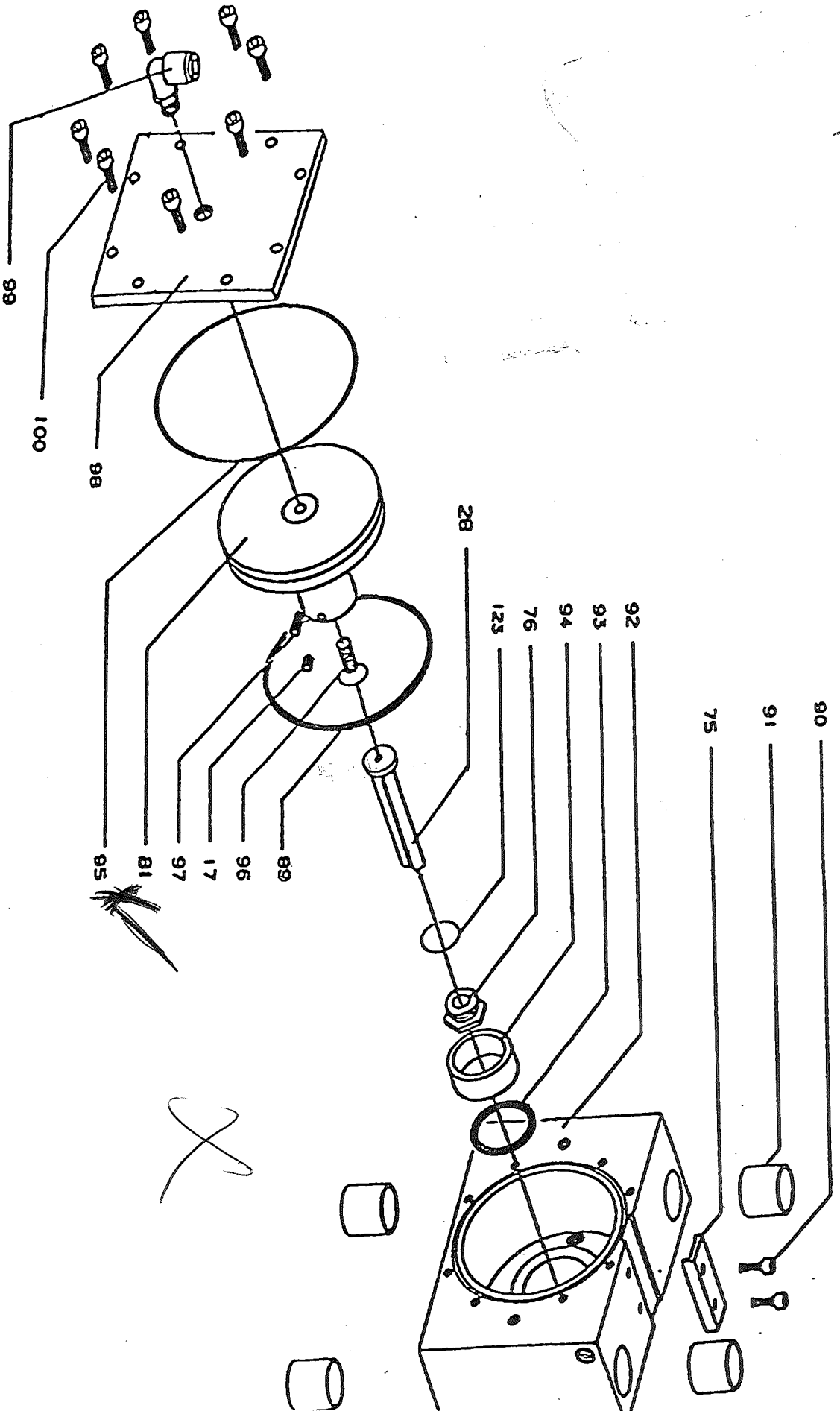

FIG. 2

RABBET CLAMP CYLINDER ASSEMBLY  
NVN00112

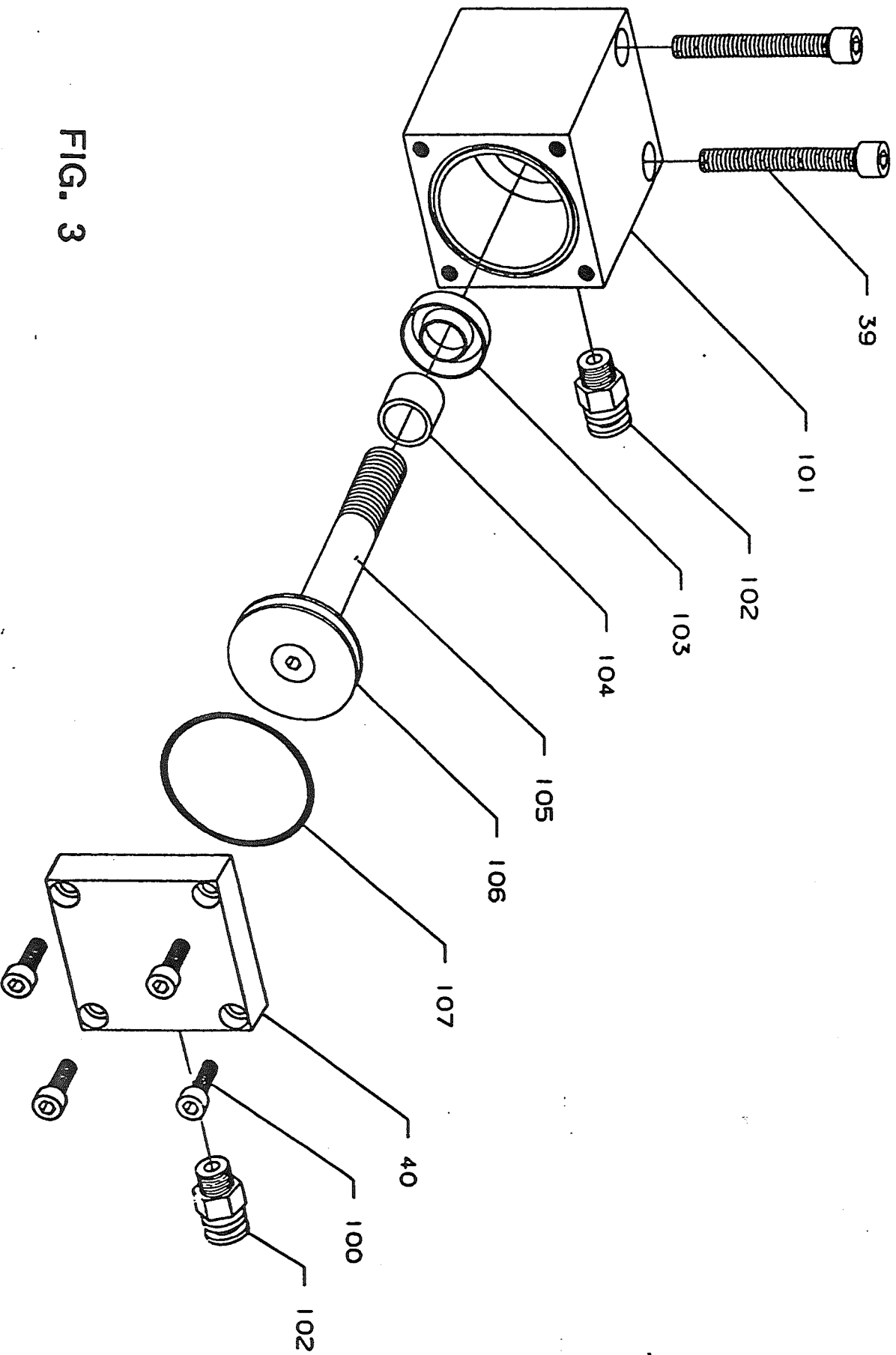

FIG. 3

MIDDLE NAIL STOP ASSEMBLY

NVNO0111

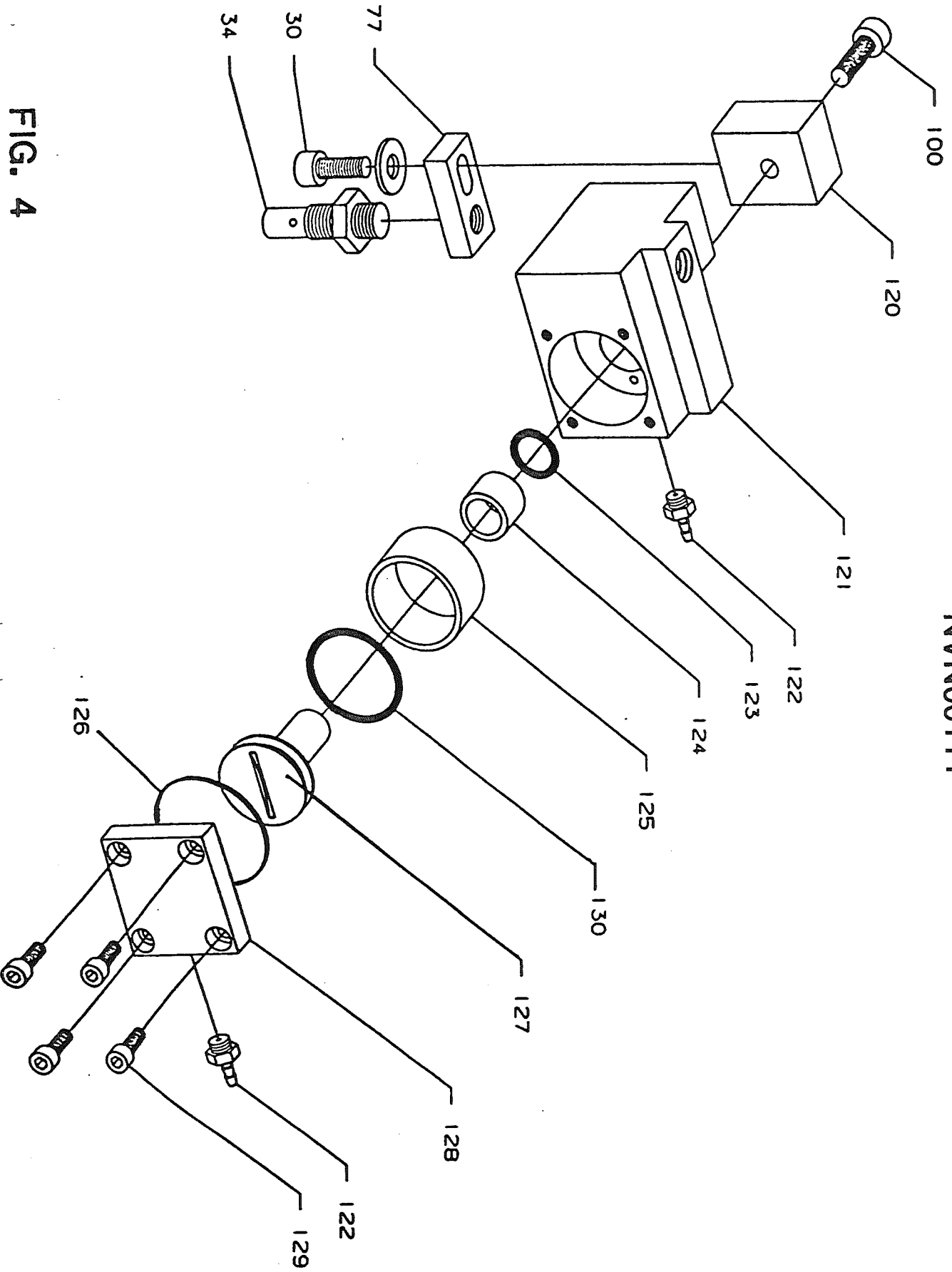
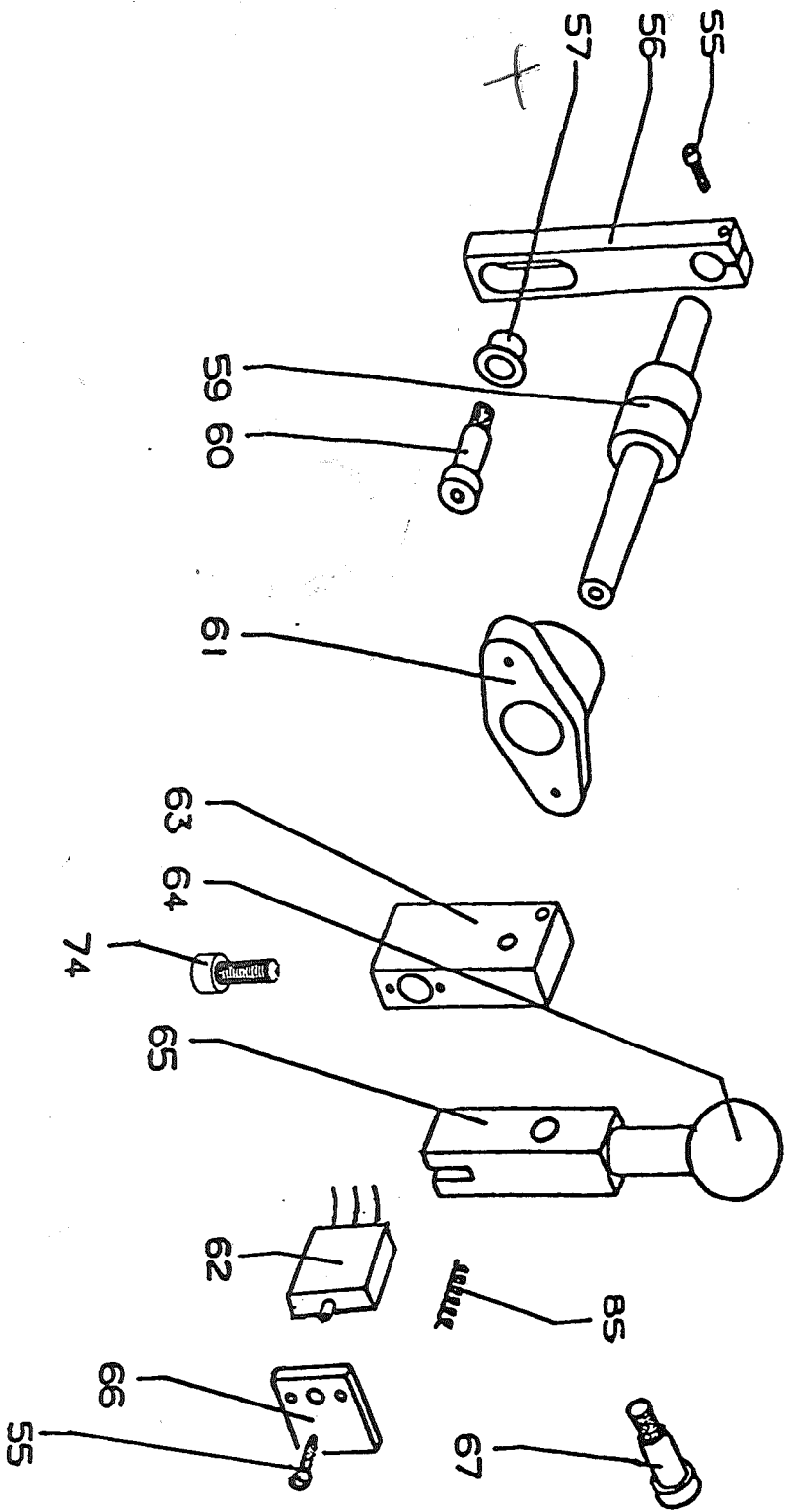

FIG. 4

# VNA-2 HANDLE ASSEMBLY



BOTTOM SECTION

VNFA3

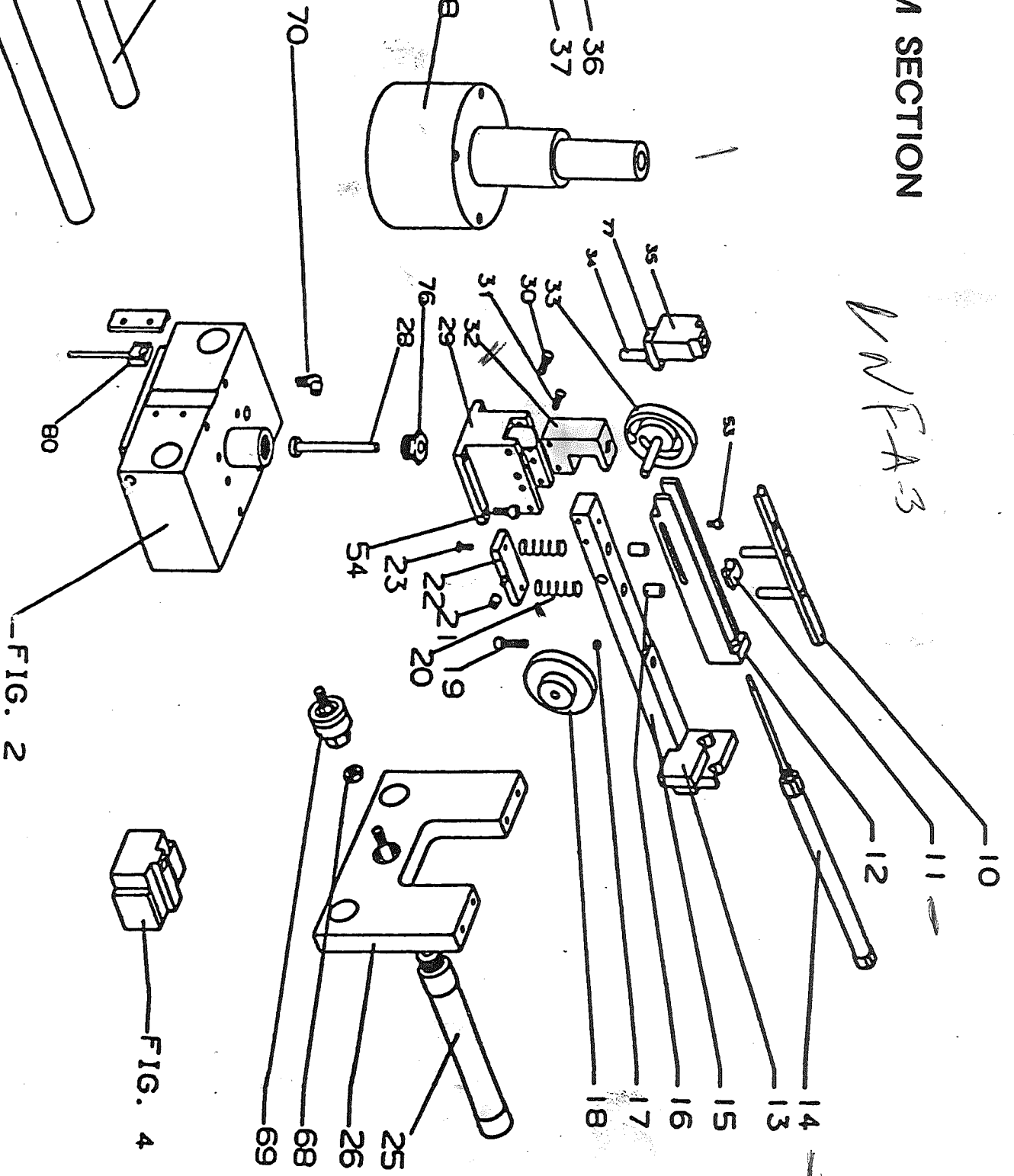
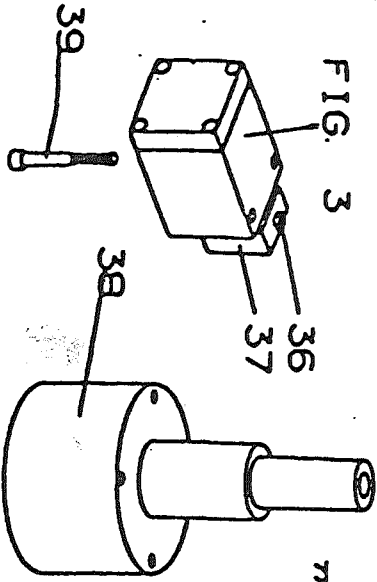
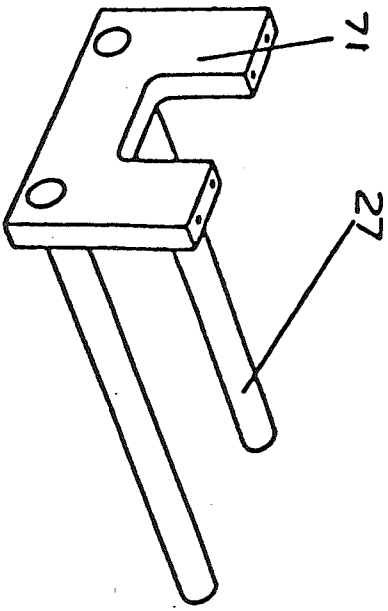

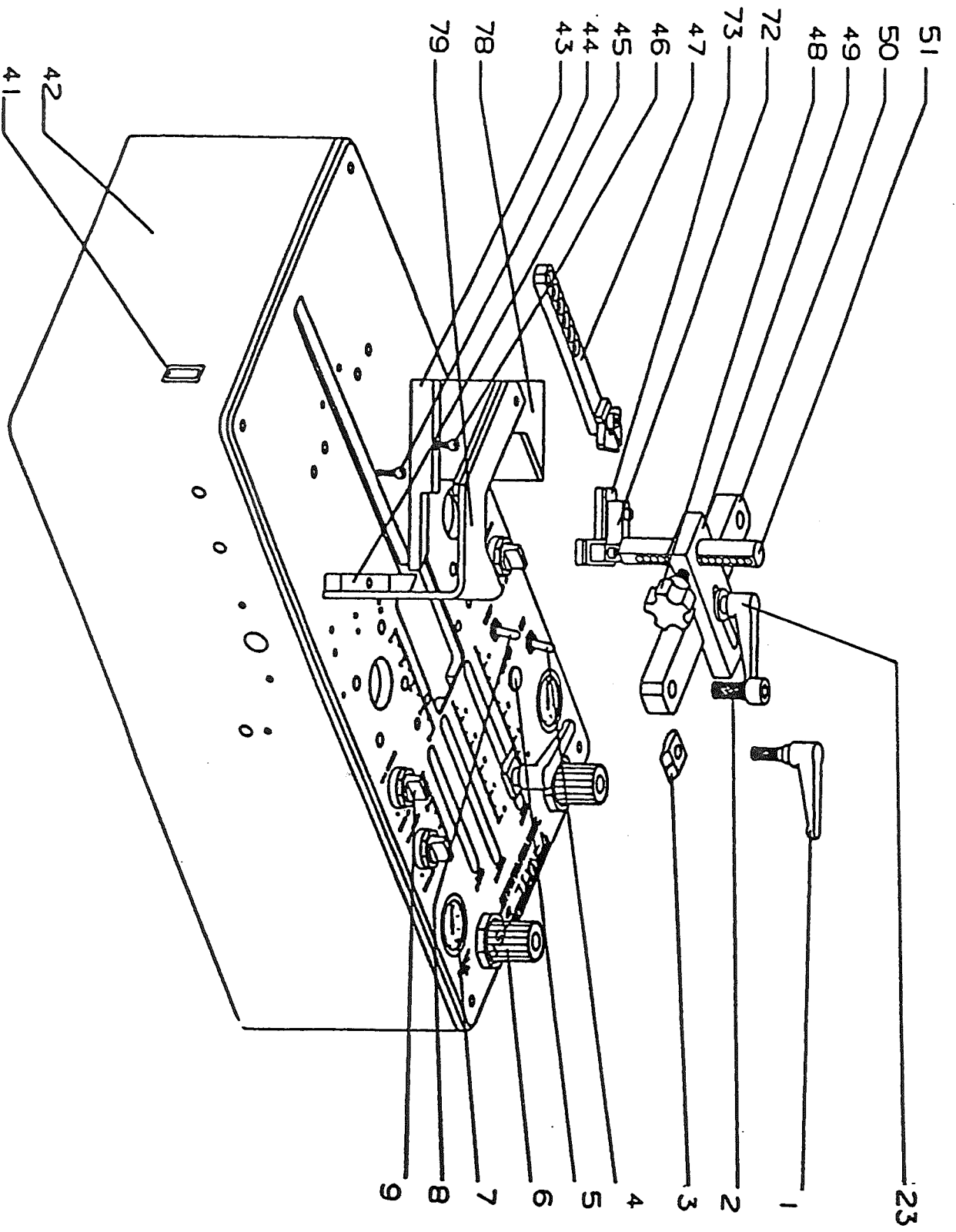



# PARTS BREAK DOWN OF FLOOR STAND

## ASSEMBLY # NVN00069

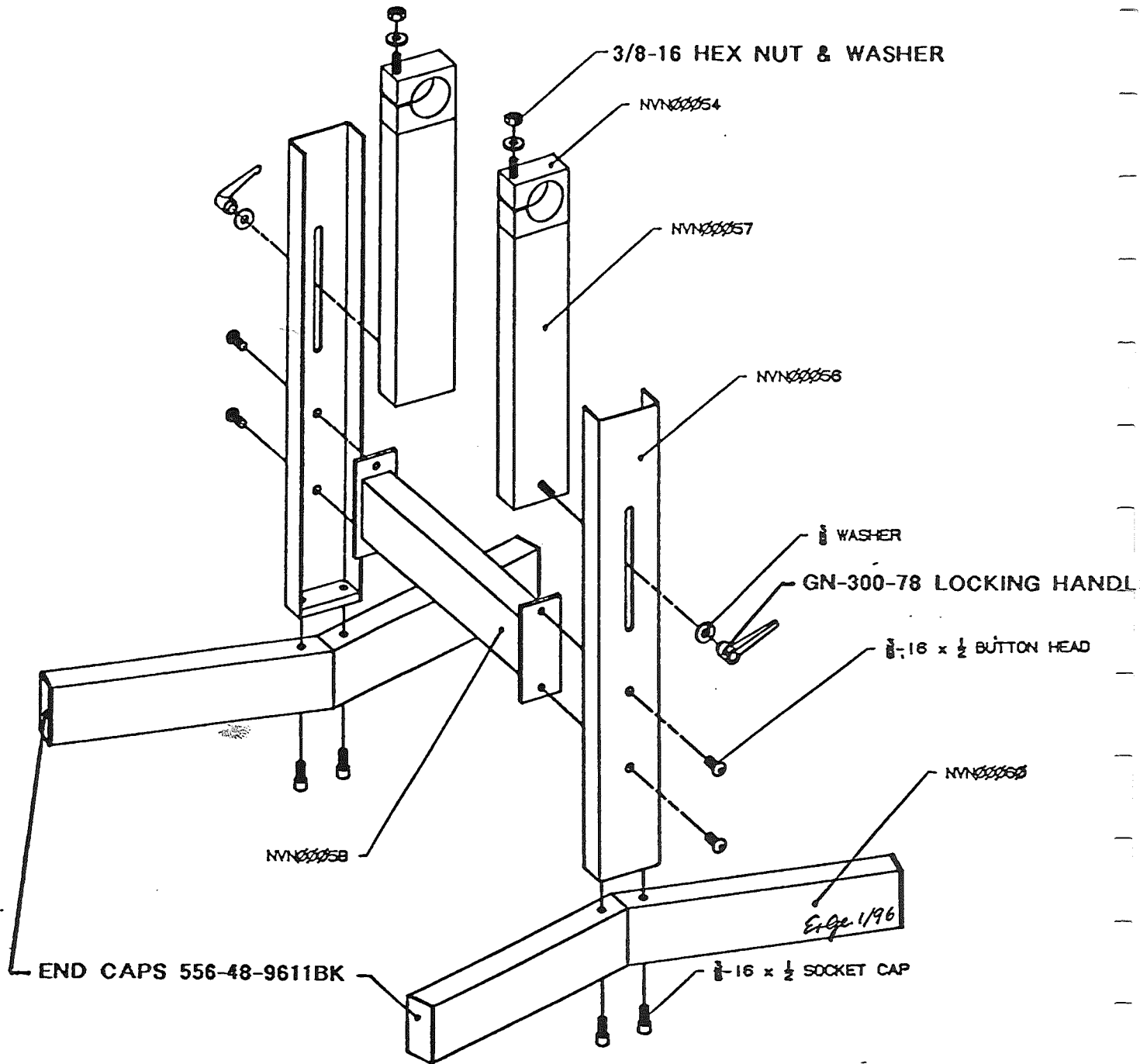

VNF00041  
 FRAME SUPPORT SLIDE BAR  
 MOUNT TO VNF00041 WITH  
 WING & WING BOLTS (3)

VNF00042  
 FRAME SUPPORT CLAMP BAR

VNF00040  
 FRAME SUPPORT EXTENSION  
 SECURE TO VNF00039 WITH  
 1/4"-16 x 1 ALLEN CAP SCREWS (2)  
 BOTH SIDES

VNF00039  
 FRAME SUPPORT MOUNT  
 SECURE TO MACHINE WITH  
 1/4"-16 x 1 1/2 ALLEN CAP SCREWS (2)  
 BOTH SIDES

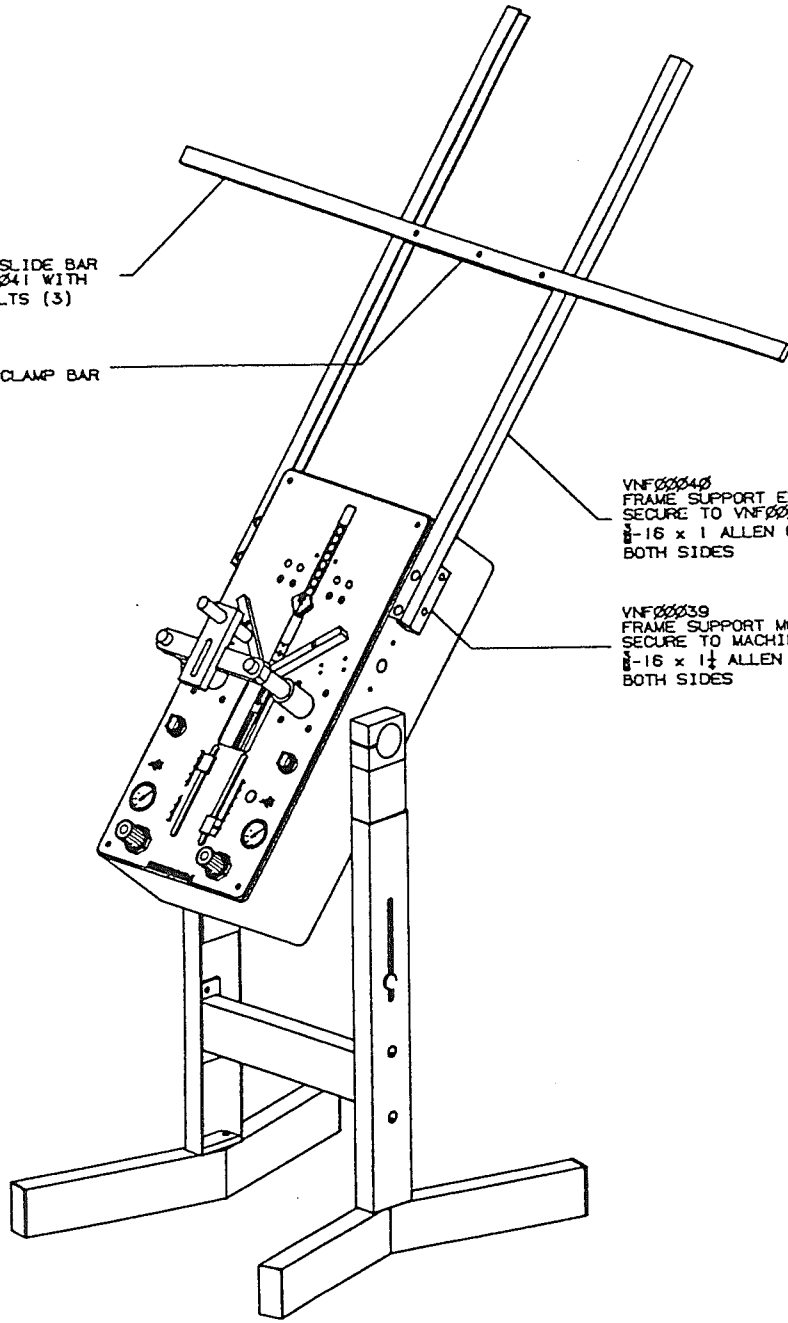

NAME:  
 FRAME SUPPORT ASSEMBLY

**PISTORIUS MACHINE CO., INC.**  
 1785 EXPRESS DRIVE NORTH, HAUPPAUGE N.Y. 11788, USA

CUSTOMER: -	
MACHINE: VNA-2, VNA-2, VNA-3	SCALE: 1:7
DATE: JANUARY 17, 1996	DRAWN BY: GAC
DWG. NO.: NVN00002	INVOICE NO: -
THIS IS A PROPRIETARY DRAWING, ALL DESIGN DETAILS ARE THE EXCLUSIVE AND CONFIDENTIAL PROPERTY OF PISTORIUS MACHINE CO.	

INSTALLED ON MACHINES  
WITH MANUAL OVER-RIDE  
OPTION

FIRING SWITCH  
D2SN-3M

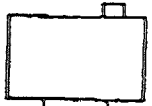

BLUE  
BLACK

16 POLE  
CONTACT  
BLOCK

- 1
- 2
- 3
- 4
- 5
- 6
- 7
- 8
- 9
- 10
- 11
- 12
- 13
- 14
- 15
- 16

BLACK

BLACK

WHITE

WHITE

WHITE

WHITE

WHITE

WHITE

WHITE

WHITE

WHITE

WHITE

WHITE

WHITE

WHITE

WHITE

GREEN

BLACK

WHITE

WHITE

WHITE

WHITE

WHITE

WHITE

WHITE

WHITE

WHITE

WHITE

WHITE

WHITE

WHITE

WHITE

WHITE

WHITE

WHITE

WHITE

WHITE

WHITE

WHITE

WHITE

WHITE

WHITE

WHITE

WHITE

WHITE

WHITE

WHITE

WHITE

WHITE

WHITE

WHITE

WHITE

WHITE

WHITE

ON/OFF SWITCH  
CARLINS SWITCH  
1AB24

WHITE

BLACK

BLACK

BLACK

MIDDLE STOP VALVE

INDEX VALVE

NAIL VALVE

TOP CLAMP VALVE

HORIZ. CLAMP VALVE

4 LIVES (4)

12

4 LIVES  
-MIS

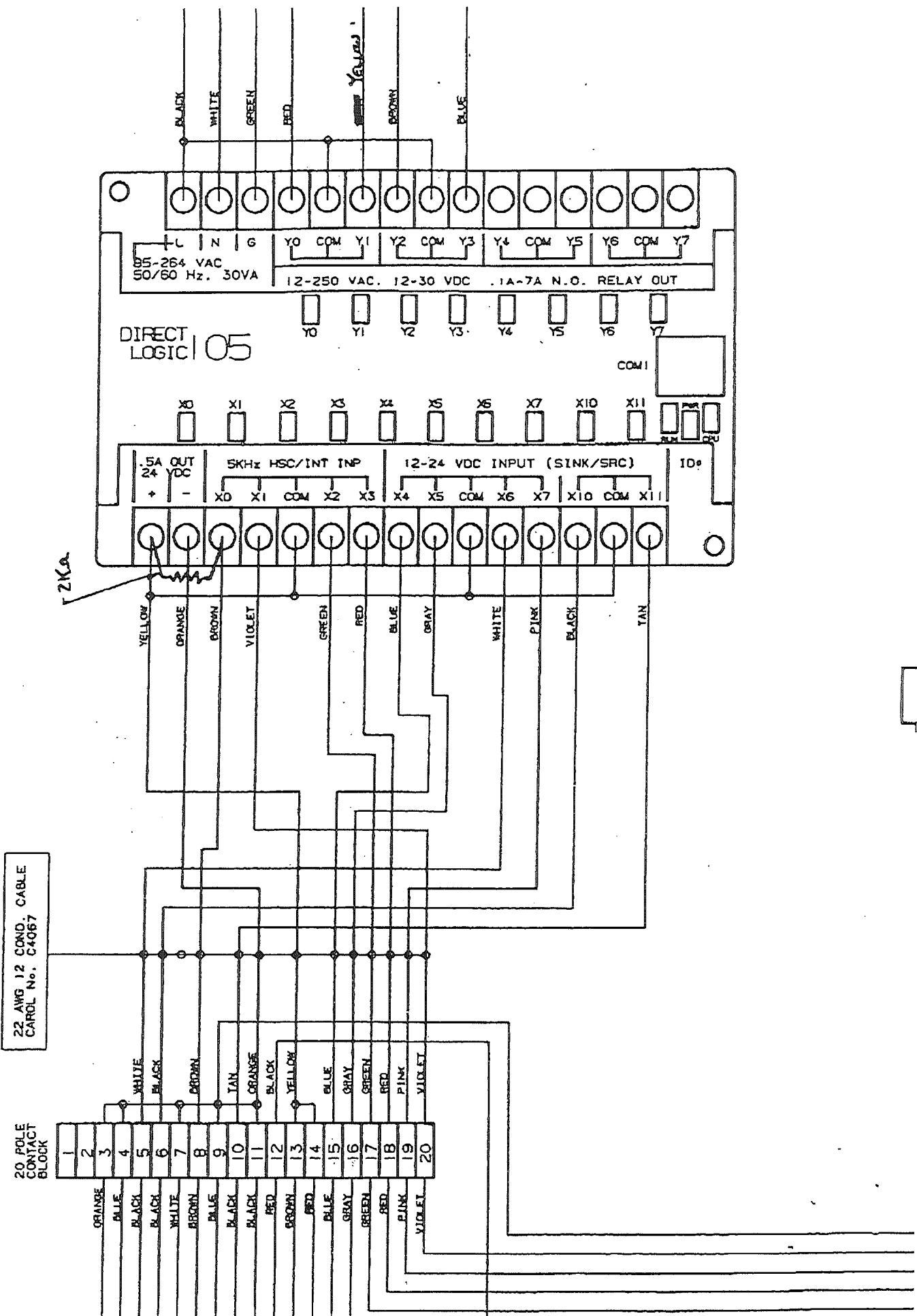

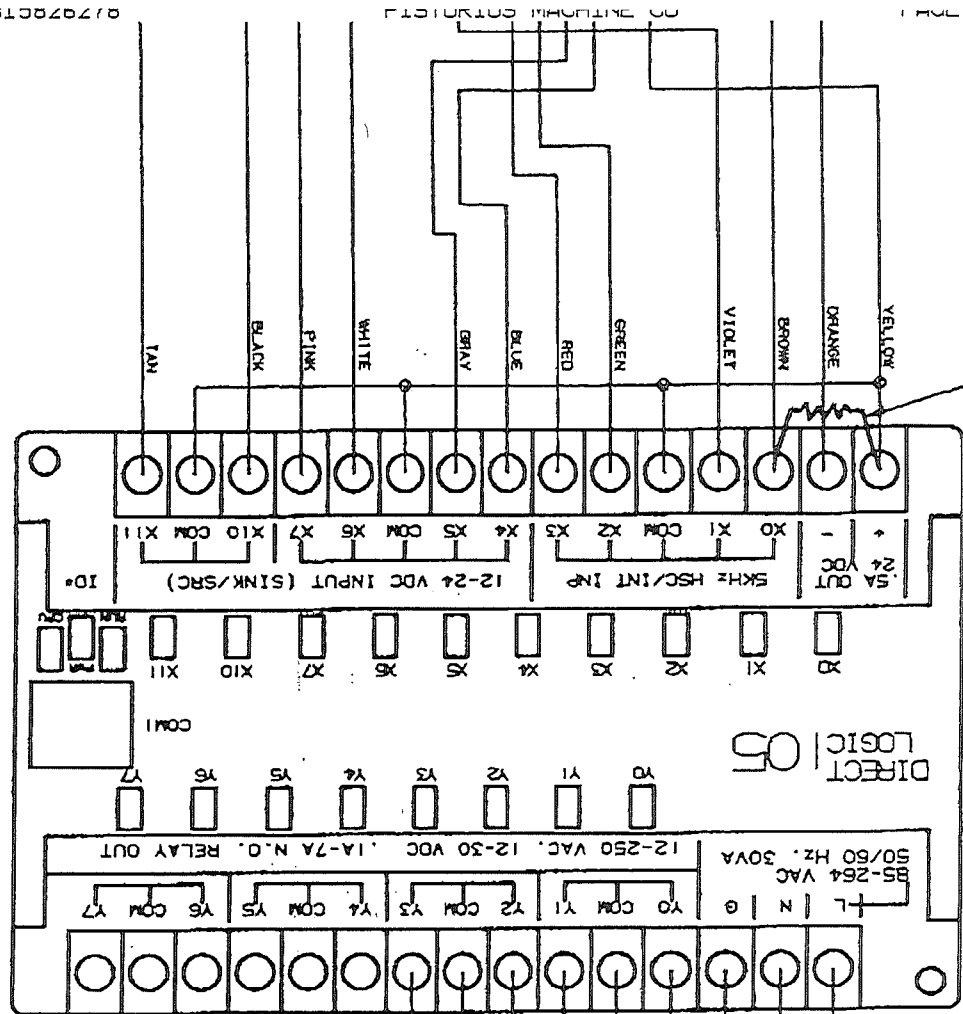
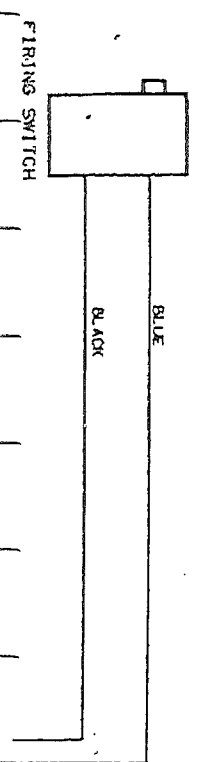

2KΩ

DIRECT LOGIC 05

22 AWG 8 COND. CABLE  
CAROL No. C4065

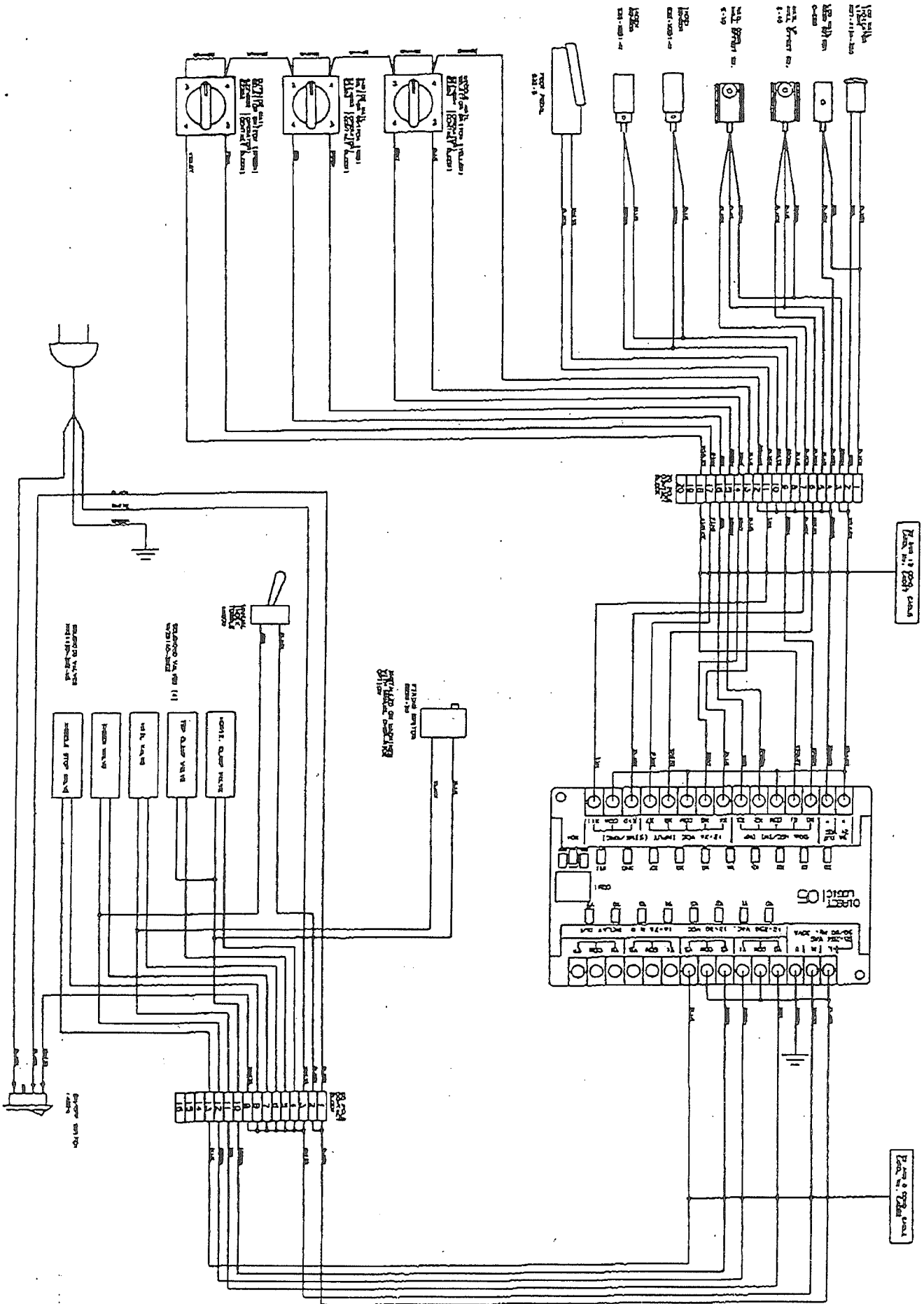

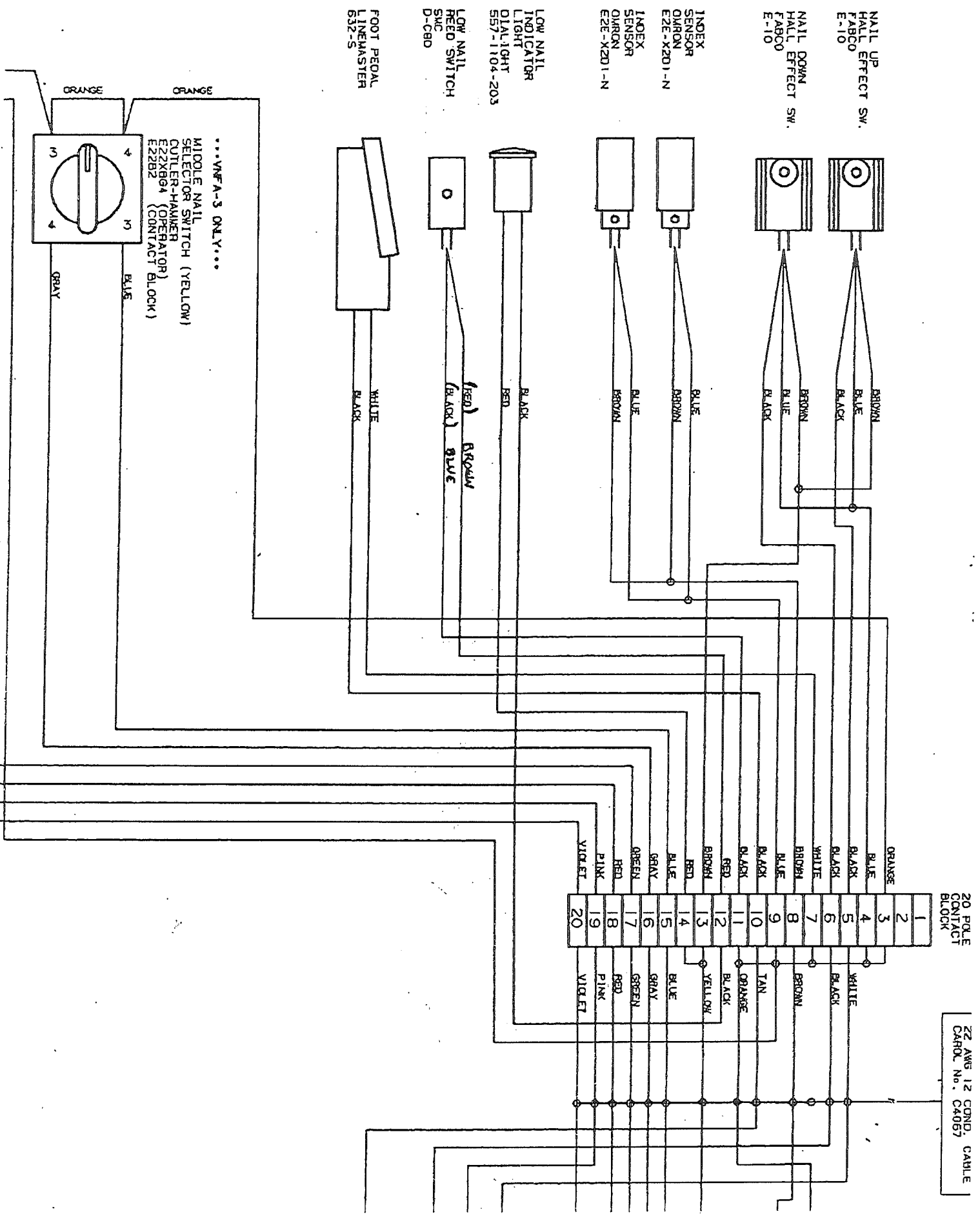

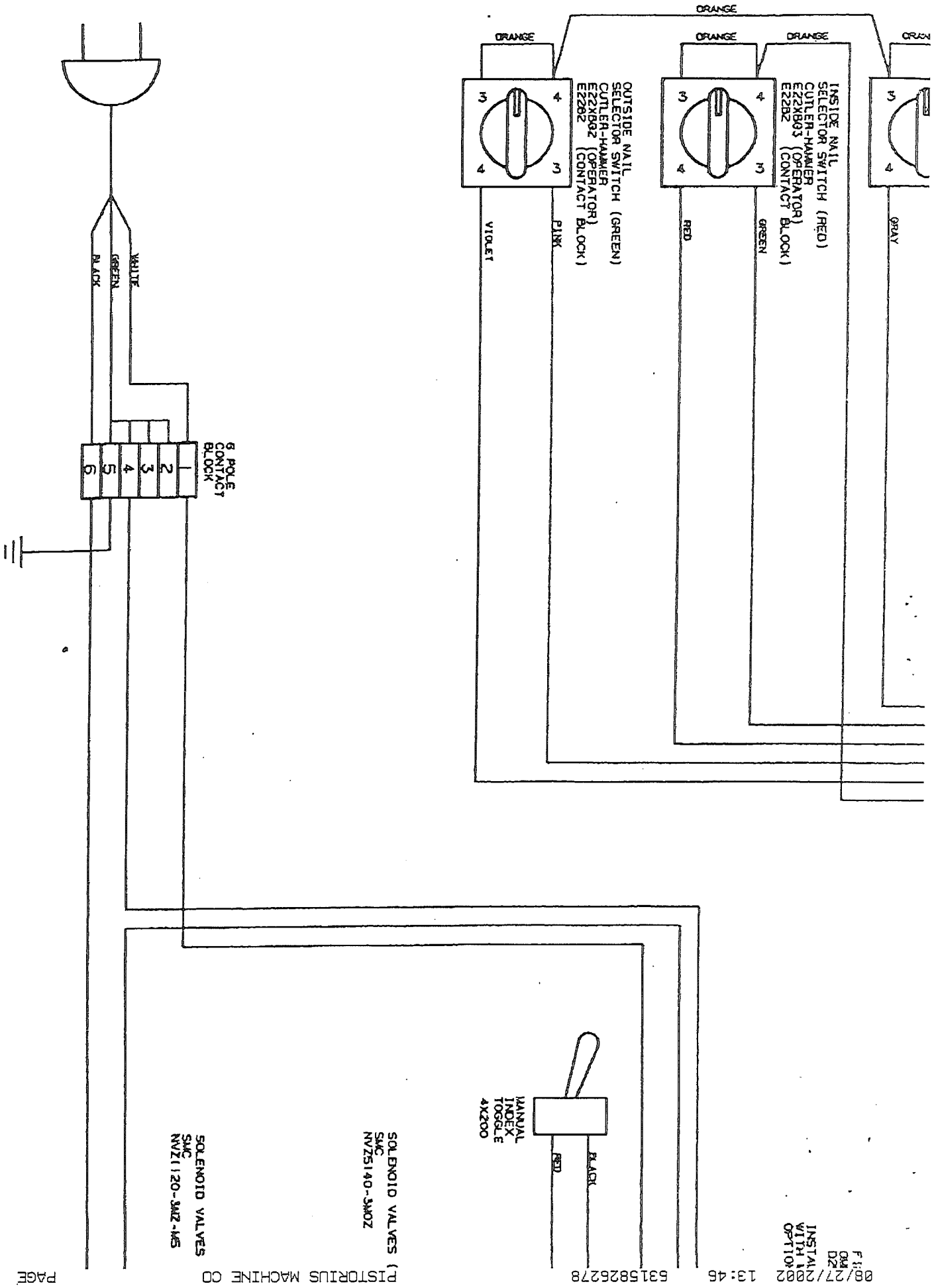

08/27/2002  
13:46  
INSTALLED WITH 10/09/11

6315826278

PISTORIUS MACHINE CD  
SOLENOID VALVES  
SMC  
NVZ1120-3M2-1A5

SOLENOID VALVES  
SMC  
NVZ1120-3M2-1A5